



RAWLPLUG®

Bonded Anchors & Mechanical Anchors

Trust & Innovation

● **1887- 1897**
RAWLINGS BROTHERS started out in London as a small firm of plumbers

● **1912**
RAWLPLUG®
Trademark registration

● **1919**
Rawlings Brothers changed company name to THE RAWLPLUG COMPANY LTD

● **1934**
Invention of the first ever mechanical anchor - RAWLBOLT®

1980's ●
Extension of the offer of Safety Plus and R-HPT mechanical anchors

● **1998** ●
RAWLPLUG became first UK manufacturer with ETA

2007 ●
Rawlplug Cartridge Free System

● **2002**
Stapling Tacking and Gluing

2009 ●
Introduction of a new line of XPT and HPT mechanical anchors / Direct Fastening Systems

1887

1912-'20

'20-'50

'50-'80

'80-'07

'09-'14

● **1911**
THE WORLD'S FIRST EXPANSION PLUG
Patent filed by Rawlings Brothers

● **1910**
JOHN RAWLINGS invented the world's first expansion plug

● **1930**
RAWLHAMMER
The world's first patented hammerdrill

● **1969**
First production of expansion plastic plugs in GLASGOW factory

● **1993** ●
First hammer-in fixing in Central Europe

● **2005**
Uno® Plug no. 1 in UK

● **2004**
Debut on Warsaw Stock Exchange



● 2012

Inauguration of Sustainable Rawplug Policy

● 2013

R-TFIX facade fixings used in energy-saving building industry/Power Tool Accessories

● 2014

Line of products for Passive Fire Protection Systems

● 2018

R-KER II Bonded Anchor, Hybrid Resin

● RAWPLUG Academy

Expand your knowledge and improve professional skills

● 2011

FF1 frame fixing

● 2016

POS Point of sale exposition system, which sells itself

● 2017

BIM Building Information Modeling

R-LX Versatile range with undisputable performance

● 2019

Celebrating 100 years! Anniversary



- Since 1911, when John Rawlings invented and filed an application to patent the world's first wall plug, the history of fixings has been inextricably linked with the RAWLPLUG® brand. Following the tremendous success of this revolutionary product in Europe, the RAWLPLUG company was founded in 1919 and quickly became renowned across the world for its innovative and reliable fixings.

Over the years, a small family company became an international organisation whose power is reflected in **13 companies** on four continents, over **1.900 employees** and almost **30.000 lines**, making up our diverse range of products. The Group's present-day know-how is a synergy of knowledge and experience based on the best practices of its subsidiaries whose main activity is developing innovative solutions in the field of fixing technologies, including their **design, production and distribution**.

Since it was founded, Rawplug has placed great emphasis on the **quality and innovation** of its products, developing research centres in Glasgow, Wroclaw and Lancut. R&D teams consisting of experienced engineers, in the quest to find innovative solutions, design products intended for a wide range of substrates and applications. Pioneering Rawplug solutions, imitated all over the world, have been defining the direction for the entire fixings industry for over 100 years.

- Nowadays Rawplug® products are used in construction, automotive, machine and electro-machine, mining, shipyard, road, timber and power industries, including around 30.000 product listings divided into 3 key groups:

Fixings & Anchors

Thermal insulation fixings for facades and roofs, self-drilling screws, lightweight & domestic fixings, frame fixings, medium & heavy-duty anchors, resin-bonded anchors and many others.

Fasteners

DIN bolts, nuts & washers, special bolts and many others (including bespoke solutions).

Tools

Hand & power tools, power tool accessories (drills, saws, chisels, etc.) and direct fastening systems.

Today Rawplug continues in its fine tradition of innovation through constant research and development of technologies and processes that minimise the company's impact on the natural environment, making sustainable development one of the pillars of its existence.

Sustainable Rawplug:

- employs a strategy of successful management and ethical business practices;
- builds long-lasting relationships based on common respect and trust with customers, suppliers and business partners thanks to an effectively designed and operated supply chain;
- cares for its employees and provides help and support to develop local communities;
- is concerned for the natural environment, focusing on areas involving production processes, employee education and cooperation with experts in the field of waste management.

Thanks to its constant emphasis on innovative solutions and customer care together with keen concern over sustainable development and environmental issues, RAWLPLUG® products continue to be acknowledged around the globe making them a world-class, first choice for the fixings industry.

Sustainable **RAWLPLUG®**

Rawlplug delivers professional and highly specialised fixing solutions, fasteners and tools supported by technical help on every level of project implementation and extensive training.

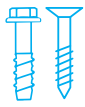

PRODUCTS, YOU CAN TRUST

Rawlplug offers a comprehensive range of reliable and innovative products that you can trust.

Our product portfolio accounts for more than 30,000 products used in the vast area of construction, starting from roof work, timber structures and gardening, including joinery, gates and fencing, facades, process installations, roads and bridges, steel, concrete and civil engineering structures, down to interior finishing and tools.

There are 10 product categories in our offer:

- Bonded and Mechanical Anchors,
- Lightweight Fixings,
- Facade Insulation and Roofing Insulation Fixings,
- Passive Fire Protection System,
- Foams and Sealants,
- Fasteners,
- Direct and Manual Fastening Systems,
- Power Tools Accessories.



TRAINING PORTFOLIO FOR YOUR PROFESSIONAL DEVELOPMENT

To meet our customers' expectations, in parallel to our products and services, we offer a range of training courses, which are aimed at both enhancing our customers skills and supporting their projects.

We are currently developing Rawlplug Academy, an e-learning platform combined with an innovative Rawlplug development scheme, which is dedicated to our clients, namely engineers, designers, contractors and distributors. Thanks to Rawlplug Academy, our partners will gain access to an integrated e-learning package and other forms of on-line training as a way to develop their know-how and skills in using Rawlplug's fixings and tools.

- Training courses,
- Workshops,
- Seminars,
- Video tutorials,
- Animations,
- Presentations,
- Webinars,
- Online courses coming soon.



SERVICES, THAT WILL MAKE YOUR JOB EASIER

Not only does Rawlplug deliver a comprehensive selection of products, but they come along with a complementary portfolio of services. These are dedicated to engineers and designers as well as to contractors and sales people.

The range and the format of the services we offer have been designed with reference to customers' actual needs that have been observed over the years as well as our mutually shared experiences from every project implementation stage, from designing down to operation. The wide selection of technical services is complemented by our POS system, which can be adapted to any space and specificity of sales points.

- We know that the success of every construction project is based on an outstanding design. This is why, engineers and designers may count on our support at every stage of their design process. They are welcome to use the following original tools:

EasyFix Software, an application intended for calculation and designing of fixings and BIM, an on-line tool enabling you to import anchors into your original designs,

- Technical Library,
- Product Selector,
- Site-testing,
- POS – Product display system.



Rawlplug® Products

BONDED ANCHORS

- **Injection Cartridges Systems**
 - Polyester Resins
 - Epoxy Resins
 - Vinylester Resins
 - **Hybrid Resins**
- **CFS+ Cartridge Free System**
 - Vinylester Resins CFS+
 - Polyester Resins CFS+
- **Capsules**
 - Hammer-In Vinylester Capsule
 - Spin-In Vinylester Capsule
- **Bonded Anchor Accessories**



MECHANICAL ANCHORS

- Heavy Duty Expansion Anchors
- Shield Anchors
- Throughbolts
- Drop-in Anchors
- Concrete Screw Bolts
- Mechanical Anchors Accessories

LIGHTWEIGHT FIXINGS

- Frame Fixings
- Lightweight Metal Fixings
- Hammer Fixings
- Plastic Expansion Plugs
- Plasterboard Fixings
- Special Fixings



FAÇADE INSULATION FIXINGS

- Screw-in Façade Fixings
- Hammer-in Façade Fixings
- Washers
- Façade Insulation Accessories

ROOFING INSULATION FIXINGS

- Telescopic Sleeves
- Roofing Screws
Screws for Concrete
Screws for Steel
- Roofing Washers



PASSIVE FIRE PROTECTION SYSTEM, FOAMS, SEALANTS & ADHESIVES



- Fire Resistant Sealants
- Fire Resistant Mortars
- Firestop Board
- Firestop Wrap
- Foams
Gun Foams
Handheld Foams
Polyurethane Foam Mortars and Adhesives
Fire Resistant Foams
Foams Accessories
- Sealants
Silicones
Roof Rubber Sealants
Acrylics
Sealants & Adhesives

DIRECT AND MANUAL FASTENING SYSTEMS

- Gas Actuated Products
- Pneumatic Products
- Powder Actuated products
- R-RAWL-RB39 Rebar Tier
- Stapling
Professional Line 140
Universal Line 53
Yellow Line 13
Cable Line 36
- Hot Melt Glue Guns
- Glue Sticks



POWER TOOL ACCESSORIES

- Drill Bits and Chisels
- Bits, Sockets and Adapters
- Sawing Accessories
- Diamond Discs
- Angle Grinder Cutting and Grinding Wheels
- Other Accessories



Services

Our entire team is composed of actual experts in the field of fixing solutions. They are industry professionals with many years of experience in the vast area of construction engineering who have spent their whole professional life in close proximity of clients, never waiving any challenge at hand. The close collaboration and experience exchange between designers, contractors, sales-people and the international Rawlplug team turn the solutions we propose into genuine advisory. What's more - all services offered by Rawlplug are free of charge.

Design tools
BIM
EASYFIX



Technical library
and product
selector



Technical
assistance



Tools for designers

Our portfolio comprises a set of complementary services and tools matching our products that, on the one hand, will make it easier for you to choose suitable fixing solution and design them correctly, and on the other hand, provide you with the information you will find indispensable for the future use. You are welcome to use:

EasyFix

Our original application dedicated to engineers and designers. This simple, yet multifunctional tool enables you to run calculations and develop designs using Rawlplug fixings. EasyFix is a guarantee of reliability and safety, since both the program itself and the calculations it delivers conform to the standards defined in European Technical Approval Guidelines (ETAG).

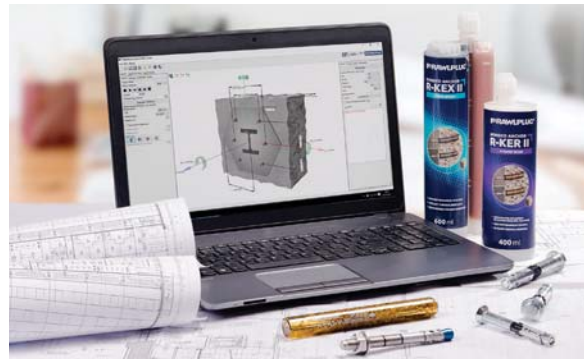

ON-LINE APPLICATION



An on-line application containing a comprehensive portfolio of models, plan views and technical drawings of Rawlplug fixings along with their full technical documentation. It enables you to use all of them in some of the most popular BIM/CAD environment software packages.

PRODUCT SELECTOR

Designed to make the choice of products matching your design's requirements easier and quicker. It is here that you can quickly view the full portfolio of criteria - from the type of substrate, a recommended application, approvals and certificates, materials and coatings, environmental conditions to an indication that a product is new in our offer. The presentation of each product includes a set of photos, drawings, technical models, video tutorials, data sheets, approvals and so on.

Fixings & Fasteners Selector

Advanced Product Selector makes your choice easier and faster

Product categories	Base materials	Applications	Approvals & Certificates	Materials / Coatings	Environmental conditions	New in offer
Bonded anchors	Mechanical Anchors	Lightweight Fixings	Facade Insulation Fixings	Roofing Insulation Fixings	Passive Fire Protection System	



TECHNICAL LIBRARY

Contains technical documentation of products divided into as many as 15 categories. All you need to do is enter the name of the product and a list of all technical documents available in our library will appear in the search results.

> Technical Assistance

Our team is ready to deliver comprehensive technical assistance. The range of services comprises:

- **technical advisory,**
- **site testing,**
- **assistance in designing of fixings,**
- **technical FAQ.**

TECHNICAL ADVISORY

Our clients are offered the support of an engineering team from the Technical Department. They are ready to answer all your questions pertaining to the design of fixings, the range of their applications, the installation process or the service of Rawlplug's products. You only need to fill in the Technical Request Form on www.rawlplug.com.



SITE TESTING

While running site tests, we make use of our signature standard, designed with reference to the requirements of British Standard BS:8539 as well as guidelines of the British Construction Fixings Association (CFA). It was our team of experts, being members of the Technical Committee, who developed these principles and who provide testing oversight.

ASSISTANCE IN DESIGNING OF FIXINGS

We offer support for the extensive range of fixing design activities. Our team of engineers from the Technical Department is at your disposal. They will answer all your questions related to the design of fixings and their recommended applications. We encourage you to contact our experts on www.rawlplug.com.



TECHNICAL FAQ

Based on our experience to date, and thanks to the regular close relationship with our customers and understanding of the challenges they face on a daily basis, we have developed a list of the most typical issues and areas in the format of easily searchable questions and intuitive answers. The list of the most frequently asked questions is available on www.rawlplug.com.

Rawlplug POS System

Presentation of Rawlplug's products is based on an integrated display system operating on 3 levels:

- Point of Sale product display system
- labelling
- packaging

What we offer in this scope is innovative across the market and provides us with unquestionable competitive edge. Not only does the POS product display system ensure formal attractiveness, but primarily stands for unparalleled functionality and intuitiveness whenever Rawlplug products are to be chosen from among hundreds of other items available on store shelves. And even more importantly, it supports the consumer in making the right choice.

When designing the POS system, we were guided by principles that reflect the real needs and behaviour of customers at the point of purchase. By that means we have managed to create features that are characteristic only for the Rawlplug product display system:

colour coding, key words, installation guidelines, QR codes, standard display system, customised display system, unique packaging, environmental sustainability

COLOUR CODING

products intended for specific substrates are marked with specific colours, enabling instantaneous choice of suitable products with this criterion in mind.

KEY WORDS

in order to describe our products we have used key words that users recognise intuitively, which significantly speeds up the choice of what one truly needs.

INSTALLATION GUIDELINES

simplicity of use is crucial to contractors, and we additionally allow them to quickly read and understand instructions thanks to icons and step-by-step type presentation models



QR CODES

every product packaging features a QR code the scanning of which provides you with access to videos and animations with installation instructions.

STANDARD DISPLAY SYSTEM

we can provide you with complete display systems ready for installation at points of sale, with all the features required to enable making appropriate and quick choice of products in demand.

CUSTOMISED DISPLAY SYSTEM

we also provide you with an opportunity to develop a customised display set based on individual, specific customer requirements, which is possible thanks to the modularity of our solutions as well as their adaptability to any size and layout of a specific shop.

UNIQUE PACKAGING

for every product, we have developed attractive, ergonomic and comfortable to use unique packaging.

ENVIRONMENTAL SUSTAINABILITY

our products are manufactured using sustainable technological standards which matter greatly to environmental protection.





Inspired by
knowledge & skills

Rawlplug Academy is an innovative development project intended for our clients. It is a unique venture across the industry, dedicated to education, competence building as well as knowledge and experience sharing, designed to reflect the actual needs of engineers and designers, contractors and salespeople. What you receive is a single point of access to an integrated training package that will not only help you in everyday operations, but also assist you in the development of your specialisation.

A state-of- the art knowledge and training platform

Courses
available
online – you
study when and
where you want



Varied forms
of training



Courses
designed
in accordance
with both
business and
personal needs



4 types of training
categories:
courses that develop
products and services
competences, operating
systems skills and legally
required courses



Enhance your knowledge,
master new skills

Every course
concludes
with a test



www.rawlplugacademy.com

Under the **Rawplug Academy**, we perform three types of training activities:

- **Rawplug Academy's original training courses** devised to reflect the operating needs of our customers,
- **vocational training** courses conducted under prestigious country-specific educational programmes,
- **video tutorials** collected in a library of training videos and animations.

ORIGINAL TRAINING COURSES

The Rawplug Academy original training scheme comprises series of specialised courses, soon to be available to our on-line clients as well.



RAWPLUG® Academy



VOCATIONAL TRAINING COURSES

Being a professional partner who provides clients with integrated education and knowledge sharing services, we extend our Rawplug Academy related activities by participating in development programmes whose purpose is to expand specialised qualifications and improve field-specific competencies. This is why our experts have become personally engaged in developing training courses and workshops under the Continuing Professional Development scheme and BS:8539.

CPD Seminars

Specialists representing the Rawplug team take part in various initiatives, tutoring industry-specific seminars, co-moderating major conferences and events relevant to the sector as well as organising practical workshops aimed at improving participants' competencies in terms of professional choice and applications of fixing and fastening solutions. In this milieu, we collaborate with such parties as the Institution of Civil Engineers (ICE) and the Institution of Structural Engineers (IStructE). Each person taking part in the CPD seminars run by experts from Rawplug Ltd. acquires qualifications documented with a certificate that proves to be a significant add-on to a professional portfolio.

BS:8539 COURSES

Rawplug Ltd. is a certified member of the Construction Fixings Association (CFA). The membership is indeed a prestigious achievement, but it also an obligation. That is why, we organise and conduct seminars and workshops in line with British Standard BS:8539. This means that as we deliver training we always rely on the best available practices. Participation in BS:8539 courses is certified, which enables the participant to formally confirm the qualifications and competencies thus acquired.

VIDEO TUTORIALS

Based on many years of observations of the processes and activities connected with everyday operations performed by our clients, we have developed scripts for video tutorials. How do they work? We teach you how to choose the best fixing solutions. We demonstrate where and under what circumstances they should be applied. We present how to use them under real-life conditions. And the entire content is delivered in a simple, intuitive and comprehensible manner. You are welcome to use the library of Rawplug's video tutorials.



Rawlplug®
is an unsung hero
of many construction
projects all over
the world.

Burj Khalifa Tower*
United Arab Emirates, Dubai



Admiring spectacular structures known all over the world, we are delighted with their beauty, splendour and functionality. And we are delighted that we can offer you the highest reliability, durability and aesthetics thanks to the application of Rawlplug® products. There are millions of fasteners and anchors, the appropriate selection of which allows you to admire the beauty, and to ensure the safe use safely use, of the facilities that are visited by thousands of people every day.

Wembley Stadium*
United Kingdom, London



Curiosity rover*
Solar System, Mars



By NASA/JPL-Caltech/MSSS. Derivative work including grading, distortion correction, minor local adjustment and rendering from TIFF file: Julian Herzog (<http://photojournal.jpl.nasa.gov/PIA15883.jpg>) [public domain], via Wikimedia Commons

Metro Bucharest*
Romania, Bucharest



Delhi Metro
India, New Delhi



Source: https://en.wikipedia.org/wiki/State_Courts_of_Singapore

* Names of the buildings or engineering constructions may be registered as trademarks in the name of third parties. Rawlplug is not an owner of said trademarks and claims no rights thereon.

➤ We are proud that our products facilitate your work and increase comfort, effectiveness and quality of work,

meeting even the most specific and ambitious needs of our Customers. And we want to share this pride with you. Every year, our portfolio is extended with new investments that allow us to carry out the mission of Rawlplug, i.e. to provide the state-of-the-art reliable solutions.

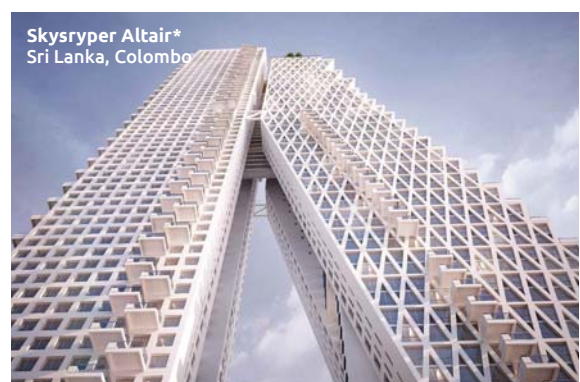
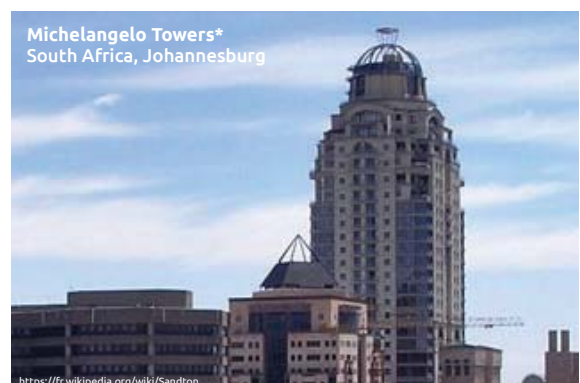

Contents

OVERVIEW OF OUR RANGE					18
CORROSION PROTECTION					30
RESEARCH AND DEVELOPMENT					44
RAWLPLUG SUPPORT					48
BASICS OF ANCHORING					53
BONDED ANCHORS:					68
R-KEX II PURE EPOXY RESIN					71
R-KER II HYBRID RESIN					94
R-KER STYRENE-FREE VINYLESTER RESIN					124
R-KEM II STYRENE-FREE POLYESTER RESIN					147
R-KF2 POLYESTER RESIN					159
RV200 STYRENE-FREE VINYLESTER RESIN FOIL					165
RM50 STYRENE-FREE POLYESTER RESIN FOIL					187
RP30 POLYESTER RESIN FOIL					198
R-CAS-V VINYLESTER RESIN SPIN-IN CAPSULE					205
R-HAC-V VINYLESTER RESIN HAMMER-IN CAPSULE					209
ACCESSORIES:					217

Contents

MECHANICAL ANCHORS:				242
R-HPTIIA4 STAINLESS STEEL THROUGH BOLT				245
R-HPTIIFZ THROUGH BOLT - ZINC FLAKE				250
R-XPTIIA4 STAINLESS STEEL THROUGH BOLT				255
R-XPT THROUGH BOLT - ZINC PLATED				259
R-XPT-HD THROUGH BOLT - HOT DIP GALVANIZED				261
R-LX CONCRETE SCREW ANCHOR				268
RAWLBOLT ALL-PURPOSE EXPANSION ANCHOR				283
SAFETYPLUSII HEAVY-DUTY EXPANSION ANCHOR				308
SAFETYPLUS HEAVY-DUTY EXPANSION ANCHOR				312
R-DCA-A4 STAINLESS STEEL WEDGE ANCHOR				317
R-DCA & R-DCL PLAIN & LIPPED WEDGE ANCHORS				320
R-DCA-ST-PLUS & R-DCA-ST WEDGE ANCHOR SETTING TOOLS				323
ACCESSORIES:				326
DRILL BITS				330
PACKAGING SYSTEM				354

Overview of our range - Bonded anchor selector









BONDED ANCHOR SYSTEM:		R-KEX II with threaded rods	R-KEX II with ITS	R-KEX II with rebar as an anchor	R-KEX II with post-installed rebar	R-KER II with threaded rods	R-KER II with ITS	R-KER II with rebar as an anchor	R-KER II S with post-installed rebar	R-KER with threaded rods	R-KER with ITS
RESIN		PURE EPOXY				HYBRID				VINYLESTER	
ANCHOR MATERIAL	5.8 STEEL CLASS, ZINC PLATED	<input checked="" type="checkbox"/>	-	-	-	<input checked="" type="checkbox"/>	-	-	-	<input checked="" type="checkbox"/>	-
	8.8 STEEL CLASS, ZINC PLATED	<input checked="" type="checkbox"/>	-	-	-	<input checked="" type="checkbox"/>	-	-	-	<input checked="" type="checkbox"/>	-
	STAINLESS STEEL	<input checked="" type="checkbox"/>	-	-	-	<input checked="" type="checkbox"/>	-	-	-	<input checked="" type="checkbox"/>	-
	REBAR	-	-	<input checked="" type="checkbox"/>	<input checked="" type="checkbox"/>	-	-	<input checked="" type="checkbox"/>	<input checked="" type="checkbox"/>	-	-
	R-ITS	-	<input checked="" type="checkbox"/>	-	-	-	<input checked="" type="checkbox"/>	-	-	-	<input checked="" type="checkbox"/>
SUBSTRATES	CONCRETE	<input checked="" type="checkbox"/>	<input checked="" type="checkbox"/>	<input checked="" type="checkbox"/>	<input checked="" type="checkbox"/>	<input checked="" type="checkbox"/>	<input checked="" type="checkbox"/>	<input checked="" type="checkbox"/>	<input checked="" type="checkbox"/>	<input checked="" type="checkbox"/>	<input checked="" type="checkbox"/>
	CRACKED CONCRETE	<input checked="" type="checkbox"/>	-	<input checked="" type="checkbox"/>	<input checked="" type="checkbox"/>	<input checked="" type="checkbox"/>	<input checked="" type="checkbox"/>	<input checked="" type="checkbox"/>	<input checked="" type="checkbox"/>	<input checked="" type="checkbox"/>	-
	SILICATE BRICK	-	-	-	-	-	-	-	-	-	-
	SOLID BRICK	-	-	-	-	-	-	-	-	-	-
	HOLLOW BRICK	-	-	-	-	-	-	-	-	-	-
	LIGHTWEIGHT CONCRETE BLOCKS	-	-	-	-	-	-	-	-	-	-
	BETON KOMÓRKOWY	-	-	-	-	-	-	-	-	-	-
APPROVALS		<input checked="" type="checkbox"/> ETA Option 1	<input checked="" type="checkbox"/> ETA Option 7	<input checked="" type="checkbox"/> ETA Option 7	<input checked="" type="checkbox"/> ETA Option 7	<input checked="" type="checkbox"/> ETA Option 1	<input checked="" type="checkbox"/> ETA Option 7	<input checked="" type="checkbox"/> ETA Option 7	<input checked="" type="checkbox"/> ETA Option 7	<input checked="" type="checkbox"/> ETA Option 1	<input checked="" type="checkbox"/> ETA Option 7
	IBDIM	<input checked="" type="checkbox"/>	<input checked="" type="checkbox"/>	<input checked="" type="checkbox"/>	<input checked="" type="checkbox"/>	<input checked="" type="checkbox"/>	<input checked="" type="checkbox"/>	<input checked="" type="checkbox"/>	<input checked="" type="checkbox"/>	<input checked="" type="checkbox"/>	<input checked="" type="checkbox"/>
DESIGN TENSION LOADS IN kN	[kN]	N _{Rd}	N _{Rd}	N _{Rd}	N _{Rd}	N _{Rd}	N _{Rd}	N _{Rd}	N _{Rd}	N _{Rd}	N _{Rd}
	10	M8	M6	Ø8	Ø8	M8	M6	Ø8	Ø8	M8	M6
	20										
	30										
	40		M16				M 16				M16
	50										
	60										
	70										
	80										
	90										
	100										
	120									M30	
	140										
	160										
	180										
	200										
	220										
240											
260											
280											
300	M30		Ø32		M 30		Ø32				
350											
400									Ø40		
500				Ø40							

Overview of our range - Mechanical anchor selector



MECHANICAL ANCHORS:		R-HPTIIA4	R-HPTIIF	R-XPTIIA4	R-XPT	R-XPT-HD					
ANCHOR MATERIAL	ZINC PLATED STEEL	-	-	-	<input checked="" type="checkbox"/>	-					
	ZINC FLAKED STEEL	-	<input checked="" type="checkbox"/>	-	-	-					
	HOT DIP GALVANIZED STEEL	-	-	-	-	<input checked="" type="checkbox"/>					
	STAINLESS STEEL	<input checked="" type="checkbox"/>	-	<input checked="" type="checkbox"/>	-	-					
SUBSTRATES	CONCRETE 	<input checked="" type="checkbox"/>	<input checked="" type="checkbox"/>	<input checked="" type="checkbox"/>	<input checked="" type="checkbox"/>	<input checked="" type="checkbox"/>					
	CRACKED CONCRETE 	<input checked="" type="checkbox"/>	<input checked="" type="checkbox"/>	-	-	-					
	REINFORCED CONCRETE 	<input checked="" type="checkbox"/>	<input checked="" type="checkbox"/>	<input checked="" type="checkbox"/>	<input checked="" type="checkbox"/>	<input checked="" type="checkbox"/>					
	STONE 	<input checked="" type="checkbox"/>	<input checked="" type="checkbox"/>	<input checked="" type="checkbox"/>	<input checked="" type="checkbox"/>	<input checked="" type="checkbox"/>					
	SOLID BRICK 	-	-	-	-	-					
	SILIKATE HOLLOW BRICK 	-	-	-	-	-					
	HOLLOW CORE SLAB 	-	-	-	-	-					
APPROVALS		<input checked="" type="checkbox"/> ETA Option 1	<input checked="" type="checkbox"/> ETA Option 1	<input checked="" type="checkbox"/> ETA Option 7	<input checked="" type="checkbox"/> ETA Option 7	-					
		<input checked="" type="checkbox"/>	<input checked="" type="checkbox"/>	-	<input checked="" type="checkbox"/>	-					
		<input checked="" type="checkbox"/> C1	<input checked="" type="checkbox"/> C1, C2	-	-	-					
		-	-	-	<input checked="" type="checkbox"/> for M6 and M24	<input checked="" type="checkbox"/>					
DESIGN TENSION AND SHEAR LOADS IN kN	[kN]	N _{Rd}	V _{Rd}	N _{Rd}	V _{Rd}	N _{Rd}	V _{Rd}	N _{Rd}	V _{Rd}	N _{Rd}	V _{Rd}
	5	M8	M8	M8	M8	M8	M8	M6	M6	M6	M6
	10										
	15									M24	
	20							M24			
	25	M16				M16					
	30			M20							M24
	35		M16				M16				
	40										
	45										
	50								M24		
	60				M20						
	70										
80											
90											
100											

Overview of our range - Mechanical anchor selector

RAWLBOLT		SAFETY PLUS II		SAFETY PLUS		R-DCA		R-DCL		R-DCA-A4		R-LX	
													
<input checked="" type="checkbox"/>	<input checked="" type="checkbox"/>	<input checked="" type="checkbox"/>	<input checked="" type="checkbox"/>	<input checked="" type="checkbox"/>	<input checked="" type="checkbox"/>	<input checked="" type="checkbox"/>	<input checked="" type="checkbox"/>	<input checked="" type="checkbox"/>	<input checked="" type="checkbox"/>	-	<input checked="" type="checkbox"/>	<input checked="" type="checkbox"/>	<input checked="" type="checkbox"/>
-	<input checked="" type="checkbox"/>	<input checked="" type="checkbox"/>	-	-	-	-	-	-	-	-	-	<input checked="" type="checkbox"/>	<input checked="" type="checkbox"/>
-	-	-	-	-	-	-	-	-	-	-	-	-	-
-	-	-	-	-	-	-	-	-	-	<input checked="" type="checkbox"/>	-	-	-
<input checked="" type="checkbox"/>	<input checked="" type="checkbox"/>	<input checked="" type="checkbox"/>	<input checked="" type="checkbox"/>	<input checked="" type="checkbox"/>	<input checked="" type="checkbox"/>	<input checked="" type="checkbox"/>	<input checked="" type="checkbox"/>	<input checked="" type="checkbox"/>	<input checked="" type="checkbox"/>	<input checked="" type="checkbox"/>	<input checked="" type="checkbox"/>	<input checked="" type="checkbox"/>	<input checked="" type="checkbox"/>
<input checked="" type="checkbox"/>	<input checked="" type="checkbox"/>	-	<input checked="" type="checkbox"/>	<input checked="" type="checkbox"/>	<input checked="" type="checkbox"/>	<input checked="" type="checkbox"/>	<input checked="" type="checkbox"/>	<input checked="" type="checkbox"/>	<input checked="" type="checkbox"/>	<input checked="" type="checkbox"/>	<input checked="" type="checkbox"/>	<input checked="" type="checkbox"/>	<input checked="" type="checkbox"/>
<input checked="" type="checkbox"/>	<input checked="" type="checkbox"/>	<input checked="" type="checkbox"/>	<input checked="" type="checkbox"/>	<input checked="" type="checkbox"/>	<input checked="" type="checkbox"/>	<input checked="" type="checkbox"/>	<input checked="" type="checkbox"/>	<input checked="" type="checkbox"/>	<input checked="" type="checkbox"/>	<input checked="" type="checkbox"/>	<input checked="" type="checkbox"/>	<input checked="" type="checkbox"/>	<input checked="" type="checkbox"/>
<input checked="" type="checkbox"/>	-	-	-	-	-	-	-	-	-	-	-	-	-
<input checked="" type="checkbox"/>	-	-	-	-	-	-	-	-	-	-	-	-	-
<input checked="" type="checkbox"/> AT-15-7280/2014	-	-	-	-	-	-	-	-	-	-	-	<input checked="" type="checkbox"/>	<input checked="" type="checkbox"/>
<input checked="" type="checkbox"/> ETA Option 1	<input checked="" type="checkbox"/> ETA Option 1	<input checked="" type="checkbox"/> ETA Option 7	<input checked="" type="checkbox"/> ETA Option 1, part 6	<input checked="" type="checkbox"/> ETA Option 1, part 6	<input checked="" type="checkbox"/> ETA Option 1, part 6	<input checked="" type="checkbox"/> ETA Option 1, part 6	<input checked="" type="checkbox"/> ETA Option 1	<input checked="" type="checkbox"/> ETA Option 1	<input checked="" type="checkbox"/> ETA Option 1	<input checked="" type="checkbox"/> ETA Option 1, part 6	<input checked="" type="checkbox"/> ETA Option 1, part 6	<input checked="" type="checkbox"/> ETA Option 1	<input checked="" type="checkbox"/> ETA Option 1
<input checked="" type="checkbox"/>	<input checked="" type="checkbox"/>	-	<input checked="" type="checkbox"/>	<input checked="" type="checkbox"/>	<input checked="" type="checkbox"/>	<input checked="" type="checkbox"/>	<input checked="" type="checkbox"/>	<input checked="" type="checkbox"/>	<input checked="" type="checkbox"/>	<input checked="" type="checkbox"/>	<input checked="" type="checkbox"/>	<input checked="" type="checkbox"/>	<input checked="" type="checkbox"/>
-	<input checked="" type="checkbox"/> C1, C2	-	-	-	-	-	-	-	-	-	-	<input checked="" type="checkbox"/> C1, C2	<input checked="" type="checkbox"/> C1, C2
<input checked="" type="checkbox"/>	-	-	-	-	-	-	-	-	-	-	-	-	-
N_{Rd}	V_{Rd}	N_{Rd}	V_{Rd}	N_{Rd}	V_{Rd}	N_{Rd}	V_{Rd}	N_{Rd}	V_{Rd}	N_{Rd}	V_{Rd}	N_{Rd}	V_{Rd}
M6	M8	M8	M8	M8	M8	M6	M6	M6	M6	M6-M20	M6-M20	5	5
						M20	M20	M20	M20				
				M20									
M20		M16			M20							14	
	M24												14
		M16											

Development, Testing, Approvals, Quality Assurance & Technical Support

RAWLPLUG's® newest additions to the bonded, mechanical and plastic anchor ranges are developed and tested in our comprehensively equipped research and development centres in Glasgow (Scotland) and Wroclaw/Lancut (Poland).

The resultant technical data has been approved in various European Member States and by the following organisations: BBA (UK), CSTB (France), DIBT (Germany), FM Global (USA), SINTEF (Norway) and ITB (Poland).



Our extensive set of European Technical Approvals and Assessments (ETAs) cover our bonded anchors (used with studs, rebar and/or internally threaded sockets) for use in cracked and non-cracked concrete, as well as masonry and hollow substrates. (See individual products for approved uses.) Meanwhile our mechanical anchor range also holds several ETAs indicating their suitability for applications in cracked and non-cracked concrete, stone and brick.

Furthermore, we are proud that our production is subject to the control of a quality assurance system approved by the following bodies: BSI (UK), TÜV Rheinland (Germany), AFNOR (France) and ITB (Poland).

Our team of technical consultants are at your disposal for advice, seminars and on-site installer training to support our extensive range of fasteners and fixings. On-site product testing can also be arranged.

Ultimately, the RAWLPLUG® team will help you to ensure that you choose the best solution for your application.

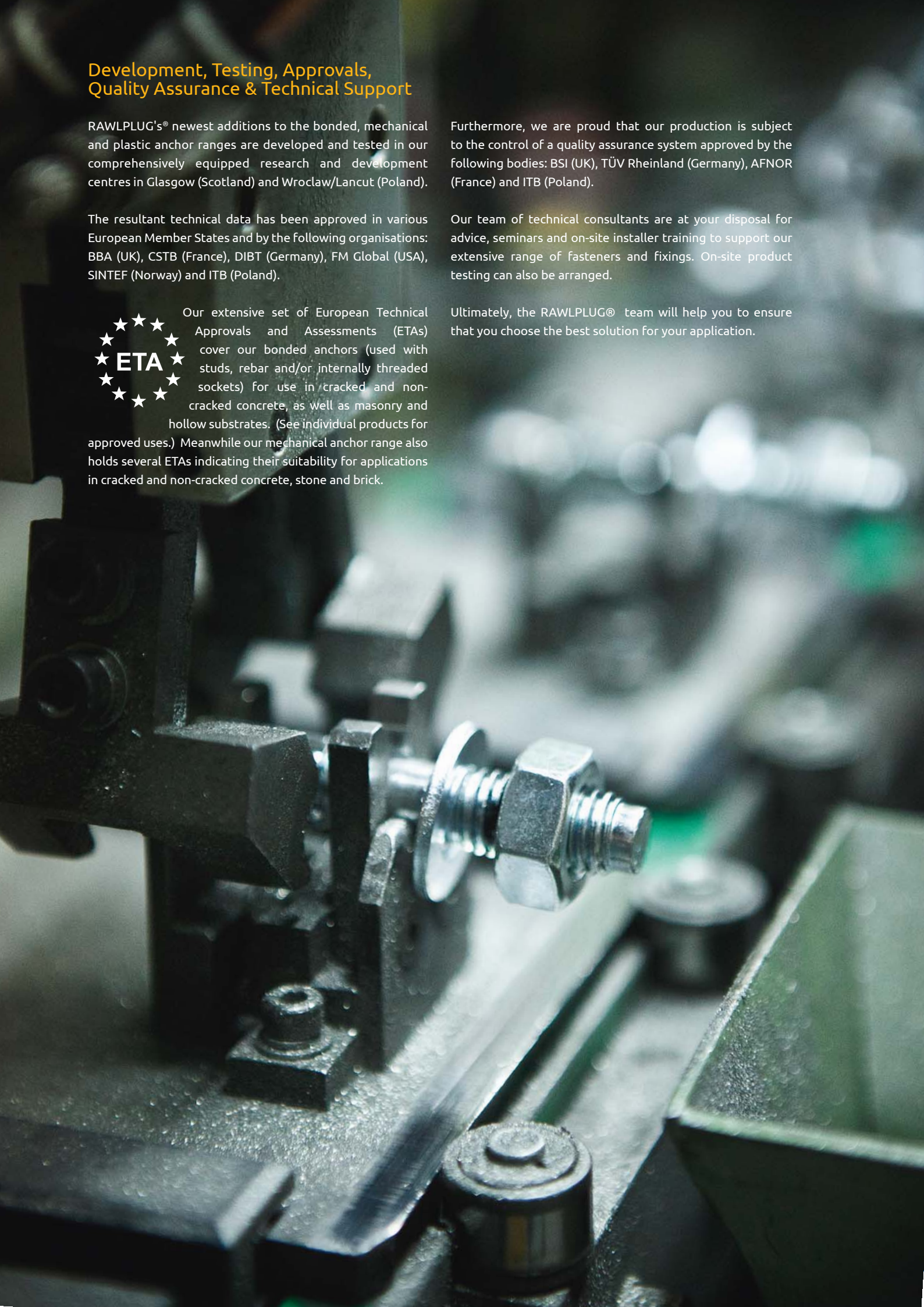

		MECHANICAL ANCHORS					BONDED ANCHORS						
		THROUGHBOLTS	SHIELD ANCHORS	HEAVY-DUTY EXPANSION ANCHORS	WEDGE ANCHORS	SCREW ANCHOR	POLYESTER RESINS	POLYESTER RESINS	VINYLESTER RESINS	HYBRID RESINS	PURE-EPOXY RESINS	SPIN-IN CAPSULES	HAMMER-IN CAPSULES
APPLICATIONS - CONSTRUCTION	BALUSTRADING		<input checked="" type="checkbox"/>	<input checked="" type="checkbox"/>		<input checked="" type="checkbox"/>	<input checked="" type="checkbox"/>	<input checked="" type="checkbox"/>	<input checked="" type="checkbox"/>	<input checked="" type="checkbox"/>	<input checked="" type="checkbox"/>	<input checked="" type="checkbox"/>	<input checked="" type="checkbox"/>
	BARRIERS		<input checked="" type="checkbox"/>				<input checked="" type="checkbox"/>	<input checked="" type="checkbox"/>	<input checked="" type="checkbox"/>	<input checked="" type="checkbox"/>	<input checked="" type="checkbox"/>	<input checked="" type="checkbox"/>	<input checked="" type="checkbox"/>
	CABLE TRAYS		<input checked="" type="checkbox"/>		<input checked="" type="checkbox"/>		<input checked="" type="checkbox"/>	<input checked="" type="checkbox"/>	<input checked="" type="checkbox"/>				
	CLADDING		<input checked="" type="checkbox"/>		<input checked="" type="checkbox"/>	<input checked="" type="checkbox"/>	<input checked="" type="checkbox"/>	<input checked="" type="checkbox"/>	<input checked="" type="checkbox"/>	<input checked="" type="checkbox"/>	<input checked="" type="checkbox"/>	<input checked="" type="checkbox"/>	<input checked="" type="checkbox"/>
	CONDUITS		<input checked="" type="checkbox"/>		<input checked="" type="checkbox"/>		<input checked="" type="checkbox"/>	<input checked="" type="checkbox"/>	<input checked="" type="checkbox"/>				
	CURTAIN WALLING		<input checked="" type="checkbox"/>			<input checked="" type="checkbox"/>	<input checked="" type="checkbox"/>	<input checked="" type="checkbox"/>	<input checked="" type="checkbox"/>	<input checked="" type="checkbox"/>	<input checked="" type="checkbox"/>		
	DOORS & WINDOWS					<input checked="" type="checkbox"/>	<input checked="" type="checkbox"/>	<input checked="" type="checkbox"/>				<input checked="" type="checkbox"/>	<input checked="" type="checkbox"/>
	FACADES		<input checked="" type="checkbox"/>						Copy eco <input checked="" type="checkbox"/>				
	FENCING & GATES		<input checked="" type="checkbox"/>	<input checked="" type="checkbox"/>			<input checked="" type="checkbox"/>	<input checked="" type="checkbox"/>	<input checked="" type="checkbox"/>			<input checked="" type="checkbox"/>	<input checked="" type="checkbox"/>
	LIFTS & ESCALATORS		<input checked="" type="checkbox"/>	<input checked="" type="checkbox"/>	<input checked="" type="checkbox"/>	<input checked="" type="checkbox"/>			<input checked="" type="checkbox"/>	<input checked="" type="checkbox"/>	<input checked="" type="checkbox"/>	<input checked="" type="checkbox"/>	<input checked="" type="checkbox"/>

main application

Bonded & Mechanical Anchors

		THROUGHBOLTS	SHIELD ANCHORS	HEAVY-DUTY EXPANSION ANCHORS	WEDGE ANCHORS	SCREW ANCHOR	POLYESTER RESINS	POLYESTER RESINS	VINYLESTER RESINS	HYBRID RESINS	PURE-EPOXY RESINS	SPIN-IN CAPSULES	HAMMER-IN CAPSULES	
		MECHANICAL ANCHORS					BONDED ANCHORS							
ANCHOR TYPE:														
APPLICATIONS - CONSTRUCTION	MACHINERY	<input checked="" type="checkbox"/>	<input checked="" type="checkbox"/>	<input checked="" type="checkbox"/>				<input checked="" type="checkbox"/>	<input checked="" type="checkbox"/>	<input checked="" type="checkbox"/>	<input checked="" type="checkbox"/>	<input checked="" type="checkbox"/>	<input checked="" type="checkbox"/>	
	MASONRY SUPPORT		<input checked="" type="checkbox"/>	<input checked="" type="checkbox"/>			<input checked="" type="checkbox"/>	<input checked="" type="checkbox"/>	<input checked="" type="checkbox"/>					
	PIPEWORK	<input checked="" type="checkbox"/>	<input checked="" type="checkbox"/>		<input checked="" type="checkbox"/>		<input checked="" type="checkbox"/>	<input checked="" type="checkbox"/>	<input checked="" type="checkbox"/>					
	PLATFORMS	<input checked="" type="checkbox"/>							<input checked="" type="checkbox"/>	<input checked="" type="checkbox"/>	<input checked="" type="checkbox"/>	<input checked="" type="checkbox"/>	<input checked="" type="checkbox"/>	
	PUBLIC SEATING	<input checked="" type="checkbox"/>			<input checked="" type="checkbox"/>	<input checked="" type="checkbox"/>			<input checked="" type="checkbox"/>			<input checked="" type="checkbox"/>	<input checked="" type="checkbox"/>	
	RACKING SYSTEMS	<input checked="" type="checkbox"/>	<input checked="" type="checkbox"/>	<input checked="" type="checkbox"/>		<input checked="" type="checkbox"/>	<input checked="" type="checkbox"/>	<input checked="" type="checkbox"/>	<input checked="" type="checkbox"/>	<input checked="" type="checkbox"/>	<input checked="" type="checkbox"/>			
	RAINSCREENS	<input checked="" type="checkbox"/>							<input checked="" type="checkbox"/>					
	REBAR								<input checked="" type="checkbox"/>	<input checked="" type="checkbox"/>	<input checked="" type="checkbox"/>		<input checked="" type="checkbox"/>	
	SIGNS			<input checked="" type="checkbox"/>					<input checked="" type="checkbox"/>	<input checked="" type="checkbox"/>	<input checked="" type="checkbox"/>	<input checked="" type="checkbox"/>		
	SCAFFOLDING	<input checked="" type="checkbox"/>			<input checked="" type="checkbox"/>	<input checked="" type="checkbox"/>			<input checked="" type="checkbox"/>	<input checked="" type="checkbox"/>	<input checked="" type="checkbox"/>	<input checked="" type="checkbox"/>	<input checked="" type="checkbox"/>	

main application

All products listed in this publication are branded and distributed with RAWLPLUG® or RAWL® trademarks.

		ANCHOR TYPE:	MECHANICAL ANCHORS					BONDED ANCHORS							
			THROUGHBOLTS	SHIELD ANCHORS	HEAVY-DUTY EXPANSION ANCHORS	WEDGE ANCHORS	SCREW ANCHOR	POLYESTER RESINS	POLYESTER RESINS	VINYLESTER RESINS	HYBRID RESINS	PURE-EPOXY RESINS	SPIN-IN CAPSULES	HAMMER-IN CAPSULES	
APPLICATIONS - CONSTRUCTION	STRUCTURAL STEELWORK		<input checked="" type="checkbox"/>	<input checked="" type="checkbox"/>	<input checked="" type="checkbox"/>		<input checked="" type="checkbox"/>				<input checked="" type="checkbox"/>	<input checked="" type="checkbox"/>	<input checked="" type="checkbox"/>	<input checked="" type="checkbox"/>	
	SUSPENDED CEILINGS		<input checked="" type="checkbox"/>	<input checked="" type="checkbox"/>		<input checked="" type="checkbox"/>									
	TEMPORARY WORK					<input checked="" type="checkbox"/>	<input checked="" type="checkbox"/>			<input checked="" type="checkbox"/>	<input checked="" type="checkbox"/>	<input checked="" type="checkbox"/>	<input checked="" type="checkbox"/>	<input checked="" type="checkbox"/>	
APPLICATION - DOMESTIC	HANDRAILS		<input checked="" type="checkbox"/>				<input checked="" type="checkbox"/>	<input checked="" type="checkbox"/>	<input checked="" type="checkbox"/>	<input checked="" type="checkbox"/>			<input checked="" type="checkbox"/>	<input checked="" type="checkbox"/>	
	BATHROOM FITTINGS						<input checked="" type="checkbox"/>	<input checked="" type="checkbox"/>							
	KITCHEN UNITS						<input checked="" type="checkbox"/>	<input checked="" type="checkbox"/>	<input checked="" type="checkbox"/>						
	MIRRORS						<input checked="" type="checkbox"/>	<input checked="" type="checkbox"/>	<input checked="" type="checkbox"/>						
	AWNINGS		<input checked="" type="checkbox"/>	<input checked="" type="checkbox"/>				<input checked="" type="checkbox"/>	<input checked="" type="checkbox"/>						
	SHUTTERS		<input checked="" type="checkbox"/>	<input checked="" type="checkbox"/>	<input checked="" type="checkbox"/>			<input checked="" type="checkbox"/>	<input checked="" type="checkbox"/>						
	TV BRACKETS		<input checked="" type="checkbox"/>				<input checked="" type="checkbox"/>	<input checked="" type="checkbox"/>	<input checked="" type="checkbox"/>						

main application

Overview of our range

BONDED ANCHORS - RESIN TYPES

PURE EPOXY	HYBRID	VINYLESTER	POLYESTER STYRENE FREE
<ul style="list-style-type: none"> • Most suitable for construction, as well as for deep anchorages. • Designed for heavy-duty anchorages in cracked and non-cracked concrete. • Suitable for use in dry and wet substrates as well as holes and substrates covered with water. • Designed for deep anchorages 2,5 m 	<ul style="list-style-type: none"> • Product with wide spectrum of use in the high and medium load • Designed for deep anchorages 1,5 m • Suitable for use in cracked and non-cracked concrete. • Suitable for use in dry and wet substrates as well as holes and • Substrates covered with water. • Product with extensive certification C1, VOC, R-240 	<ul style="list-style-type: none"> • Most common product for construction. • Intended for medium and heavy-duty anchorages in cracked and non-cracked concrete. • Suitable for use in low temperatures (down to -20°C for winter option) enables use throughout the year • Suitable for use in dry and wet substrates as well as holes and substrates covered with water 	<ul style="list-style-type: none"> • The most contemporary general use bonded anchor. • Intended for medium-duty fixings in 15 types. • Low odour suitable for indoor applications. • Product with wide spectrum of use in the medium load capacity area.



BONDED ANCHORS ARE OFFERED IN A WIDE RANGE OF SYSTEMS:

GLASS CAPSULES	CARTRIDGES	FOILS
<p>Glass capsules containing both the resin and hardener, which mix and set after the stud or socket is driven in to the hole.</p>	<p>Tubular plastic cartridges containing resin. Various formats depending on resin components, which are kept separate within cartridge until delivered via mixer nozzle.</p> <ul style="list-style-type: none"> ▪ foil cartridge system CHUBAPAC ▪ coaxial cartridge system COX ▪ cartridge system side by side SBS 	<p>CFS+ (Cartridge Free System) Innovative resin dispensing system with unique packaging solution, which reduces overall waste. Resin components contained separately within foil until delivered via mixer nozzle.</p>



FEATURES & BENEFITS OF DELIVERY SYSTEMS:

<ul style="list-style-type: none"> ▪ Quick and easy to install ▪ Only solid substrates ▪ Minimal packaging waste - Whole capsule installed in hole ▪ No waste resin ▪ No special tools required ▪ No time limitations - resin only begins to set after stud, rod or rebar is inserted 	<ul style="list-style-type: none"> ▪ For all substrates, including deep anchorages ▪ Many applications from one cartridge ▪ Ability to resume use after stoppages ▪ Small cartridges are compatible with standard, low-cost silicone guns ▪ Simple to store and transport 	<ul style="list-style-type: none"> ▪ For all substrates, including deep anchorages ▪ Easy to dispense ▪ Less waste - Recyclable packaging ▪ The cost-effective solution for many customers
---	--	--

RESIN PRODUCTS AVAILABLE IN EACH SYSTEM:

VINYLESTER: R-HAC-V, R-CAS-V	PURE EPOXY: R-KEX II VINYLESTER: R-KER POLYESTER: R-KEM II, R-KF2 HYBRID: R-KER II	POLYESTER: RM50, RP30 VINYLESTER: RV200
------------------------------	---	--

BONDED ANCHORS - ACCESSORIES

STUDS & SOCKETS (ITS)	HOLE BRUSHES	DISPENSERS & HOLEPUMP	TENSION TESTER

Overview of our range

MECHANICAL ANCHORS - OUR RANGE		
THROUGHBOLTS	SHIELD ANCHORS	HEAVY-DUTY EXPANSION ANCHORS
Throughbolt anchors designed for use in cracked and non-cracked concrete	World's most popular all-purpose expanding shield anchor for use in cracked and non-cracked concrete and other substrates	Heavy-duty expansion anchor, suitable for demanding safety-critical applications
		
FEATURES AND BENEFITS		
<ul style="list-style-type: none"> High performance in cracked and non-cracked concrete confirmed by ETA Option 1 or ETA Option 7 Stainless steel material for the highest corrosion resistance New generation of throughbolt with unique corrosion-resistant coating Throughbolts are suitable for reduced embedment to avoid contact with reinforcement Embedment depth markings help to ensure precise installation Design allows drilling and installation directly through the fixture and reduces overall installation effort 	<ul style="list-style-type: none"> For use in cracked and non-cracked concrete (ETA option 1), hollow-core slabs, flooring blocks and ceramics Shield anchor (shield also available separately) Product recommended for applications requiring fire resistance Bolt lengths suitable for fixture thicknesses of up to 150 mm Ferrule marked with hole diameter to ensure correct installation Optimum geometry for maximum expansion in all recommended substrates Excellent tolerance to variation in hole size 	<ul style="list-style-type: none"> Mechanical anchor for highest tension and shear loads Seismic category C2 for Structural applications. Seismic category C1 for non-structural use in areas with low seismic risk For usage with required fire resistance Option 1 ETA for Cracked and Non-Cracked Concrete
ANCHOR PRODUCTS AVAILABLE:		
R-HPTIIA4, R-HPTIIZF, R-XPTIIA4, R-XPT, R-XPT-HD	RAWLBOLT: R-RBL, R-RBP, R-RBL-PF, R-RBP-PF, R-RBL-E, R-RBL-H, R-RB	SAFETY PLUS: R-SPLII-L, R-SPLII-P, R-SPLII-C, R-SPL, R-SPL-BP, R-SPL-C

WEDGE ANCHORS	SCREW ANCHORS
Internally threaded wedge anchors for simple hammer-set installation	Self-tapping and removable concrete screw anchor for through-fixing installation
	
FEATURES AND BENEFITS	
<ul style="list-style-type: none"> High performance in multiple use in non-structural application confirmed by ETA Product recommended for applications requiring fire resistance Internally threaded to be used with threaded studs, rods or bolts Easy to install by hammer action Slotted sleeve and internal wedge component together facilitate easy setting and expansion Allows bolts or studs to be installed or removed without damaging the anchorage High performance in cracked and non-cracked concrete 	<ul style="list-style-type: none"> Time-efficient installation through streamlined procedure - simply drill and drive Completely removable, allows repeatable use Unique design with patented threadform ensures high performance for relatively small hole diameter Integral washer ensures a neat overall appearance Non-expansion functioning ensures low risk of damage to base material and makes R-LX ideal for installation near edges and adjacent anchors Performance data at two embedment depths (reduced embedment to avoid contact with reinforcement)
ANCHOR PRODUCTS AVAILABLE:	
R-DCA, R-DCL, R-DCA-A4	R-LX-HF-ZP, R-LX-H-ZP, R-LX-CS-ZP, R-LX-HF-ZF, R-LX-H-ZF, R-LX-CS-ZF,

Basics of anchoring - Types of anchors

Torque-controlled expansion anchors

Applied loads are transferred to the substrate via friction between the anchor and the wall of the drilled hole. Friction is the result of expansion force, achieved by applying torque to the bolt or nut, thus drawing a cone component in to an expanding sleeve to create the anchorage.



Undercut anchors

Applied load is transferred to the substrate by mechanical interlock – the result of interaction between the anchor form and the cavity form. The required cavity (or undercut) may be pre-formed within the substrate.



Deformation-controlled expansion anchors

Applied loads are transferred to the substrate via friction between the anchor and the wall of the drilled hole. Friction is the result of expansion force, achieved by displacement of a wedge component, deforming the anchor body and creating the anchorage.



Bonded (injection) anchors

Applied loads are transferred to the substrate by adhesion at the anchor/resin and resin/substrate interfaces. Anchors are supplied as a two-piece set, containing resin (in capsule or cartridge form) and a steel element. In cases involving hollow substrates, a plastic or metal mesh sleeve may be introduced as a third system component. Bonded anchors minimise the introduction of stresses in the substrate material, due to the absence of expansion forces.



Basics of anchoring - Anchor selection factors

In order to select and install an anchor correctly, the user should consider the following factors:

- Environmental conditions (humidity, chemicals, etc.), which are the most important factor for selection of the material and coating type of the fastener (corrosion resistance)
- Base material (type of concrete, solid or hollow masonry structures) – some products (R-KEM II, for example) are suitable for a wide range of substrates, whilst others are recommended for only one
- Anchor spacing and edge distances - Consideration must be given to the minimum distances required to avoid damaging the substrate
- Load-bearing capacity - Data (much of which stems from technical approvals) is provided for each product presented in this catalogue
- Loading type (static/dynamic) and direction (tension/shear /combined)
- Setting data – embedment depths, installation guidelines, etc.

Expanded detail of each of these main selection factors is presented in the following sections.



Corrosion Protection

The only way to provide corrosion protection for steel fasteners is through the use of specialized protective coatings. The coating processes are especially important to us, therefore we perform them ourselves.

The modern Rawplug processing lines guarantee corrosion protection in accordance with the highest requirements of our clients. This is achieved by means of galvanizing processes, zinc flake systems, or comprehensive multilayer coatings.



Production of anchors

Corrosion Protection of Anchors

Anchors are used in a wide range of applications and may be utilized indoors or outdoors. Metal corrosion takes place everywhere, regardless of the application.

The progress of corrosion depends on concentrations of chemical compounds in the air, on electrochemical processes, and on air humidity. These are processes of deterioration of metals and alloys, which result from reactions with their surroundings (corrosive environment).

In order to understand the essence of protective coatings, one must first understand the phenomenon of corrosion.



HDG 504 hrs



Zinc flake coating 504 hrs

Corrosion Process

Corrosion is divided in respect of the corrosive environment in which the given metal or alloy is placed, of the mechanism of corrosion processes, and of the nature of metal deterioration.

Types of Corrosion Depending on the Corrosive Environment

- **atmospheric corrosion** - related to precipitation, air humidity, atmospheric pollution,
- **gaseous corrosion** - in dry and mostly hot gases,
- **water corrosion** e.g. in sea water or in river water,
- **earth corrosion** e.g. in soil,
- **microbiological corrosion** (biocorrosion),
- **corrosion occurring under the influence of microorganisms** (mostly bacteria and fungi) and products of their metabolism (these products create a corrosive environment),
- **corrosion caused by stray currents** - this occurs mostly in cities, where many electrical appliances are earthed (current flows through soil).



after 960 hrs

ZINC FLAKE COATING
Zinc electroplated expander HPT-II-ZF

HDG
Stainless steel expander XPT-HDG

Production of anchors

Types of Corrosion Depending on the Mechanism of Corrosion Processes

Electrochemical corrosion

Occurs in electrolyte environments, in fresh and salt water, in wet gases, and in soil containing moisture.

Chemical corrosion

Occurs mostly in dry gases and non-conductive liquids (non-electrolytes), e.g. in some liquid organic substances. The result of corrosion processes is the deterioration of metal, which is observed mostly on surfaces as an accumulation of solid products of reaction, e.g. oxides, rust, scale. If the products of reaction fall off the metallic substrate, irregularities or pitting of the originally smooth surface can be observed.

Types of Corrosion Depending on the Nature of Corrosive Deterioration

Pitting corrosion

One of the most commonly found types of local corrosion, occurring in relation to the presence of aggressive anions in a corrosive environment.

Uniform or non-uniform general corrosion

Comprises attacks on and the deterioration of the entire surface.

Fatigue corrosion

Occurs due to a combination of an aggressive corrosive environment and cyclical or variable stresses, which causes the metal to break. The influence of stress infringes the protective layer (passive layer), which results in the unprotected (exposed) metal being attacked. Fatigue corrosion may occur in any water environment (steam, hot water, natural salt water, fresh water, condensation water, chemical solutions, moist air).

Intergranular corrosion

One of the most dangerous types of corrosion. Attacks stainless steels along grain boundaries. It is caused by chemical egregation, e.g. of chromium on the grain boundary during heat treatment or during welding. These eductions constitute anodic areas of reduced corrosion resistance, and the centre of the grain performs the role of a cathode. Pitting corrosion disturbs the cohesion between grains, resulting in the reduction of mechanical properties.

Stress corrosion

Is caused by stresses resulting from external forces, as well as internal stresses e.g. from cold bending or welding. Stress corrosion is characterized by strong branching directed perpendicularly to the stress. It manifests itself by formation of cracks, which usually run through grains in stainless steels.

Local corrosion

Including stain corrosion, point corrosion, pitting corrosion, intergranular corrosion, or crevice corrosion.

Contact (galvanic) corrosion

Caused by contact of two metals or alloys of different potentials, resulting in the creation of a galvanic cell. Effectiveness of operation of the cell increases with the potential difference between the two contacting metals in a corrosive environment. Connection of two metals of different electrochemical potential results in the less noble metal being subject to intensive dissolving.

Crevice corrosion

Appears in crevices and structural recesses, under seals, bolt and rivet heads, under sediments and scale, and in all kinds of cracks. Crevice corrosion occurs as a result of gradual decay of the passive layer in crevices in which this layer cannot regenerate due to hindered aeration and obstructed oxygen inflow.

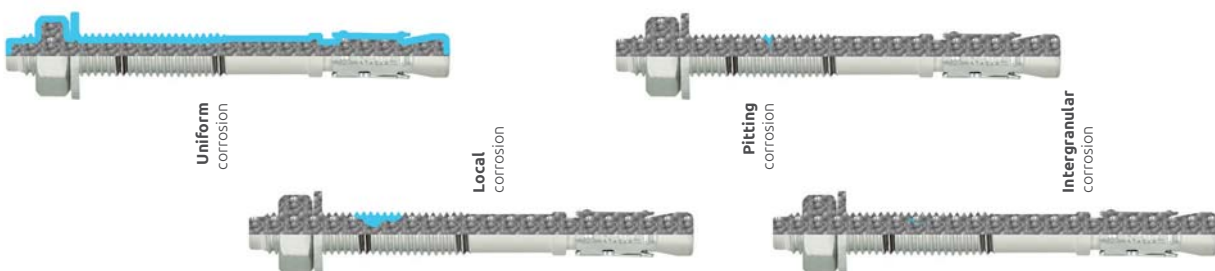

Production of anchors

Environmental corrosion categories

Selection of anti-corrosion protection of a product is strongly simplified by the ISO 12944 norm. It is a source of information on corrosion protection of steel constructions and use of appropriate coatings.

CORROSION CATEGORY	WEIGHT LOSS PER SURFACE UNIT / THICKNESS REDUCTION (AFTER FIRST YEAR)				EXAMPLES OF TYPICAL ENVIRONMENTS	
	NON-ALLOY STEEL		ZINC		EXTERIOR	INTERIOR
	WEIGHT LOSS IN g/m ²	THICKNESS REDUCTION IN μm	WEIGHT LOSS IN g/m ²	THICKNESS REDUCTION IN μm		
C1 VERY LOW	<10	<1,3	<0,7	<0,1	-	Interior of air-conditioned premises with clean atmosphere (e.g. shops, offices, hotels)
C2 LOW	>10 do 200	>1,3 do 25	>0,7 do 5	>0,1 do 0,7	Atmosphere with low pollution and dry climate; mainly rural areas	Unheated buildings where condensation may occur
C3 AVERAGE	>200 do 400	>25 do 50	>5 do 15	>0,7 do 2,1	Residential and industrial atmosphere with moderate pollution of SO ₂ . Coastal areas; low salinity atmosphere	Light industry with humidity and air pollution (food production, laundry facilities, etc.)
C4 HIGH	>400 do 650	>50 do 80	>15 do 30	>2,1 do 4,2	Industrial and coastal areas; medium salinity atmosphere	Chemical factories, swimming pools, offshore ships, etc.
C5I VERY HIGH (industrial)	>650 do 1500	>80 do 200	>30 do 60	>4,2 do 8,4	Industrial areas with highly-aggressive atmospheric conditions and high humidity	Buildings and areas with condensation of water and high pollution
C5M VERY HIGH (marine)	>650 do 1500	>80 do 200	>30 do 60	>4,2 do 8,4	Coastal and offshore areas with atmospheric conditions of high salinity	Buildings and areas with condensation of water and high pollution

Electrochemical corrosion

Processes of electrochemical corrosion occur when metal or alloy is present in an environment constituting an electrolyte, i.e. mostly in water solutions. River water and lake water contain sufficient amounts of inorganic compounds, and sea water contains up to 3% of dissolved salts, therefore they are good electrolytes.

Corrosion Macrocells and Microcells

Local microcells are created as a result of contact of metal and electrolyte. Even the cleanest metal surface is not uniform at the microscopic level. Metals have a grainy crystalline microstructure, and grain boundaries have a less ordered structure than grain interiors. The energy of grain boundaries is higher than the energy of the grain itself, therefore on contact with an electrolyte the grain boundaries become an anodic area, while the grain area, having lower energy, becomes a cathodic area.

Corrosion macrocells are created by the contact of two metals or alloys of different stationary electrode potential which are

present in an electrolyte environment (contact corrosion). Galvanic effect in such cells occurs at potential difference greater than 0.05 V.

Corrosion microcells are different from galvanic cells in that they operate as short-circuited immediately upon contact with an electrolyte. Metal deterioration always occurs in an anodic area.

During the operation of a corrosion cell, a current is flowing in metal, and cell poles are subject to polarization. Polarization inhibits the corrosion process and is a desirable phenomenon. However, some depolarizers, such as oxygen from air or hydrogen ions, are acting in electrochemical corrosion processes.

Products created in an electrochemical corrosion process are reacting with one another. If some sparingly soluble products are created as a result of this reaction, the corrosion process is inhibited.

Production of anchors

The table below presents a summary of the most common metal types - fastener material and substrate material - and the direction of the expected corrosion centres. Metal of the fastened element is not subject to galvanic corrosion and benefits from the phenomenon of galvanic protection (low when the difference of electrochemical potential is small, and getting higher with increasing potential difference).

Galvanic effect is influenced by the surface area of the elements constituting the macrocell. If the surface area of the substrate material (sheet metal or structure) is smaller, corrosion is accelerated, and if the surface area of the substrate material is greater, corrosion is slower. The greater the potential difference, the more pronounced this effect is.

Corrosion Cells and Directions of Corrosion Centres

FASTENER METAL	STAINLESS STEEL	GALVANIZED STEEL	ZINC-PLATED STEEL	ZINC ALLOYS	LEAD	BRASS
METAL OF ELEMENT FASTENED						
STAINLESS STEEL	○	▲	▲	▲	▲	▲
GALVANIZED STEEL	◄	○	○	○	◄	◄
ZINC-PLATED STEEL	◄	○	○	○	○	◄
LOW-CARBON STEEL	◄	▲	▲	▲	○	◄
ALUMINIUM ALLOYS	◄	▲	▲	▲	○	○
ZINC ALLOYS	◄	○	○	○	◄	◄

○ contact between these metals is possible

▲ fastener metal is attacked

◄ fastened element metal is attacked

Protective Coatings

Under the influence of corrosion, steel elements are subject to gradual deterioration and embrittlement, losing their technical parameters and putting the user at risk of hazardous operation or, at least, damage. Therefore the key parameter for Rawlplug fasteners is the highest quality of their corrosion protection.

Care for the quality of the final product requires us to control every stage of the coating process. In our factory we have facilities that allow us to obtain any type of corrosion protection in accordance with the requirements or specifications of our clients. The wide range of corrosion protections offered by Rawlplug, and the accompanying manufacturing processes, guarantee the highest quality of the final product.

Systematics of Protective Coatings

In respect of composition, protective coatings can be divided into

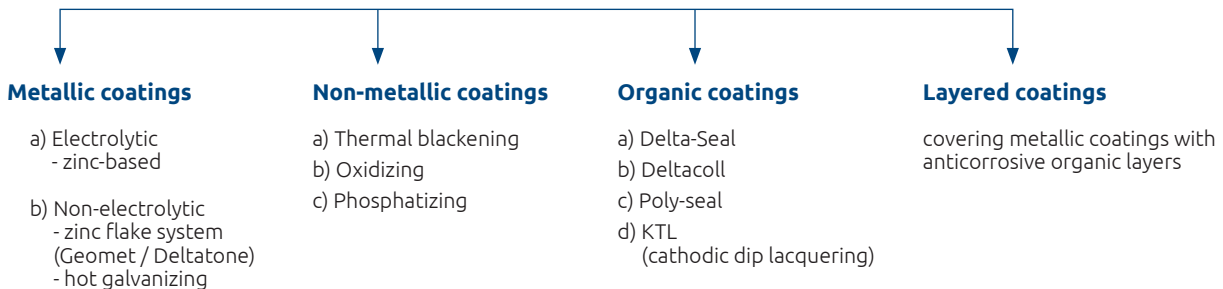

Production of anchors

When preparing a product specification, the limited application of protective coatings executed using Cr(VI) must be taken into account. In accordance with the directive of the European Parliament and the European Council 2000/53/EC, it is forbidden to use hexavalent chromium Cr(VI) as corrosion protection in all passenger automobiles that will be approved for marketing after 01 July 2007.

In accordance with the regulation, the same prohibition has been in force for nearly all products of the electromechanical and electronic industries since 01 July 2006. The trend to limit Cr(VI) in its application is expanding to all branches and fields of life.

The following corrosion protection layers contain Cr (VI) and therefore are covered by the above mentioned prohibition of application:

- yellow chromating, galvanic zinc and zinc-alloy coatings
- black chromating, galvanic zinc coatings
- DACROMET® zinc-alloy coatings

Note: anticorrosive coatings in Europe rarely contain Cr(VI) anymore, while chromating containing Cr(VI) is still being used in Asia!

Characteristics of Rawlplug Coatings

1. Electrolytic Zinc Coatings

Standard - as always

Various capabilities of customization

Galvanizing is still the standard for most fasteners. Galvanically deposited zinc coatings are classified as protective, i.e. aimed exclusively at providing corrosion protection for the substrate metal.

Zinc coatings protect the substrate metal as a result of their anodic dissolution in a corrosion cell. Therefore it can be easily concluded that the thicker the executed zinc coating layer is, the longer it will effectively protect the covered item.

In order to approximately determine the average period of effective protection of the zinc coating, assuming that the coating has no defects, it is necessary to know the coating thickness (from 5 to 30 micrometres on average) and the type of natural atmosphere in which the product will be present. There are four types of natural atmospheres which can be assigned different rates of corrosion of the zinc coating:

- **industrial** - corrosion rate 5-7 micrometres per year,
- **urban** - corrosion rate 3-5 micrometres per year,
- **coastal** - corrosion rate 3-7 micrometres per year,
- **rural** - corrosion rate 1-2 micrometres per year.

The described average reductions of coatings do not take into account any additional corrosion factors occurring locally.

The daily capacity of our zinc works exceeds 60 tons of products. The zinc works at the Rawlplug factory in Łańcut are equipped with mechanical cleaning machines, product zinc-plating lines with more than 40 baths, and a dehydrogenation oven. The technological process of product zinc-coating takes approximately 2.5 hours and, contrary to the common opinion, is a comprehensive multi-staged process consisting of as many as 14 processes. Omitting or shortening any of the operations results in losing the quality of the protective coating.

The galvanizing process comprises the following operations:

- Chemical degreasing - occurring in an alkaline bath, duration is 8min. at temperature of 45°C - 50°C
- Rinsing - with constant water inflow, duration approximately 30s.
- Etching - this process prepares the product surface for coating with zinc, duration approximately 16min.
- Rinsing - in three successive baths, duration approximately 20s.
- Electrochemical degreasing - the last precise degreasing process before application of the zinc coating.
- Rinsing - in three successive baths, duration approximately 20s.
- Activation before galvanizing.

- Rinsing - in three successive baths, duration approximately 20s.
- Galvanizing - duration of application of the zinc coating varies, depending on the coating thickness, from 40 minutes (5µm thick coating) to 120 minutes (15µm thick coating).
- Rinsing.
- Brightening in nitric acid.
- Passivation of the product.
- Rinsing.
- Drying.

Production of anchors

Harmful hydrogen penetrating into steel during the galvanizing process may cause a subsequent loss of plasticity or cracks, even at the recommended design load. The phenomenon of hydrogen embrittlement is related to fasteners from class 10.9 up, i.e. products of high tensile strength, high hardness, and surface-hardened. The process reducing the quantity of harmful hydrogen in steel during galvanizing is "dehydrogenation" by soaking. This process is performed in the Rawlplug factory in Łańcut in accordance with the standard ISO 4042. Products are soaked in the oven at a specific temperature for approximately 6 hours. In order to avoid defects related to hydrogen embrittlement, products are placed in the oven within no more than two hours from the moment of being covered with zinc. After soaking the products are cooled down, then they

are subjected to quality control, where specialized and experienced staff ensure only the highest quality products are approved for sale.

In the Rawlplug factory in Łańcut we execute the following type of galvanizing in accordance with the standard ISO 4042.

- **thin-layer galvanizing** – coating thickness is from 5 μm to 15 μm in yellow, blue, and colourless passivation, and corrosion resistance of such coatings, depending on their thickness, lasts between 6 and 72 hours until white corrosion is obtained, and from 24 to 144 hours for red corrosion

Schematic construction of galvanic coating

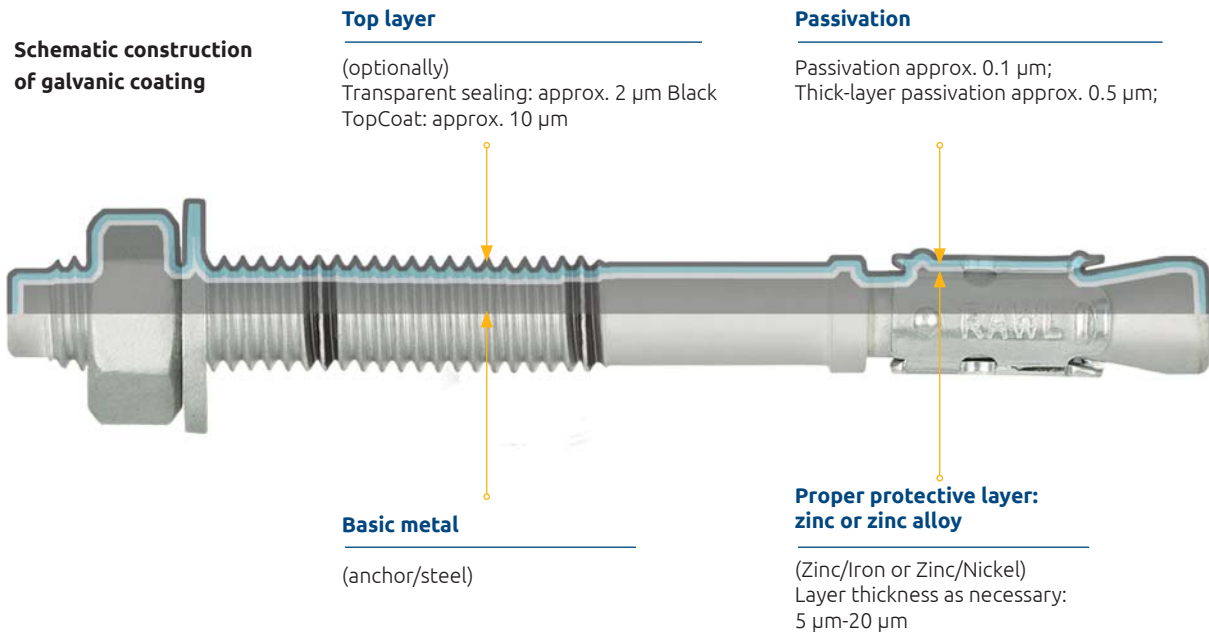

Production of anchors

2. Hot Dip Galvanizing Zinc Coating

Increased corrosion resistance

Hot dip galvanizing is applied to products with the use of immersion method. Previously prepared products are placed in liquid Zinc, which allows to cover even fixings of the most complicated shape with a homogenous protective layer.

Product of the hot dip galvanizing process is a layer resistant to corrosion, abrasion or mechanical damage. Depending on the layer thickness, environmental conditions, and mechanical erosion such layer can stand 10 – 100 years.

An advantage of such solution is greater metal protection than in case of standard zinc-plating, with same minimal negative

environmental impact and lack of significant cost increase. Effect of such action is receiving aesthetic anti-corrosion layer with excellent technical parametres.

Hot Dip Galvanizing benefits from the diffusion effect. Zinc atoms penetrate external layer of the steel. As the dip is performed in high temperature (ca. 450°C), a zinc-steel alloy is created on the surface of the product. Such coating is characterized with multilayer structure, including a layer of zinc, zinc-iron and alloy phases. It guarantees inseparability of the coating with its substrate.

HDG coatings for Rawlplug are created with use of modern zinc coating furnaces in accordance in compliance with regulations of PN EN ISO 10684 and 1461.

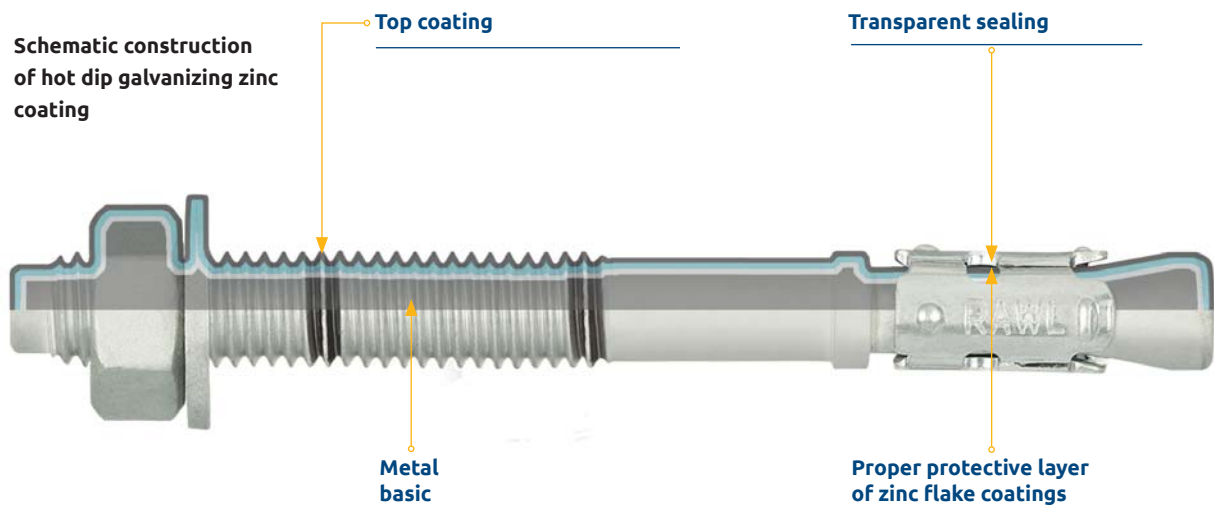

3. Non-Electrolytically Applied Zinc Flake Coatings

Very good corrosion resistance

Elimination of hydrogen embrittlement

Zinc Flake Coatings

Zinc-aluminium flake coatings have gained worldwide recognition in specialized automobile, aviation, and construction industries. Various basic products and topcoat lacquers with a wide range of properties are applied e.g. on connecting parts and pressed parts.

They satisfy the high requirements imposed by industry. Organic and inorganic top coatings have been improved in respect of specific properties of lamellar zinc coatings. Combination of basic coating and top coating has largely matched the requirements imposed by industry which could not have been satisfied before.

Production of anchors

Non-electrolytically applied zinc coatings have found wide application in industry, due to their very good anticorrosive properties (resistance to salt spray mist considerably above 1000 hours, according to PN-EN ISO 9227), very good resistance to temperature, ability to select the required friction coefficient, and the ability to use modern methods of application in the coating process. Non-electrolytically applied zinc flake coatings belong to the most modern methods of corrosion protection.

Zinc coatings consist mostly of a mixture of zinc and aluminium (generally in proportion of 95:5), an electrically conductive binding agent and, depending on the requirements, an integrated lubricant - in order to adjust the friction coefficient.

The basic properties of non-electrolytically applied zinc flake coatings:

- contain no substances harmful to health
 - not only chromium but also lead and cadmium;
- have special resistance to high temperature;
- have exceptional resistance to mechanical loads and chemicals;
- exhibit no hydrogen embrittlement;
- allow the selection of the required friction coefficient;
- can be applied using common methods such as: dipping, centrifugation, or spraying.
- are ecological - satisfy the environmental protection requirements in automobile industry and the requirements of the European Directive 2000/53/EC on end-of-life vehicles.

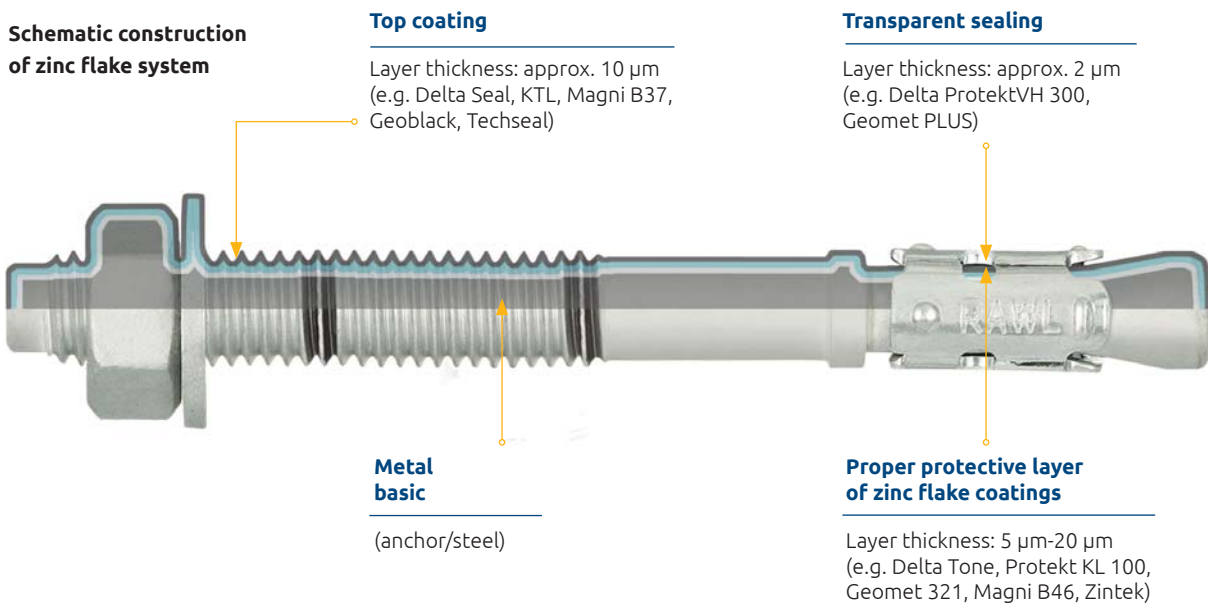

Coatings of zinc flakes have a thickness in the range of 5-12 micrometres and, as opposed to galvanic coatings, are thicker on threads and in recesses, and thinner on peaks and edges. For fine threads up to M4 it is more difficult to pass the gauge but in most situations it will not hinder the assembly with nuts and in internal holes.

As a result of dipping application of zinc flake coatings, a thicker coating can be formed in recesses of elements, (e.g. in cavities and sockets of fasteners and on elements with a complex shape), thus providing a better corrosion protection than in the case of galvanic coating, because galvanic coatings are thinner in these areas. However, in some cases the increase of coating thickness in cavities and sockets may pose a problem.

Production of anchors

Basic Coatings

The primary goal of basic coatings is to protect the steel substrate from corrosion by active dissolution of zinc. Since zinc is less noble than steel, it corrodes first, when both metals stay in electrical contact. When the coating becomes damaged, e.g. by scratching, then zinc, and not steel, is subject to corrosion. This happens until the entire matrix is destroyed. Zinc is built into the coating in the form of fine flakes, several micrometres thick.

Small flake size makes it possible to obtain very thin coatings of thickness, approximately 4 µm. These flakes are in contact with one another, and as a result they constitute a layer acting as a zinc matrix. In order to obtain a corrosion protection level comparable to conventional coatings containing chromium (VI), the zinc flake coatings - which contain no compounds of chromium (VI) - are covered with top coatings as a complement to the basic coatings.

Top Coatings

Top coatings should protect the metals (iron, zinc) from corrosion. The corrosion process is accelerated by the presence of water coming from the surroundings (air humidity, influence of the environment, etc.). Therefore the top coatings constitute a barrier isolating the metal from the influence of corrosive factors.

The top coatings extend the period of electrochemical action of zinc coatings, and thus increase the durability of the protection. The hardening temperature for the top coatings is within the same range as for the basic lacquers.

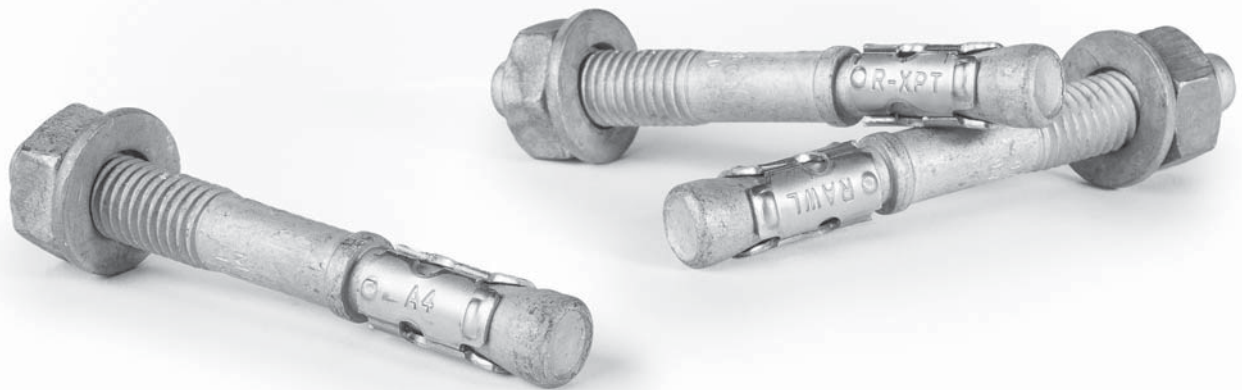

R-XPTIIA4

Protective Coating Application Technology

Pretreatment of Parts

Coatings, as in the case of most applications, are applied onto clean and dry steel surfaces free from dust and grease. Depending on the history, purpose, and geometry of the parts, various pretreatment methods are used.

However, care should be taken so that the chosen pretreatment method does not cause hydrogen embrittlement. An example may be etching leading to diffusion of hydrogen into steel.

Dipping and Centrifugation

Coatings on elements with a large surface area are usually applied using the dipping method. Elements are placed in a basket which is dipped in a specially designed container. Paint covers the entire surface of the elements. The movement caused by slow rotation of the basket may improve the quality of the painting process and lead to the elimination of air bubbles.

After application, the coating should be subjected to hardening. Several parameters influence the dipping process. The most important ones are: dipping time, rotation speed, rotation time, and load size.

Dipping in paint and drying, while maintaining appropriate conditions, is especially suitable in the case of parts with exceptional geometry, such as screws, bolts, or other complex elements.

Production of anchors

Hardening

Another operation is hardening of the coating. Hardening of coatings is performed in various types of ovens. Painted elements are transported from the basket on a slowly moving belt.

The first part of the oven is the so-called evaporation zone, where the solvents, or water in the case of water-based systems, evaporate at a temperature of approximately 80-100°C. Then the coatings are hardened at a specific temperature, depending on the applied coating. After hardening, the elements are cooled down to an ambient temperature (25°C or lower).

Zinc Flake Coating Systems Applied on Rawlplug Fasteners

Products manufactured in the Rawlplug factory are coated using zinc flake coating systems of the highest quality:

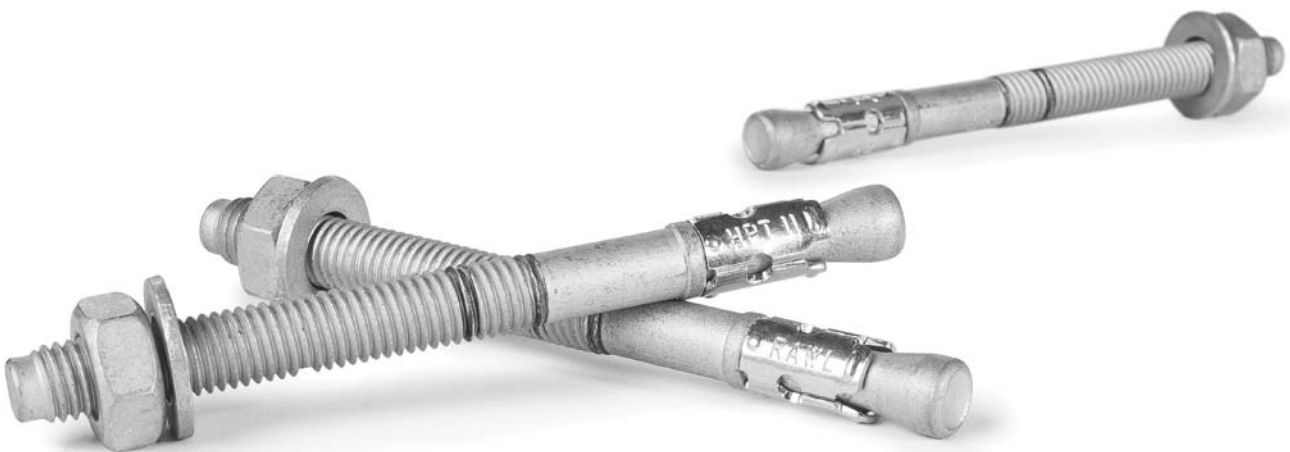

R-HPTIIZF

GEOMET®

Geomet® is a water-based zinc flake coating that replaces Dacromet®. It has been developed by the combined resources of the Dacral Group of companies located in France, USA, and Japan. Geomet® is known and accepted worldwide, and it satisfies the requirements of all major OEMs across the world.

Appearance

The coating looks silvery-grey on the surface, and may be covered with colourful organic coatings.

Efficiency Information

We can say that Geomet® provides fourfold protection against corrosion.

- Barrage protection: overlapping zinc and aluminium flakes constitute an excellent barrier between the steel substrate and the corrosive medium.
- Galvanic protection: zinc corrodes in order to protect steel.
- Passivation: metal oxides slow down corrosion reactions of zinc and steel, providing three times better corrosion protection than pure zinc.
- Self-regeneration: zinc oxides and carbonates move to the damaged coating areas, repair them actively, and renew the protective layer. Thanks to this phenomenon, thin layers provide corrosion protection for a period ranging from 600 to over 1000 hours.

Production of anchors

Most Important Advantages of the Coating

- Aesthetically pleasing appearance.
- Material cohesion.
- Adherence to substrate.
- Possible application for parts with plastic or glued additions.
- More than 600 hours protection when tested in inert salt spray mist.
- If necessary, execution of additional covering with specialized top coatings is possible.
- Electrically conductive, suitable for earthing applications (top coating is not an insulator).
- Thin layer of coating application, approximately 5-7 μm , allows its use for smaller parts, with low risk of filling recesses and with no problems related to thread tolerance, there is no need to reduce the thread size below the standard size.
- Compatible with co-operating parts, also covered with Geomet[®] 500.
- Cost-effective.
- For small elements (M3-M6 without filling recesses).
- No hydrogen embrittlement.
- Water-based.
- Excellent bi-metallic protection (especially with aluminium).
- BMW GS 90 requirements.

Types of Materials

Geomet[®] is available in three similar varieties. These are:

Geomet[®] 500

Designed especially for the covering of fasteners and small details in order to obtain the corrosion resistance of 600 hours and the ability to control lubricity. It can be modified by adding a surface lubricant. It is a direct successor of Dacromet[®] 500.

Geomet[®] 321

This coating can be applied to pressed elements, fasteners, and large elements. It is usually applied where a corrosion resistance above 720 hours is required, and it has a sealed top coating that can be lubricated if necessary.

Geomet[®] 720

This material is applied where high resistance in inert salt spray mist is required at low thickness, even up to 1500 hours.

Influence on Environment

Water-based zinc flake coatings require no separate solvents or other equipment for cleaning, therefore they are the most environmentally friendly of all zinc flake coatings. This coating, while having a thin layer, provides good corrosion resistance and simultaneously has low impact on the environment.

DIFFERENS CORROSION PROTECTION VARIANTS



Production of anchors

Selection of Optimal Protective Coating

Having a wide range of available corrosion protections, it is of critical importance to optimally select the type of protection for a product application. Having in mind the appropriate relation of product quality and cost, our research and development department optimizes the coating quality adequately to the product specification provided by the client.

A test illustrating the difference in quality of corrosion resistance of a fastener is the accelerated corrosion test. This examination is performed in order to give an idea of the relative efficiency of some coatings. It is also used for quick determination of coating quality (although presently some modern coatings are subjected to accelerated examinations for more than 1000 hours, therefore they are not "quick").

The most common examination is performed in 5 % inert salt spray mist (according to BS 7479, ISO 3768, or ASTM B117). This examination is used by most manufacturers in order to estimate the quality of execution of many coatings (except for nickel-chromium coatings). The result is the protection specified as the time necessary for the first appearance of corrosion [h 5% s/s].

Other tests of corrosion protection include:

- Kesternich - examination in sulfur dioxide spray mist.
- A.S.S. - Acetic acid salt spray mist BS 7479 ISO 3769.
- C.A.S.S. - Accelerated examinations in copper salt spray mist.
- BS 7479, ISO 3770 - used for chromium-nickel coatings.

The component material of a coating is selected due to its mechanical properties, malleability, plasticity, strength properties, etc. Subsequent coatings of different materials provide protection and contribute to a long period of usable life. A coating often has more than one property, and in order to give it various properties, covering with many coatings is used, i.e. one layer is applied onto another.

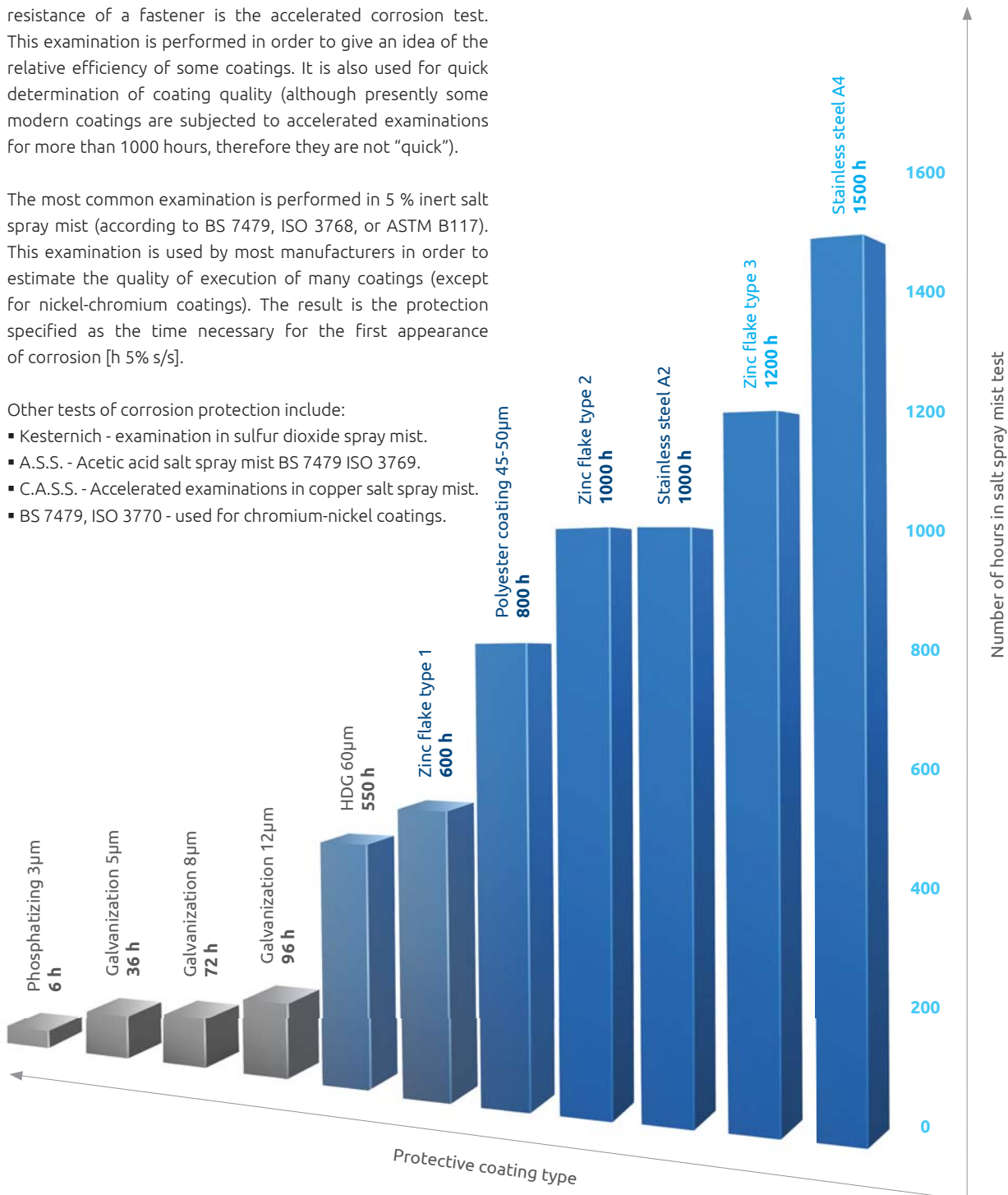

Production of anchors

Coating layers quality control

In order to ensure highest quality of our products, samples are taken from every part of products covered with coating for detailed examination to check its structure and thickness. Tests are performed with use of Daltoscopes and special matrix.

In order to maintain 100% control over process, everyday tests of reagents concentration and process parameters are performed in our chemical lab. Rawlplug factory cooperates only with carefully selected suppliers of substances and coatings. Moreover due to cooperation with scientific institutions we represent highest level of knowledge, allowing us to fulfill customers' expectations in terms of corrosion protection of anchors.



Rawlplug protection layers environmental impact

Rawlplug protection layers meet requirements of following EU industrial directives:

- 2000/53/EC (ELV) - automotive industry,
- 2011/65/UE (ROHS 2) - electrical and electronic devices production industry,
- 1907/2006/WE (REACH) candidate list for dangerous substances (SVHC).

Protection layers used in Rawlplug products are secure for environment. We strive to ensure high effectiveness and lowest negative environmental impact of galvanizing process. We removed cobalt salts from zinc electroplating baths in order to reduce use of substances dangerous for health and natural environment. Through optimization of working concentration thanks to laboratory analysis we reduce amount of substances and chemical compounds used for particular stages. Lower operating concentration in comparison with

other galvanic processes used to ensure corrosion protection of alloy and carbon steel. The process of zinc-electroplating itself is performed in the ambient temperature, which is another benefit due to lower energy consumption.

Being responsible for the environment, the dangerous waste originating from zinc-electroplating processes is being sent to specialist recycling and utilization companies. Other waste is processed by factory's sewage treatment plant. Parameters of waste is controlled in order to ensure accordance to legal requirements in this area according to regulations.

We understand the relationship between the products we build and the environments that they are used in, and have built environmental awareness into the entire lifecycle of our products and operations.

Sustainable **RAWLPLUG**
Environment



Research and development

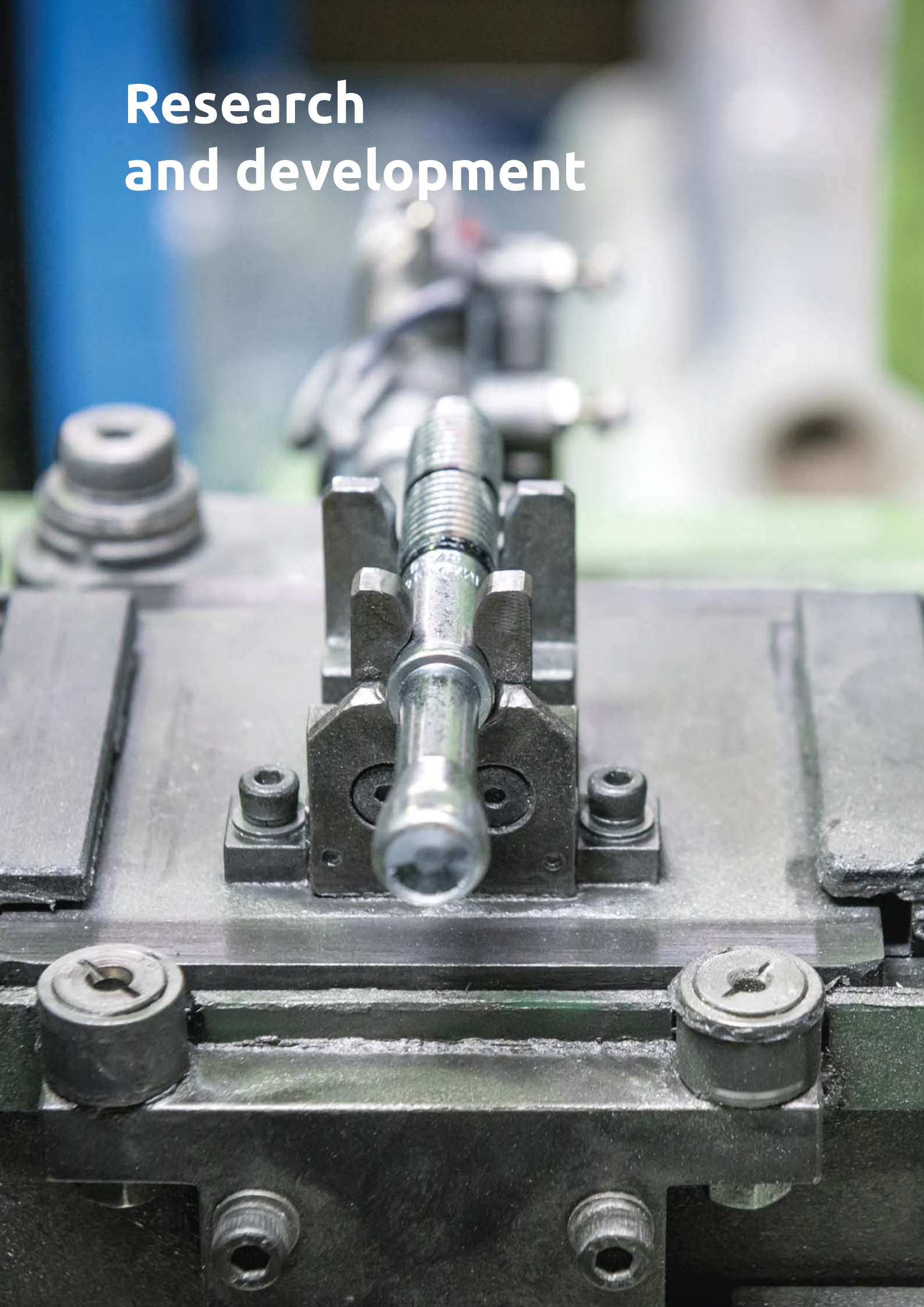

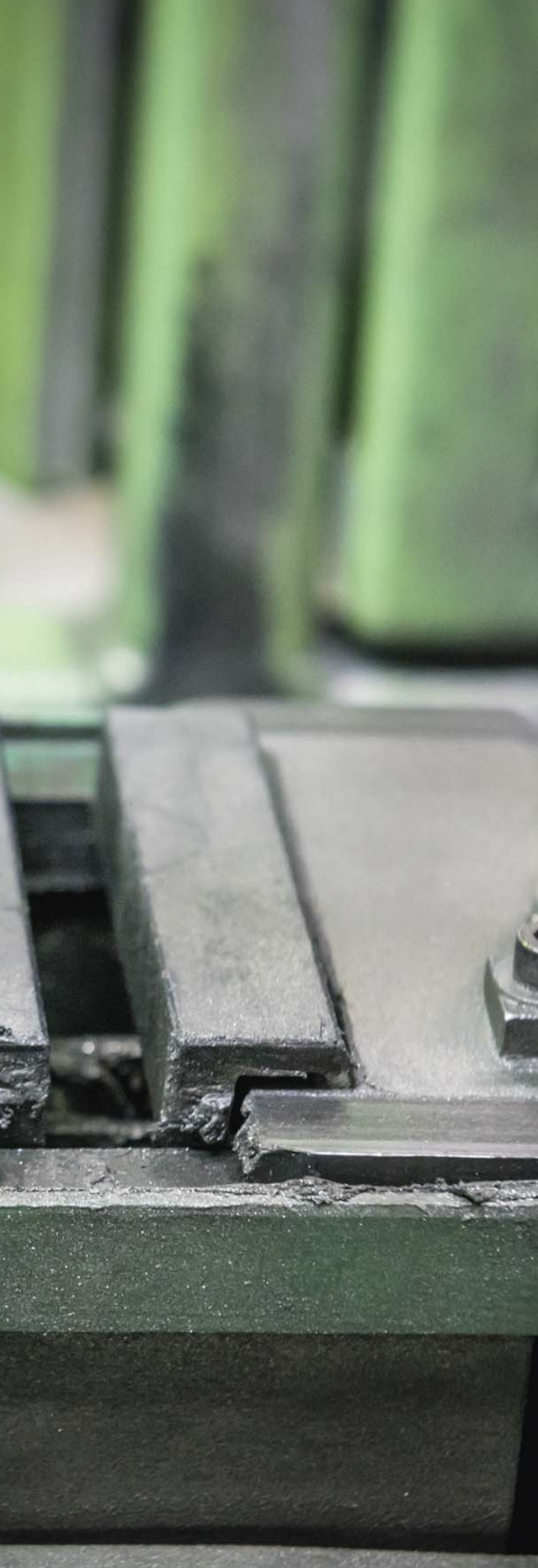

Research & development and quality control background

- Analysis of customer's expectations is the foundation of our activity. Recognition of needs and identification of solutions leading to their fulfillment is a starting point for our product development activities. The operation model involves practical knowledge about product use and expertise in terms of fixing assortment production technology.

In order to achieve the most efficient and functional products, Rawlplug anchors product development process is performed in close cooperation with production plant. Consideration of all of the aspects of their design in accordance to appropriate departments of the production plant leads to a synergy which can be obtained only directly by a producer.

From sourcing suppliers who can provide appropriate materials, through design of geometry, mechanical and heat treatment, through quality control and even appropriate packaging considering sustainable development, excellence is our aim. Even if the way to reach it involves going the extra mile.

- **Own production plant with an array of advanced technologies of material treatment and laboratory examination potential enables us to thoroughly develop our product range. Taking the advantage of testing numerous variants of anchors with different modifications and comparison enables us to achieve highest quality and uncompromised parameters.**

RAWLPLUG®

Trust & Innovation. Since 1919.

Research and development

Research & development

Rawplug R&D department consists of a number of facilities specialized in various areas located in company's headquarters or production units. Proximity to areas where particular processes take place enables provide constant control of quality and effects of innovations implemented in the production process. Research and development department plays crucial role in the continuous process of upgrading Rawplug Bonded and Mechanical Anchors range.



Measurement lab:

- Geometric measurements of products accordingly to technical specifications or norms
- Preparation of MSA measurement systems analysis
- Performance of machine and process capabilities examinations (SPC)
- Testing of minimum breaking loads MB min
- Friction coefficient measurement
- Optimum tightening torque level for special parts

Chemical lab

- Chemical composition analysis
- Measurement of layers thickness with magnetic, weight and X-ray methods
- Corrosion resistance salt spray testing
- Chemical and physics-chemical analysis of various substances
- Climate chamber cycles examination accordingly to specification
- Examination of paint layers adherence

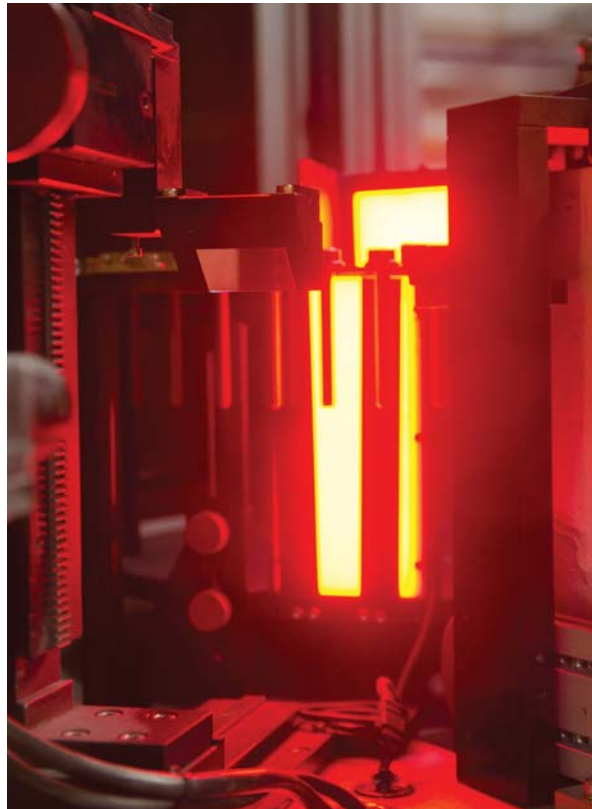

Research and development

Metallography lab:

- Measurement of core microhardness HV10, surface HV3,0
- Microscopic steel structure assessment, microstructure examination
- Examination of fibre layout, decarburization, material faults
- Diffusion layers quality check
- Layers thickness microscope measurement accordingly to ISO 1463
- Hardenability of materials examination



Production quality control team performs examinations derived from ISO 898 norm, such as;

- Rm resistance
- HV, HRC hardness
- Rp yield strength
- Tension under proof load
- Extention A%
- Narrowing Z%
- Head solidity / test on wedge
- Impact performance (up to 60°C)
- Surface integrity according to ISO 6157
- Sets tests accordingly to ISO 15048
- Hydrogen embrittlement setting accordingly to ISO 15330
- Swelling proofs to detect material faults

Norms, certificates, insurances

EN ISO 9001:2008

Certificate of compliance with quality management system including process approach in management

ISO/TS 16949:2009

Certificate of compliance of system quality management with technical specification requirements in terms of production and sales of automotive industry products

ISO 14001:2004

Certificate of compliance with requirements of system environmental management

EN 15048-1:2007

Plant quality control department certificate of compliance of non-preloaded structural bolting assemblies for construction industry use according to 89/106/EEG directive

AD 2000

Certificate of compliance with directive 97/23/EG and AD2000 instruction - Merkblatt W0 for bolt products used for pressure devices

TÜV

Certificate of compliance for production of bolt products used in construction industry on German market

OHSAS 18001:2007

Certificate of compliance with system management in terms of safety at work regulations accordingly to OHSAS 18001:2007 standard

Rawplug Support

European Technical Assessments and Approvals

ZUS Technical and Test Institute for Construction Prague
Prosečská 81/176a
190 00 Prague
Czech Republic
eota@zuz.cz

Member of **EOTA**
www.eota.eu

European Technical Assessment **ETA 17/0185** of 02/10/2017

Technical Assessment Body issuing the ETA: Technical and Test Institute for Construction Prague
Trade name of the construction product: Rawplug R-HPT11A4 Stainless Steel Throughbolt
Product family to which the construction product belongs: Product area code: 33
Torque controlled expansion anchor for use in cracked and uncracked concrete
Manufacturer: Rawplug S.A.
Ul. Kwiczyńska 6
51-416 Wrocław
Poland
Manufacturing plant: Manufacturing Plant No 2
This European Technical Assessment contains: 12 pages including 10 Annexes which form an integral part of this assessment
This European Technical Assessment is issued in accordance with regulation (EU) No 305/2011, on the basis of: EAD 330232-00-0601
This version replaces: ETA 17/0185 issued on 20/03/2017

Translations of this European Technical Assessment in other languages shall fully correspond to the original issued document and should be identified as such.
Communication of this European Technical Assessment, including transmission by electronic means, shall be in full (excepted the confidential Annexes referred to above). However, partial reproduction may be made, with the written consent of the issuing Technical Assessment Body - Technical and Test Institute for Construction Prague. Any partial reproduction has to be identified as such.

ETA 17/0185 of 02/10/2017 - Page 1 of 12 090-03809

ZUS Technical and Test Institute for Construction Prague
Prosečská 81/176a
190 00 Prague
Czech Republic
eota@zuz.cz

Member of **EOTA**
www.eota.eu

European Technical Assessment **ETA 17/0184** of 02/10/2017

Technical Assessment Body issuing the ETA: Technical and Test Institute for Construction Prague
Trade name of the construction product: Rawplug R-HPT12ZF Zinc Flake Throughbolt
Product family to which the construction product belongs: Product area code: 33
Torque controlled expansion anchor for use in cracked and uncracked concrete
Manufacturer: Rawplug S.A.
Ul. Kwiczyńska 6
51-416 Wrocław
Poland
Manufacturing plant: Manufacturing Plant No 2
This European Technical Assessment contains: 12 pages including 10 Annexes which form an integral part of this assessment
This European Technical Assessment is issued in accordance with regulation (EU) No 305/2011, on the basis of: EAD 330232-00-0601
This version replaces: ETA 17/0184 issued on 20/03/2017

Translations of this European Technical Assessment in other languages shall fully correspond to the original issued document and should be identified as such.
Communication of this European Technical Assessment, including transmission by electronic means, shall be in full (excepted the confidential Annexes referred to above). However, partial reproduction may be made, with the written consent of the issuing Technical Assessment Body - Technical and Test Institute for Construction Prague. Any partial reproduction has to be identified as such.

ETA 17/0184 of 02/10/2017 - Page 1 of 12 090-03809

ZUS Technical and Test Institute for Construction Prague
Prosečská 81/176a
190 00 Prague
Czech Republic
eota@zuz.cz

Member of **EOTA**
www.eota.eu

European Technical Assessment **ETA 17/0183** of 20/03/2017

Technical Assessment Body issuing the ETA: Technical and Test Institute for Construction Prague
Trade name of the construction product: Rawplug R-XPT Throughbolt
Product family to which the construction product belongs: Product area code: 33
Torque controlled expansion anchor for use in uncracked concrete
Manufacturer: Rawplug S.A.
Ul. Kwiczyńska 6
51-416 Wrocław
Poland
Manufacturing plant: Manufacturing Plant No 2
This European Technical Assessment contains: 10 pages including 8 Annexes which form an integral part of this assessment
This European Technical Assessment is issued in accordance with regulation (EU) No 305/2011, on the basis of: EAD 330232-00-0601

Translations of this European Technical Assessment in other languages shall fully correspond to the original issued document and should be identified as such.
Communication of this European Technical Assessment, including transmission by electronic means, shall be in full (excepted the confidential Annexes referred to above). However, partial reproduction may be made, with the written consent of the issuing Technical Assessment Body - Technical and Test Institute for Construction Prague. Any partial reproduction has to be identified as such.

ETA 17/0183 of 20/03/2017 - Page 1 of 10 090-03809

ZUS Technical and Test Institute for Construction Prague
Prosečská 81/176a
190 00 Prague
Czech Republic
eota@zuz.cz

Member of **EOTA**
www.eota.eu

European Technical Assessment **ETA 17/0782** of 21/09/2017

Technical Assessment Body issuing the ETA: Technical and Test Institute for Construction Prague
Trade name of the construction product: Rawl R-XP11-A4 Anchor
Product family to which the construction product belongs: Product area code: 33
Torque controlled expansion anchor for use in uncracked concrete
Manufacturer: Rawplug S.A.
Ul. Kwiczyńska 6
51-416 Wrocław
Poland
Manufacturing plant: Manufacturing Plant No 2
This European Technical Assessment contains: 10 pages including 8 Annexes which form an integral part of this assessment
This European Technical Assessment is issued in accordance with regulation (EU) No 305/2011, on the basis of: EAD 330232-00-0601
This version replaces: ETA 17/0782 issued on 20/06/2013

Translations of this European Technical Assessment in other languages shall fully correspond to the original issued document and should be identified as such.
Communication of this European Technical Assessment, including transmission by electronic means, shall be in full (excepted the confidential Annexes referred to above). However, partial reproduction may be made, with the written consent of the issuing Technical Assessment Body - Technical and Test Institute for Construction Prague. Any partial reproduction has to be identified as such.

ETA 17/0782 of 21/09/2017 - Page 1 of 10 090-03954

Instytut Techniki Budowlanej
ul. Piłsudskiego 26
00-475 Warszawa
t: (+48 22) 825-64-71
f: (+48 22) 825-76-55
fax: (+48 22) 825-50-86
www.itb.pl

Member of **EOTA**
www.eota.eu

European Technical Approval **ETA-13/0584**

English language translation - the original version is in Polish language

Name/ nazwa: R-CCA, R-CCA-A4 i R-CCJ Wedge Anchors / R-CCA, R-CCA-A4 and R-CCJ Wedge Anchors
Wskazalnik aprobaty / indicator of approval: RAWPLUG S.A. ul. Kwiczyńska 6 51-416 Wrocław Poland
Rodzaj i przeznaczenie wyrobu / rodzaj i przeznaczenie wyrobu: Stalowe kotwy rozporowe o kształcie trapezowym, w rozmiarach M8, M10, M12, M16 i M20, do zastosowań w konstrukcjach żelbetonowych i stalobetonowych w belce.
Termin ważności od dnia wydania / valid from the date of issue: 27. 06. 2013
Zakład produkcyjny / Manufacturing plant: Zakłady Produkcyjne nr 6 i 7
Wniosek Europejski / European Technical Approval contains: 13 stron, w tym 5 Załączników / 13 pages including 5 Annexes
Wniosek Europejski / European Technical Approval contains: ETA-130584 wydany od 19.06.2013 do 19.06.2018
ETA-130584 with validity from 19.06.2013 to 19.06.2018

EOTA Europejska Organizacja ds. Aprobacji Technicznych
European Organisation for Technical Approvals

Instytut Techniki Budowlanej
ul. Piłsudskiego 26
00-475 Warszawa
t: (+48 22) 825-64-71
f: (+48 22) 825-76-55
fax: (+48 22) 825-50-86
www.itb.pl

Member of **EOTA**
www.eota.eu

European Technical Assessment **ETA-11/0126** of 29/05/2017

General Part
Technical Assessment Body issuing the European Technical Assessment: Instytut Techniki Budowlanej
Trade name of the construction product: SafetyPlus
Product family to which the construction product belongs: Torque controlled expansion anchor of steel M8, M10, M12, M16 and M20 for use in non-cracked concrete
Manufacturer: RAWPLUG S.A.
ul. Kwiczyńska 6
51-416 Wrocław
Poland
Manufacturing plants: 1. Plant 2
2. Plant 3
This European Technical Assessment contains: 10 pages including 3 Annexes which form an integral part of this Assessment
This European Technical Assessment is issued in accordance with regulation (EU) No 305/2011, on the basis of: European Assessment Document (EAD) 330232-01-0601 "Mechanical fasteners for use in concrete"
This version replaces: ETA-11/0126 issued on 20/06/2013

EOTA Europejska Organizacja ds. Aprobacji Technicznych
European Organisation for Technical Approvals

Instytut Techniki Budowlanej
ul. Piłsudskiego 26
00-475 Warszawa
t: (+48 22) 825-64-71
f: (+48 22) 825-76-55
fax: (+48 22) 825-50-86
www.itb.pl

Member of **EOTA**
www.eota.eu

European Technical Assessment **ETA-17/0806** of 29/12/2017

General Part
Technical Assessment Body issuing the European Technical Assessment: Instytut Techniki Budowlanej
Trade name of the construction product: RLX
Product family to which the construction product belongs: Concrete Screw for use in cracked and non-cracked concrete
Manufacturer: RAWPLUG S.A.
ul. Kwiczyńska 6
51-416 Wrocław
Poland
Manufacturing plant: Manufacturing Plant no. 2
This European Technical Assessment contains: 18 pages including 3 Annexes which form an integral part of this assessment
This European Technical Assessment is issued in accordance with Regulation (EU) No 305/2011, on the basis of: European Assessment Document (EAD) 330232-00-0601 "Mechanical fasteners for use in concrete" and 330011-00-0601 "Adjustable concrete screw"
This version replaces: ETA-17/0806 issued on 27/06/2013

EOTA Europejska Organizacja ds. Aprobacji Technicznych
European Organisation for Technical Approvals

Instytut Techniki Budowlanej
ul. Piłsudskiego 26
00-475 Warszawa
t: (+48 22) 825-64-71
f: (+48 22) 825-76-55
fax: (+48 22) 825-50-86
www.itb.pl

Member of **EOTA**
www.eota.eu

European Technical Assessment **ETA-10/0655** of 19/08/2014

General Part
Technical Assessment Body issuing the European Technical Assessment: Instytut Techniki Budowlanej
Trade name of the construction product: R-RER / R-RO20, R-RER-W / R-RO20-W and R-RER-S / R-RO20-S
Product family to which the construction product belongs: Bonded anchor with anchor rod made of galvanized steel or stainless steel for use in cracked and non-cracked concrete
Manufacturer: RAWPLUG S.A.
ul. Kwiczyńska 6
51-416 Wrocław
Poland
Manufacturing plant: Manufacturing Plant no. 3
This European Technical Assessment contains: 18 pages including 3 Annexes which form an integral part of this Assessment
This European Technical Assessment is issued in accordance with Regulation (EU) No 305/2011, on the basis of: Guidelines for European Technical Approval (ETAG 021, Edition April 2013) "Metal anchors for use in concrete - Part 1: Anchors in general and Part 2: Bonded anchors" cited in European Assessment Document (EAD)
This version replaces: ETA-10/0655 issued on 27/06/2013

EOTA Europejska Organizacja ds. Aprobacji Technicznych
European Organisation for Technical Approvals

Instytut Techniki Budowlanej
ul. Piłsudskiego 26
00-475 Warszawa
t: (+48 22) 825-64-71
f: (+48 22) 825-76-55
fax: (+48 22) 825-50-86
www.itb.pl

Member of **EOTA**
www.eota.eu

European Technical Approval **ETA-10/0055**

English language translation - the original version is in Polish language

Name/ nazwa: R-RER / R-RO20, R-RER-W / R-RO20-W i R-RER-S / R-RO20-S
Wskazalnik aprobaty / indicator of approval: RAWPLUG S.A. ul. Kwiczyńska 6 51-416 Wrocław Poland
Rodzaj i przeznaczenie wyrobu / rodzaj i przeznaczenie wyrobu: Kotwy wbijane z prętem i średnicach M8 do M20 do wykonania zamocowań w belce.
Termin ważności od dnia wydania / valid from the date of issue: 27. 06. 2013
Zakład produkcyjny / Manufacturing plant: Zakład Produkcyjny nr 3
Wniosek Europejski / European Technical Approval contains: 25 stron, w tym 11 Załączników / 25 pages including 11 Annexes
Wniosek Europejski / European Technical Approval contains: ETA-100055 wydany od 28.08.2013 do 29.05.2018
ETA-100055 with validity from 28.08.2013 to 29.05.2018

EOTA Europejska Organizacja ds. Aprobacji Technicznych
European Organisation for Technical Approvals

Rawlplug Support

HDB approved supplier

HOUSING & DEVELOPMENT BOARD

Your Ref: Our Ref: **CRB/Anchor/RAWPLUG/000826C** Date: 08 May 2017

TEST REPORT

Subject: Determination of shear load on R-KEK-6-600-M12x190 Chemical Injection Anchor installed onto a concrete block.

Client: **Mr RAWLPLUG Singapore Pte Ltd**
 Bk 302, #04-11, 250 Loring Crescent
 Laying Offshore Supply Base,
 Singapore (06817)

Method of Test: Adopted ETAG 001

Description of Samples:

1. A set of five (05) R-KEK-6-600-M12x190 Chemical Injection anchors were tested for their shear load capacity.
2. All the M12 chemical injection anchors were installed onto a concrete block of grade 20 with dimensions 2.1m(L) x 0.55m(W) x 0.75m(H) cast on 27 Apr 17 by HDB Centre of Building Research.
3. All the test samples were as supplied by the Client.

Installation Procedures: All the test specimens were installed by the Client prior to the test.

Testing Procedures:

1. A shear force was applied to each specimen by means of a servo-hydraulic jack through a shear jig.
2. The relative displacement between anchor and concrete block were recorded.
3. The load was applied at a rate of 0.05mm/sec until failure occurred, and the test was terminated when the load dropped to approximately 50% of its ultimate value, or when the anchor shear off.
4. All the test data were automatically captured electronically.

Test Results:

1. The summary of test results and load-displacement relationships are as attached.

(Signed electronically) **STE Nor Rashid** Testing Officer *(Signed electronically)* **PE Winston Tuh** Laboratory Manager

This is a computer generated report which does not require signature. Page 1 of 3

HOUSING & DEVELOPMENT BOARD

Your Ref: Our Ref: **CRB/Anchor/RAWPLUG/000826C1** Date: 08 May 2017

TEST REPORT

Subject: Determination of tensile load on R-KEK-6-600-M12x190 Chemical Injection Anchor installed onto a concrete block.

Client: **Mr RAWLPLUG Singapore Pte Ltd**
 Bk 302, #04-11, 250 Loring Crescent
 Laying Offshore Supply Base,
 Singapore (06817)

Method of Test: Adopted ETAG 001

Description of Samples:

1. A set of five (05) R-KEK-6-600-M12x190 Chemical Injection anchors were tested for their tensile load capacity.
2. All the M12 chemical injection anchors were installed onto a concrete block of grade 20 with dimensions 4.05m(L) x 0.55m(W) x 0.26m(H) cast on 27 Apr 17 by HDB Centre of Building Research.
3. All the test samples were as supplied by the Client.

Installation Procedures: All the test specimens were installed by the Client prior to the test.

Testing Procedures:

1. An axial tensile force was applied to each specimen by means of a servo-hydraulic jack through a test jig.
2. A transducer measured the relative displacement between the anchor and concrete block with accuracy better than 0.001mm.
3. The load was applied at a rate of 0.05mm/sec until failure occurred, and the test was terminated when the load dropped to approximately 50% of its ultimate value.
4. All the test data were automatically captured electronically.

Test Results:

1. The summary of test results and load-displacement relationships are as attached.

(Signed electronically) **STE Nor Rashid** Testing Officer *(Signed electronically)* **PE Winston Tuh** Laboratory Manager

This is a computer generated report which does not require signature. Page 01/1

HOUSING & DEVELOPMENT BOARD

Your Ref: Our Ref: **CRB/Anchor/RAWPLUG/000826C2** Date: 08 May 2017

TEST REPORT

Subject: Determination of shear load on R-KEK-6-600-M16x230 Chemical Injection Anchor installed onto a concrete block.

Client: **Mr RAWLPLUG Singapore Pte Ltd**
 Bk 302, #04-11, 250 Loring Crescent
 Laying Offshore Supply Base,
 Singapore (06817)

Method of Test: Adopted ETAG 001

Description of Samples:

1. A set of five (05) R-KEK-6-600-M16x230 Chemical Injection anchors were tested for their shear load capacity.
2. All the M16 chemical injection anchors were installed onto a concrete block of grade 20 with dimensions 2.1m(L) x 0.55m(W) x 0.75m(H) cast on 27 Apr 17 by HDB Centre of Building Research.
3. All the test samples were as supplied by the Client.

Installation Procedures: All the test specimens were installed by the Client prior to the test.

Testing Procedures:

1. A shear force was applied to each specimen by means of a servo-hydraulic jack through a shear jig.
2. The relative displacement between anchor and concrete block were recorded.
3. The load was applied at a rate of 0.05mm/sec until failure occurred, and the test was terminated when the load dropped to approximately 50% of its ultimate value, or when the anchor shear off.
4. All the test data were automatically captured electronically.

Test Results:

1. The summary of test results and load-displacement relationships are as attached.

(Signed electronically) **STE Nor Rashid** Testing Officer *(Signed electronically)* **PE Winston Tuh** Laboratory Manager

This is a computer generated report which does not require signature. Page 1 of 3

HOUSING & DEVELOPMENT BOARD

Your Ref: Our Ref: **CRB/Anchor/RAWPLUG/000836B** Date: 18 May 2017

TEST REPORT

Subject: Determination of shear load on R-XPT-6-A4-M16x55 Medium Duty Mechanical Anchor installed onto a concrete block.

Client: **Mr RAWLPLUG Singapore Pte Ltd**
 Bk 302, #04-11, 250 Loring Crescent
 Laying Offshore Supply Base,
 Singapore (06817)

Method of Test: Adopted ETAG 001

Description of Samples:

1. A set of five (05) R-XPT-6-A4-M16x55 Medium Duty Mechanical anchors were tested for their shear load capacity.
2. All the M16 medium duty mechanical anchors were installed onto a concrete block of grade 20 with dimensions 2.1m(L) x 0.55m(W) x 0.75m(H) cast on 11 May 17 by HDB Centre of Building Research.
3. All the test samples were as supplied by the Client.

Installation Procedures: All the test specimens were installed by the Client prior to the test.

Testing Procedures:

1. A shear force was applied to each specimen by means of a servo-hydraulic jack through a shear jig.
2. The relative displacement between anchor and concrete block were recorded.
3. The load was applied at a rate of 0.05mm/sec until failure occurred, and the test was terminated when the load dropped to approximately 50% of its ultimate value, or when the anchor shear off.
4. All the test data were automatically captured electronically.

Test Results:

1. The summary of test results and load-displacement relationships are as attached.

(Signed electronically) **STE Nor Rashid** Testing Officer *(Signed electronically)* **PE Winston Tuh** Laboratory Manager

This is a computer generated report which does not require signature. Page 1 of 3

HOUSING & DEVELOPMENT BOARD

Your Ref: Our Ref: **CRB/Anchor/RAWPLUG/000836B1** Date: 18 May 2017

TEST REPORT

Subject: Determination of tensile load on R-XPT-6-A4-M16x55 Medium Duty Mechanical Anchor installed onto a concrete block.

Client: **Mr RAWLPLUG Singapore Pte Ltd**
 Bk 302, #04-11, 250 Loring Crescent
 Laying Offshore Supply Base,
 Singapore (06817)

Method of Test: Adopted ETAG 001

Description of Samples:

1. A set of five (05) R-XPT-6-A4-M16x55 Medium Duty Mechanical anchors were tested for their tensile load capacity.
2. All the M16 medium duty mechanical anchors were installed onto a concrete block of grade 20 with dimensions 4.05m(L) x 0.55m(W) x 0.26m(H) cast on 11 May 17 by HDB Centre of Building Research.
3. All the test samples were as supplied by the Client.

Installation Procedures: All the test specimens were installed by the Client prior to the test.

Testing Procedures:

1. An axial tensile force was applied to each specimen by means of a servo-hydraulic jack through a test jig.
2. A transducer measured the relative displacement between the anchor and concrete block with accuracy better than 0.001mm.
3. The load was applied at a rate of 0.05mm/sec until failure occurred, and the test was terminated when the load dropped to approximately 50% of its ultimate value.
4. All the test data were automatically captured electronically.

Test Results:

1. The summary of test results and load-displacement relationships are as attached.

(Signed electronically) **STE Nor Rashid** Testing Officer *(Signed electronically)* **PE Winston Tuh** Laboratory Manager

This is a computer generated report which does not require signature. Page 01/1

HOUSING & DEVELOPMENT BOARD

Your Ref: Our Ref: **CRB/Anchor/RAWPLUG/000836B2** Date: 18 May 2017

TEST REPORT

Subject: Determination of shear load on R-XPT-6-A4-M16x55 Medium Duty Mechanical Anchor installed onto a concrete block.

Client: **Mr RAWLPLUG Singapore Pte Ltd**
 Bk 302, #04-11, 250 Loring Crescent
 Laying Offshore Supply Base,
 Singapore (06817)

Method of Test: Adopted ETAG 001

Description of Samples:

1. A set of five (05) R-XPT-6-A4-M16x55 Medium Duty Mechanical anchors were tested for their shear load capacity.
2. All the M16 medium duty mechanical anchors were installed onto a concrete block of grade 20 with dimensions 2.1m(L) x 0.55m(W) x 0.75m(H) cast on 04 May 17 by HDB Centre of Building Research.
3. All the test samples were as supplied by the Client.

Installation Procedures: All the test specimens were installed by the Client prior to the test.

Testing Procedures:

1. A shear force was applied to each specimen by means of a servo-hydraulic jack through a shear jig.
2. The relative displacement between anchor and concrete block were recorded.
3. The load was applied at a rate of 0.05mm/sec until failure occurred, and the test was terminated when the load dropped to approximately 50% of its ultimate value, or when the anchor shear off.
4. All the test data were automatically captured electronically.

Test Results:

1. The summary of test results and load-displacement relationships are as attached.

(Signed electronically) **STE Nor Rashid** Testing Officer *(Signed electronically)* **PE Winston Tuh** Laboratory Manager

This is a computer generated report which does not require signature. Page 1 of 3

Test Report No. 7191144728 MEC16-SL
 issued 11 JAN 2017

SUBJECT:
 Load Test on Bonded & Mechanical Anchoring System

TESTED FOR:
 Rawlplug S.A.
 St. Antón de Tàrragona, 4
 E-43100 Vilanova i la Geltrú
 (Spain)

SAMPLE DESCRIPTION:

- Chemical with Threaded Rods
- Chemical with Reinforced Bar
- R-PTT Stud Anchor
- R-PTT Stud Anchor
- Concrete R-L-FF Sleeve Anchor
- R-PTT Stud Anchor
- R-PTT Stud Anchor

TEST METHOD:
 The test samples are fixed into a concrete block with a servo-hydraulic jack and failure to apply a pull-out force with the samples. The characteristic load for rupture and ultimate rupture is conducted after the usual inspection the mean ultimate load will be applied in the sample with similar inspection is conducted.

TUV SUD

(Signature)

Page 1 of 14

Rawlplug Support

Rawlplug Service

As a reliable producer we stand at our business partner's side and address their individual requirements with advice and actions. Therefore our customers may benefit from a complete range of services that we have developed for them:

- Global presence and active sales service in over 40 countries.
- Qualified, technical support and advice regarding economical fixing solutions, taking the latest building materials, standards and guidelines into account, including support on construction site.

- Training sessions in Rawlplug Academy.
- Convenient calculations with modern software.
- Marketing support.

Abovementioned services are parts of our Technical Development Services and Rawlplug Academy, important elements of the Rawlplug Offer. We provide our customers not only with modern products but also full technical backup, knowledge database and marketing and support. Below you may find a description of key services offered by Rawlplug to its customers.

Customer Service

Customer Service delivers individual customer solutions by providing professional consulting and expert advice to product- and application-specific questions, whether on the phone, via e-mail and fax:

- We will be happy to provide you with information on deliveries and on the availability of our products.
- Contact us if your tool needs repair or maintenance.
- Do you want to speak to your account manager on site? Do you have specific questions for our technical team? Customer Service representative will be pleased to help.

We look forward to your comments and will be pleased to respond to any questions or complaints you may have. This gives us the opportunity to consistently improve our service.



Software

User friendly programs offer easy and flexible way of designing and dimensioning fastening solutions. As a part of Rawlplug Technical Development Services they exceed international standards, fulfilling the requirements of users worldwide. Design and development has never been so easy!

The new modular structure of the program includes engineering software and special application modules. These features enable you to plan complete projects or individual applications in a structured and cost-effective way.

The software is written to international design standards, with multi language dictionary, and including national application documents, uses the existing commonly used forces (e.g. wind zones).

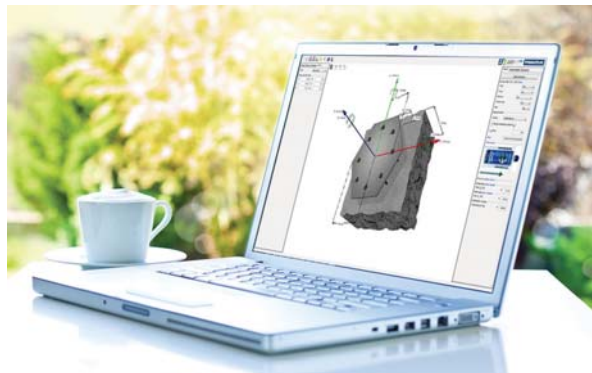

Rawlplug Support

Logistics

Our customers expect our products and services to meet the highest quality standards. We are aware that they expect the same from our logistics service.

Even though packaging and logistics may not seem to be particularly sophisticated areas, they require highly developed organizational culture, precision, punctuality, and use of advanced operating systems. Applying these rules enables us to deliver our client services at the highest level and guarantee successful delivery of any order. Regardless of the quantity, placement channel or collection way, we deliver your order on time and intact. We take care of your order no matter how big or small. Irrespective of which channel you use to place your order, we get the items to you in good time.



Technical Consulting

End users of our products have been in the centre of Rawlplug's business model ever since the company was established. This enables our organisation to understand how our products are used, use this insight to develop our products and deliver on our brand promise of premium quality.

Our Technical Sales Support offer:

- Technical advice and product recommendation.
- Support for engineers, consultants and craftsmen.
- Special solutions in the scope of fixing technology.
- Bespoke seminars for engineers, consultants, architects.
- Access to Rawlplug Academy extensive product training resource.



Marketing Support

It is part of our global business philosophy to build good partnerships and trading relationships with our Customers. Expanding and developing attributes to our core business philosophy include:

- Marketing support base:
 - In-house Marketing Team and Design Studio.
 - Technical support catalogues and product literature.
 - POS display, planogram and merchandising solutions tailored to your own needs.
 - Editorial & Press Support inclusive of a Product Library.
 - Guidebooks enabling creation of promotional activities using Rawlplug's products and corporate identity.

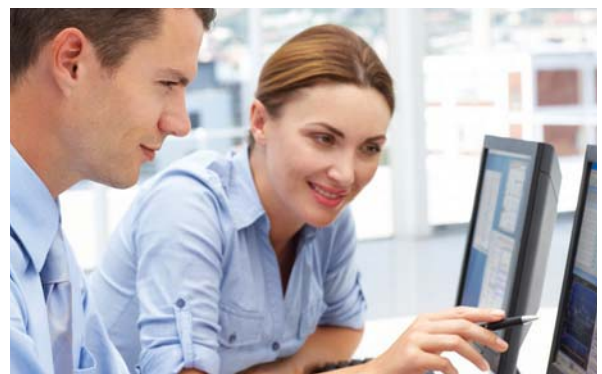

Application of anchors



Basics of anchoring - Loading considerations



Loads

▪ Static loads

The load is static if its value remains constant over time.

Static load examples:

- Dead weight – Constant load resulting from weight of construction element
- Permanent action resulting from element function
- Variable actions - For example snow or temperature loading

Static Load



▪ Oscillating loads

Variable loading with low amplitude and high frequency (e.g. engine vibrations)

▪ Dynamic load

Variable loading over time, with medium or high amplitude, with or without negative load (e.g. wind activity)

▪ Impact (shock) load

Load, often high, acting over a very short period of time

Dynamic/Shock/Oscillating Loads

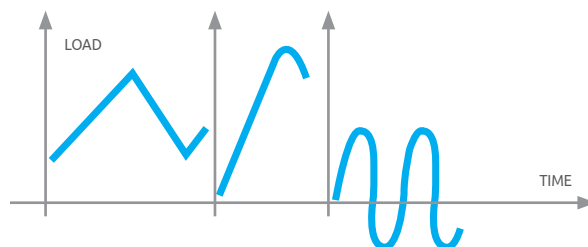

The four listed types of load may be either short or long term. Short-term loads may act once or repeatedly within a limited period of time. Long-term loads act on a permanent basis.

Loading directions:

1. Axial tensile load – Load application is in the direction of the connector axis, acting to pull the connector away from the substrate.
2. Axial compressive load – Load application is in the direction of the connector axis, acting to clamp the connector onto the substrate.
3. Shear (transverse) load – Loading direction is perpendicular to connector axis, with the load applied at the substrate surface (fixture tightened against the substrate).
4. Combined load (resultant) occurs when axial and shear loads are acting simultaneously.
5. Bending moment occurs when a shear load is applied offset from the substrate surface. Magnitude of bending moment is dependent on applied load and lever arm length.

Anchor design - Safety factor concepts

Two safety concepts can be applied in the design of anchorages:

- Global safety factor concept
- Partial safety factor concept (recommended for anchors with European Technical Approvals or Assessments (ETA)).



Basics of anchoring - Safety factor concepts

Global safety factor concept

Using the global safety factor concept, it must be proven that the recommended allowable load, F_{rec} of the anchor shall be greater than characteristic action F_{Sk}

$$F_{Sk} \leq F_{rec}$$

$$F_{rec} = \frac{F_{Rk}}{\gamma} [N]$$

F_{Rk} – characteristic resistance, γ – global safety factor

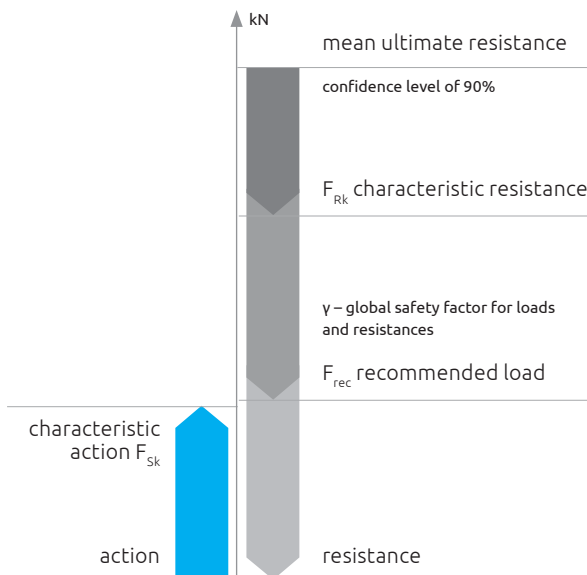

Partial safety factor concept

General principle:

Every potential failure mode should be considered, using appropriate partial safety factors for each. Loading in all directions must be calculated, ultimately taking the worst case scenario as being decisive.

Using the partial safety factor concept, it must be proven that the design resistance, F_{Rd} of the anchor shall be greater than design action, F_{Sd}

$$F_{Sd} \leq F_{Rd}$$

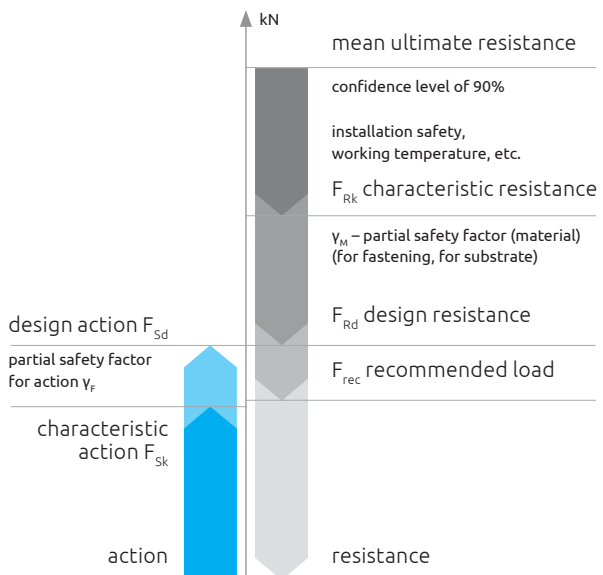

Design action:

$$F_{Sd} = F_{Sk} \cdot \gamma_f [N]$$

F_{Sk} – characteristic action, γ_f – partial safety factor for actions
 $\gamma_f = 1.35$ – for permanent actions, 1.50 – for variable actions.
 National regulations may be used.

Design resistance:

$$F_{Rd} = \frac{F_{Rk}}{\gamma_M} [N]$$

F_{Rk} – characteristic resistance
 γ_M – partial safety factor (material)

Calculation of partial safety factors

In case of concrete cone failure mode (according to ETAG 001 Annex C, 3rd Amendment August 2010):

$$\gamma_{Mc} = \gamma_c \cdot \gamma_2 [N]$$

γ_c – partial safety factor for concrete: $\gamma_c = 1.5$

γ_2 – partial safety factor accounting for the installation safety of an anchor system (determined from test results)

Tension loading

– for systems with high level of installation safety $\gamma_2 = 1.0$

– for systems with normal level of installation safety $\gamma_2 = 1.2$

– for systems with low, but still acceptable level of installation safety $\gamma_2 = 1.4$

Shear loading (pry-out failure and concrete edge failure) $\gamma_2 = 1.0$

Basics of anchoring - Safety factors & calculations

In case of steel failure: v_{Ms}

Tensile load:

$$v_{Ms} = \frac{1.2}{F_{yk}/F_{uk}}$$

Shear loading with and without lever arm:

If $f_{uk} \leq 800 \text{ N/mm}^2$ and $f_{yk}/f_{uk} \leq 0.8$

$$v_{Ms} = \frac{1.0}{F_{yk}/F_{uk}} \geq 1.25$$

If $f_{uk} > 800 \text{ N/mm}^2$ or $f_{yk}/f_{uk} > 0.8$

$$v_{Ms} = 1.5$$

If $v_{Ms} > 1.5$ it shall be assumed that

$$v_{Ms} = 1.5$$

Calculation of design resistance:

In case of concrete cone, pull out and concrete pry-out failure:

Tensile force

$$N_{Rd} = \frac{N_{Rk}}{v_{Mc}} \text{ [N]}$$

Shear force:

$$V_{Rd} = \frac{V_{Rk}}{v_{Mc}} \text{ [N]}$$

Combined force:

$$\left(\frac{N_{Sd}}{N_{Rd}}\right)^{1.5} + \left(\frac{V_{Sd}}{V_{Rd}}\right)^{1.5} \leq 1$$

In case of steel failure:

Tensile force

$$N_{Rd,s} = \frac{N_{Rk,s}}{v_{Ms}} \text{ [N]}$$

Shear force:

$$V_{Rd,s} = \frac{V_{Rk,s}}{v_{Ms}} \text{ [N]}$$

Combined force:

$$\left(\frac{N_{Sd}}{N_{Rd,s}}\right)^{2.0} + \left(\frac{V_{Sd}}{V_{Rd,s}}\right)^{2.0} \leq 1$$

Characteristic resistance (load bearing capacity)

Characteristic resistance of an anchor, in any direction, with regard to concrete cone failure is calculated from a mean ultimate failure load for an individual anchor not influenced by edge distances and spacing effects. This characteristic resistance corresponds to the 5% fractile of ultimate loads, calculated according to statistical procedures for a confidence level of 90%.

$$F_{Rk} = (1 - k \cdot v) \cdot F_{Rk,m} \text{ [N]}$$

The calculation depends on the number of tests (influencing the k factor) and the coefficient of variation (v). In cases where the number of tests is higher than 40 anchors, $k = 2$ can be assumed.

Calculation of characteristic resistance in the case of steel failure:

Characteristic resistance of steel for tension:

$$N_{Rk,s} = A_s \cdot f_{uk} \text{ [N]}$$

Characteristic resistance of steel for shear:

$$V_{Rk,s} = 0.5 \cdot A_s \cdot f_{uk} \text{ [N]}$$

A_s – cross-sectional area [mm²], f_{uk} – nominal tensile strength [MPa]

Note: For anchors with a sleeve, A_s is based on the diameter of the sleeve, as it is assumed that the load bearing capacity of the bolt and sleeve are combined.

Recommended loads

For the concept of global safety factors:

$$F_{Sk} \leq \frac{F_{Rk}}{v} \text{ [N]}$$

For the concept of partial safety factors:

Recommended load can be calculated from: $F_{Sd} \leq F_{Rd}$:

$$F_{Sd} = F_{Sk} \cdot v_F \leq F_{Rd}$$

$$F_{Sk} = \frac{F_{Rk}}{v_F \cdot v_M} \text{ [N]}$$

Thus F_{Sk} based on the concept of global safety factor and the above inequality:

$$F_{Sk} \leq F_{rec} = \frac{F_{Rk}}{v_F \cdot v_M} \text{ [N]}$$

F_{rec} load is, therefore, calculated based on characteristic resistance F_{Rk} divided by two partial safety factors v_F and v_M , assumed for the anchor's load and material, respectively. Thus $v = v_F \cdot v_M$

Basics of anchoring - Materials

The base material/substrate

Consideration of the base material (and its associated properties) is critical in the selection of an anchor or connector technology. It is therefore important to correctly define the material in order to ensure correct anchor installation without substrate damage, as well as safe and reliable subsequent performance under load.

Concrete



concrete

Concrete, in its standard form, is a compound of cement, aggregates and water. It usually possesses high compressive strength, while tensile strength is comparatively low.



cracked concrete

Lightweight concrete is another derivative, in which case heavy aggregate is replaced by light additives like pumice, slag or Styrofoam. Due to the lower compressive strength of these materials, lightweight concrete shows lower strength parameters in general when compared to plain concrete.

This document presents anchor performance data for the following concrete grades: C20/25, C30/37, C40/50 and C50/60 (according to ENV 206 standard). In this

format, the values before and after the oblique signify characteristic compressive strengths measured for cylinders (150mm diameter, 300mm height) and cubes (150mm edge), respectively.

The table below lists concrete compressive strengths traditionally applied in different countries.

As a measure to increase the low tensile strength of concrete, steel reinforcing elements (bars, mesh, etc.) may be cast into the concrete member. Their function is to withstand tensile loads within the structure, which may otherwise lead to extensive crack formation within the tensile zone. Reinforcement does not guarantee elimination of cracking in this so-called crack zone. It does, however, limit the size of cracks significantly, ultimately leading to an admissible crack size of no greater than 0.3 mm. Cracks usually assume a wedge form, terminating in the region of the neutral axis within the concrete structure cross-section.

Products approved for use in cracked concrete:

R-HPTII-A4, R-HPTII-ZF, R-SPLII, R-DCA, R-DCL, R-RBL, R-RBP, R-KER II, R-KER, R-KEX II, R-SPLII, R-LX.

Grade CE	Characteristic compressive strength F_{ck} (cylinder)	Characteristic compressive strength F_{ck} (cube)	Great Britain	Germany	France	Poland
			Mean compressive strength, tested (150mm cube)	Mean compressive strength, tested (200mm cube)	Mean resistance, tested (cylinder 16x32cm)	PN-B-03264:2002
C12/15	12	15	20	19	17	B15
C16/20	16	20	25	24	21	B20
C20/25	20	25	30	29	25	B25
C25/30	25	30	35	33	30	B30
C30/37	30	37	42	40	35	B37
C35/45	35	45	50	48	40	B45
C40/50	40	50	55	54	45	B50
C45/55	45	55	60	57	50	B55
C50/60	50	60	65	62	55	B60

Masonry

Masonry walls are multi-layer substrates consisting of blocks of heterogeneous material, built in to the desired structure using mortar.

The compressive strength of the block material is usually higher than that of the mortar. Thus the connectors should, as a rule, be installed within the body of the block.

Blocks may take several forms:

- Solid blocks with compact structure. Blocks of various dimensions, without internal cavities, made from ceramic
- (ceramic or clinker bricks) or sand-lime (silica) materials. These possess relatively high compressive strength.
- Hollow blocks with compact structure. Blocks of various dimensions and shapes, with several internal cavities. Blocks possess reasonably low compressive strength, despite being made from relatively high compressive strength materials (ceramic or silica).
- Solid blocks with porous structure. Blocks of various dimensions, without internal cavities but with high concentrations of pores or inclusions of other materials. Examples include aerated concrete or solid blocks of lightweight concrete. Materials of this category possess low compressive strengths.

Basics of anchoring - Materials

- Hollow blocks with porous structure. Similarly to solid porous blocks these elements have low compressive strength, weakened further by internal cavities. In most cases these blocks are made from lightweight concrete.

Products with Approval for masonry and hollow walls:

R-KEM II and RM50



solid brick
(ceramic or silica)

lightweight concrete

hollow brick

hollow block

Anchor material

Steel

Durability characteristics of screws and bolts are determined by appropriate mechanical property classes from 3.6 to 12.9.

This classification system consists of two numbers separated with a dot, e.g.:

5.6

The first number corresponds to the value of $0.01 R_m$ of the finished part in MPa. The second number determines the value of 0.1 of R_e/R_m percentage ratio, as follows:

$$R_m = 500 \text{ MPa} \quad | \quad R_e/R_m = 60\% \quad | \quad R_e = 300 \text{ MPa}$$

The strength classes of nuts are marked 4, 5, 6, 7, 8, 10 & 12 which corresponds with the value of 0.01 of R_m of nut steel in MPa.

Nut classes shall correspond to screw or bolt classes; therefore, for class 5.6 screws or bolts, class 5 (or greater) nuts shall be used.



Anchor spacing and edge distances

Due to the expansion forces induced by the functioning of anchorage connections, the following parameters shall be taken into account while determining load bearing capacity for a particular product:

- thickness of base material (determined by fixing's effective embedment depth h_{ef})

- spacing of anchored joints (s)
- distance of connections from the edge (c_1, c_2) and corners (c_3) of the base material.

Overlapping of tension cones of neighbouring anchorages in concrete reduces the load bearing capacity of such fasteners.

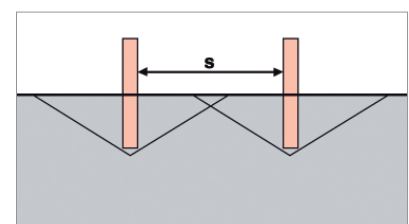
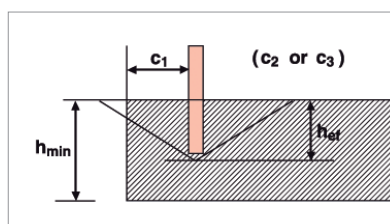
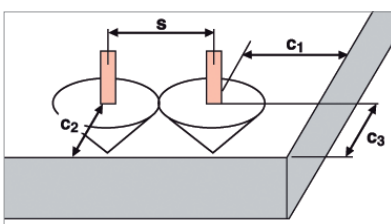

Basics of anchoring - Spacing & edge distances

Reduction of anchor spacing and edge distances

In some cases the anchor spacing and distance from edges and corners can be reduced. Such a reduction will impact the anchor's load bearing capacity and, in order to account for the impact, one or more reduction factors will have to be applied.

Effective embedment of fixing h_{ef}

For each connection the minimum fixing depth is determined, which ensures safe load resistance. Some types of anchors can be fixed at greater depth, which increases the load bearing capability (R-SPL, in particular). For more information, please contact RAWLPLUG® technical consultant.

Reduction factors related to the anchor spacing: f_s



Reduction factor related to the distance c_N of the anchor from the edge, in cases where load is not being applied towards a free edge: f_{c_N}



Reduction factor related to the distance c_V of the anchor from the edge, in cases where load is being applied towards a free edge: f_{c_V}

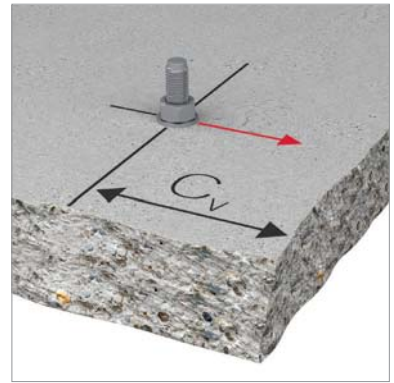

Reduction factor related to the distance $c_{cr,sp}$ of the anchor from a corner: $f_{c_{cr,sp}}$



In case of a group of anchors, it is necessary to consider the connection which is located in the most unfavourable place.



tensile



shear

Reduced design resistance of anchor

$$F_{Rd,red} = F_{Rd} \cdot f_s \cdot f_{c_N} \cdot f_{c_V}$$

$$F_{Rd,red} \geq F_{Sd}$$

F_{Rd} – design resistance according to the technical data tables herein,
 f_s, f_{c_N}, f_{c_V} – reduction factors of axial spacing of anchors and distance to the edge of the base material.

Basics of anchoring - Anchor installation

Drilling

The method of drilling a hole for the installation of an anchor depends on the type of substrate material. There are drilling techniques:

- rotary drilling – drilling by rotation and without percussion (or hammer action), recommended for drilling in materials of low mechanical strength such as bricks & aerated concrete due to the fact that it does not enlarge the hole, nor damage the structure of the material;

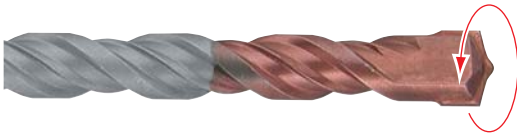

- percussive drilling – drilling by rotation with multiple light strikes with the drill bit into the substrate; recommended for drilling materials with high mechanical strength and solid structure such as concrete & solid brick;

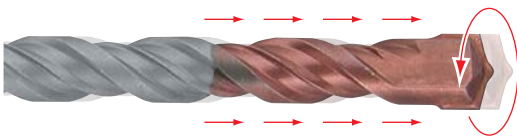

- hammer drilling – drilling by rotation with a small number of high energy strikes with the drill bit into the substrate; recommended for drilling in extremely hard structures such as concrete;

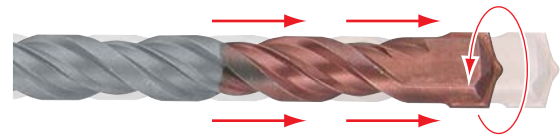

A drill bit is a tool, which is subject to wear – its degree and frequency is a derivative of the hardness of the substrate material. The harder the substrate, the greater the wear of the drill bit. Be sure to monitor wear and replace the drill bit whenever necessary.

In the process of drilling a hole for embedding an anchor it is important to be aware of and achieve the correct diameter and depth of the hole.

After the drilling is finished it is essential to clear the hole of dust and drill debris. Failure to do this can be the cause of improper anchoring of the fastener in the substrate.



Anchor installation methods:

1. Push-through installation – convenient and time-efficient method, which allows user to drill and install directly through the fixture without marking out hole locations and pre-positioning anchors. If the fixture is pre-drilled then it may be used as a drilling template, before the anchors are installed directly through the clearance holes. RAWLPLUG® R-XPT, R-XPTII and R-HPTII throughbolt families are all examples of push-through fixings.
2. Pre-positioning installation – this method requires the installation of the anchors in the base material, before the fixture is moved into place. In this case the anchor diameter

and the drill hole diameter are different. Our RAWLBOLT (R-RBP) and all bonded anchors are examples of products that require pre-positioning.

3. Stand-off installation – attachment of the fixture at an offset distance from the surface of the base material. One common offset application is the use of internally threaded anchors with long rods, studs or bolts. The anchor is installed in the base material before assembling with threaded rod or bolt. The RAWLPLUG® internally threaded wedge anchors - R-DCA, R-DCA-A4 & R-DCL - may be used for stand-off applications.

Basics of anchoring - Torque & bending moments

Tightening torque

When using expanding anchors, it is necessary to apply a required tightening torque of the magnitude given herein, in order to ensure optimal expansion and achieve the load-bearing capacities given in tables in the next chapter (we recommend using a calibrated torque wrench). Torque transmits to a pre-tensioning force, influencing the initial expansion of the anchor. Moreover, the tightening torque applied will clamp the fixed element to the base material.

The values of tightening torque given in the specification and design guide should not be exceeded.

After initial application of the tightening torque, relaxation occurs causing a reduction in tension and therefore clamping force.

All data related to a load bearing capacity given in the present specification and design guide account for this torque relaxation behaviour.

Bending moment

In the case of some applications, anchored connections are subject to the influence of bending moments. Generally, this applies when fixed elements are offset from the base material. Applied load is, as a result, not purely in the shear direction - significant tension is also present. It is necessary to ensure the bending moment induced by such loads is not higher than allowable bending moment (given for each type and diameter of anchor).

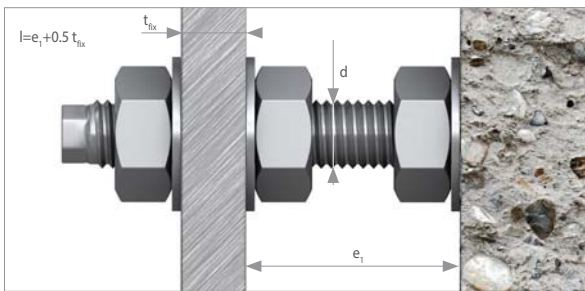

with clamping to the base material

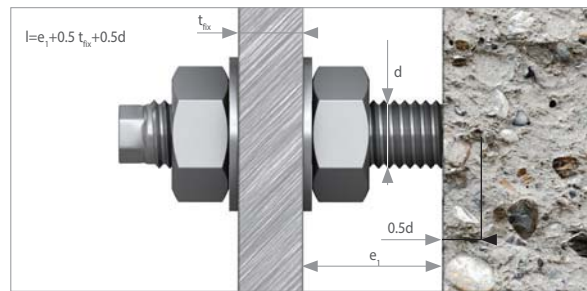

without clamping to the base material

$$M_V = V \times \frac{l}{\alpha_M} \text{ [Nm]}$$

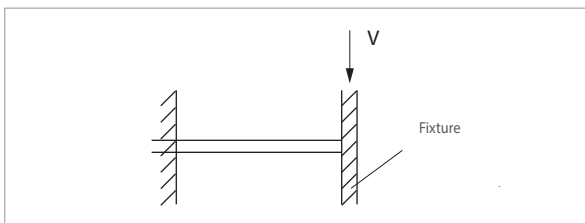

$\alpha_M = 1.0$ when element (fixture) is not fixed and can rotate freely

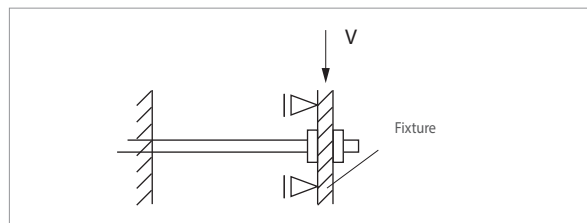

$\alpha_M = 2.0$ when element (fixture) is fixed and cannot rotate

Installation of anchors

Installation guidelines are attached to all packaging for our anchors. We recommend strict adherence to all of the instructions contained therein. Debris and dust must always be removed from the hole before the anchor is installed in

order to avoid risk of limiting the anchorage depth. Hole cleaning is particularly important for bonded anchors, because any debris or dust will decrease the load bearing capacity of the anchorage.

Basics of anchoring - Rebar connections

Post-installed rebar connections

Using chemical resin, rebar can be post-installed in concrete to act as structural reinforcement or, alternatively, to create an anchorage. The role depends on the application, installation type and also the feasibility of use of a specified resin.

RAWLPLUG® offer resin products that can provide a solution in both scenarios.



Rebar installed with chemical resin as an anchor

In many applications rebar installed with chemical resin must be designed to act as an anchorage. This scenario may arise for a number of reasons: the rebar may not be carrying the full tensile load as it would in structural reinforcement (i.e. the concrete must resist an element of the tensile loading), there may be an absence of existing cast-in reinforcement (i.e. no overlap splice to take up tensile loads), or the rebar anchorage may be subject to shear loading.

The characteristic failure mode for this type of anchorage - similarly to chemical anchors using threaded rods - is concrete cone failure, or a combination of concrete cone failure

and pull-out. It is therefore important to keep appropriate spacing and edge distances.

Embedment depths are generally smaller, compared with cases of rebar acting as structural reinforcement. They can, however, vary and for some types of RAWLPLUG® resins deeper embedments can be employed, facilitating higher performance.

Depending on the type of resin, various diameters of rebar and grades of steel can be applied.

Rebar installed with chemical resin as structural reinforcement

Introduction

Both for new reinforced concrete construction requiring connection with an existing structure, and for the reinforcement, modernisation or upgrading of an existing structure, there can be a requirement to create permanent connections between new and existing construction elements. In these applications post-installed rebar connections are very useful. The aforementioned scenarios can arise when joining slabs,

beams and columns, reinforcing nodes, walls and when building balconies and cantilevers.

Depending on the type of existing construction and its reinforcement, two different types of connections can be described - anchorage (Figure 1.1), and overlap splice with existing construction rebar (Figure 1.2)

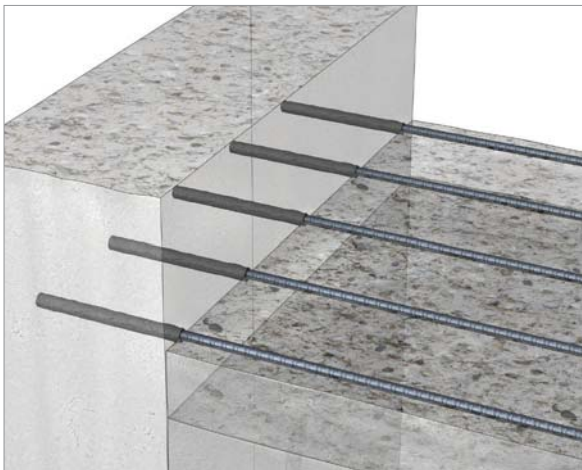

Figure 1.1: Anchorage

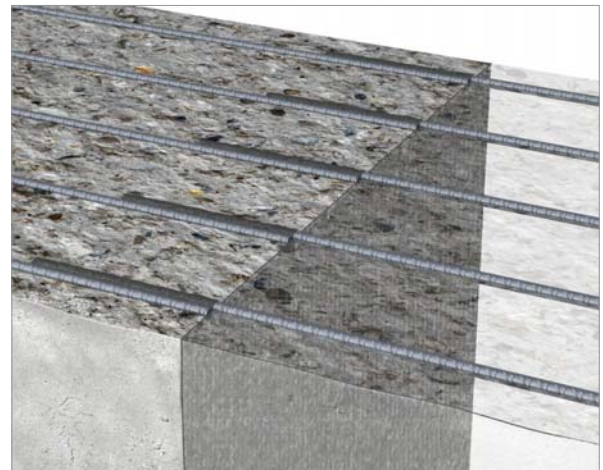

Figure 1.2: Overlap splice

Basics of anchoring - Rebar connections

Various applications (Figures 1-5) are covered by Technical Report TR 023 "Assessment of post-installed rebar connections", which, alongside European standard Eurocode 2 "Design of concrete structures" Part 1-1 "General rules and rules for buildings", is a fundamental

document for the design and testing of these types of anchorages.

Figures 1-5 (below) show applications in which resins with rebar can be used successfully.

Examples of post-installed rebar applications

Figure 1

Overlap joint for rebar connections of slabs and beams

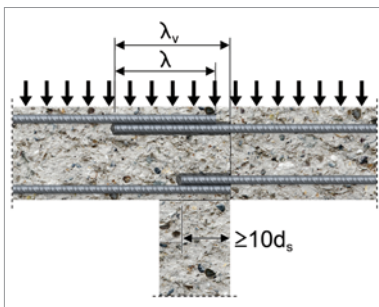

Figure 2

Overlap joint at a foundation of a column or wall where the rebars are stressed in tension

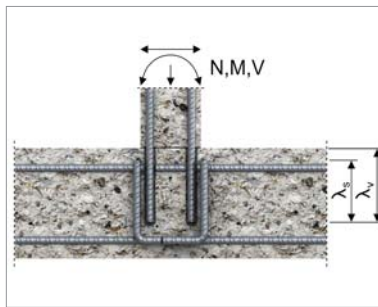

Figure 3

End anchoring of slabs or beams designed as simply supported

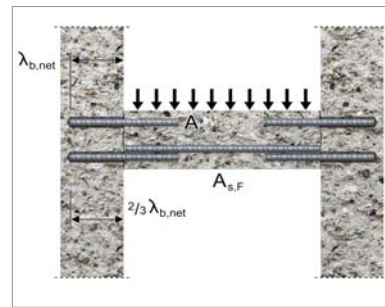

Figure 4

Rebar connection for components stressed primarily in compression. The rebars are stressed in compression

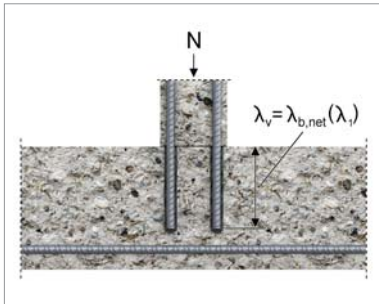
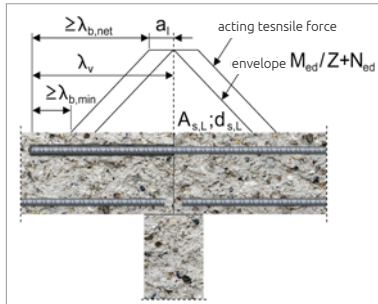

Figure 5

Anchoring of reinforcement to cover the line of acting tensile force.



Note to Figure 1-5

In the figures transverse reinforcement is not shown, however, the transverse reinforcement as required by EC2 shall be present.

The shear transfer between old and new concrete shall be designed according to EC2.

Rebars

Rebars are key elements of reinforced concrete constructions. Their role is to bear tension loads due to the fact that concrete possesses high compressive strength but very low tensile strength.

In the applications previously described, depending on construction type and implementation, rebars can form either an overlap splice effect, where new bars will extend the effect of existing rebar, or an anchorage.

In the case of post-installed rebar, loads are transferred into the concrete via the adhesion of the resin, which simultaneously dovetails with the ribs of the rebar (equivalent to the effect at the rebar-concrete interface in cast-in rebar solutions). The resin reacts like compressive struts at an angle of 45° in a strut-and-tie model.

Cooperation between bars in overlap splice is possible because of load transference between them based on a 45° truss model. Similarly to the above scenario, resin and concrete act as compressive struts.

One possible failure mode in the case of post-installed rebar is pull out failure, when resin wedges are sheared causing the rebar to act like a smooth bar (performance is determined only by friction and adhesion, as the dovetailing effect is eliminated). Another is concrete splitting failure caused by naturally occurring cracks, which run from the rebar ribs in the direction of the concrete surface. Consequently, it is important to ensure correct concrete cover and rebar spacing.

Basics of anchoring - Rebar connections

Resin characteristics

Load bearing capacity is determined by adhesion forces at the rebar-resin and resin-concrete interfaces, as well as the strength characteristics of the steel elements used. Of subsequent importance is the resin bond strength, which should be equal to or greater in strength than the concrete. Accordingly, to permit the use of a given resin in the applications described previously, it needs to be tested according to TR 023 "Assessment of post-installed rebar connections" to obtain Technical Approval. TR 023 covers post-installed rebar connections designed in accordance with the EN standard Eurocode 2 "Design of concrete structures", Part 1-1 "General rules and rules for buildings", on the assumption that only tension loads can be transferred, shear loads are not considered and transverse reinforcement should be designed in addition, based on Eurocode 2. The base material is non-carbonated concrete of class C12/15 – C50/60. Post-installed rebar are straight reinforcing bar with properties according to Eurocode 2, Annex C, with classes B and C recommended. The Technical

Report does not cover fire resistance, fatigue, dynamic or seismic loading of post-installed rebar connection.

Among others, tests include: tests for bond resistance in C20/25 and C50/60, installation safety tests in dry and wet concrete, functioning under sustained loads, functioning under freeze/thaw conditions, installation at maximum embedment depth, and correct injection. Proof is required that post-installed rebar connections function like cast-in rebar – with comparable load transference and displacement behaviour.

This is demonstrated by achieving appropriate bond resistance f_{bd} , compared with cast-in rebar bond strength. The necessary bond resistance for connections designed according to Eurocode 2 for different concrete classes is shown in Figure 6. For resins having a bond resistance smaller than that assumed, values based on testing and decreased according to levels from TR 023 should be included in the technical approval.

Figure 6: Design according to EC2 without limitation

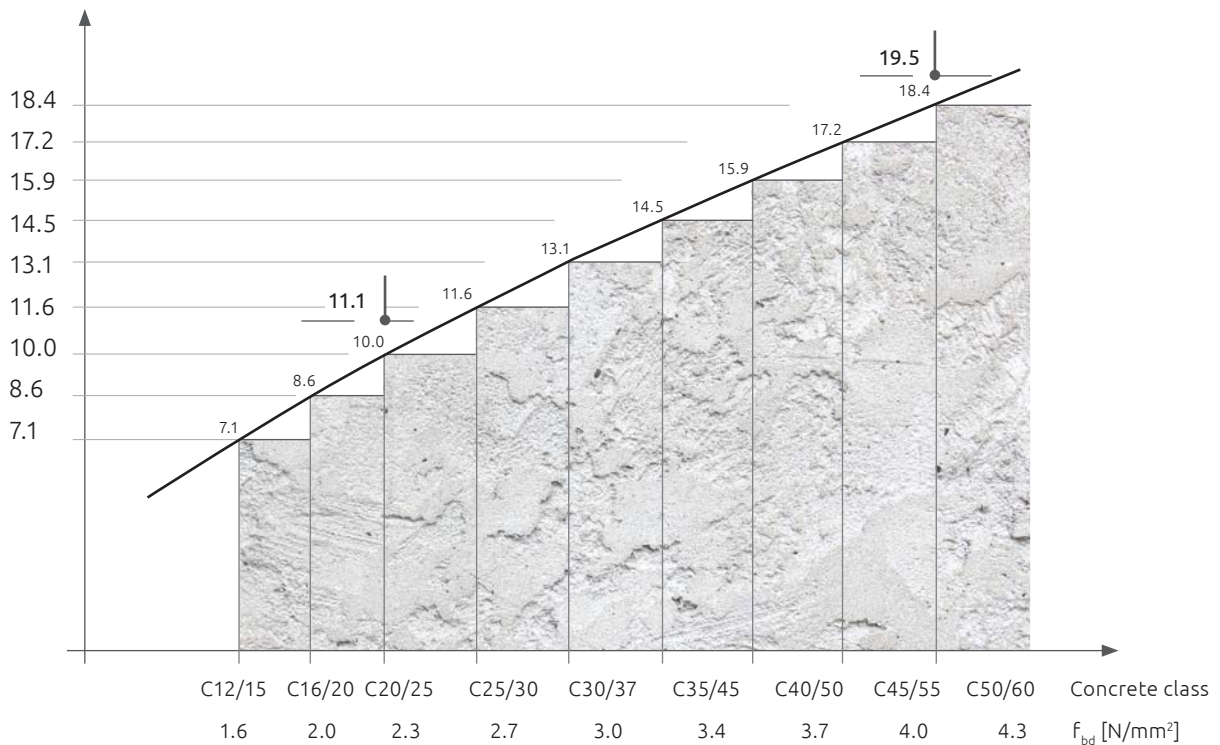

Basics of anchoring - Rebar connections

Design of anchorage and splice overlap connections

Connections should be designed in accordance with obligatory rules for the design of reinforced concrete structures, taking into account the load distribution on the construction and its nodes. It is very important to determine and factor in the existing reinforcement layout.

Technical Approvals, obtained based on Technical Report TR 023, and Eurocode 2, Part 1-1 are the primary reference documents for determining internal load distribution in sections and for the design of these types of connections.

An approval contains bond resistance values depending on concrete class and rebar diameter, data for concrete cover, minimum and maximum embedment depth and lap splice, as well as general rules for rebar arrangement.

Meanwhile Eurocode 2 covers the design of reinforced concrete structures, facilitating determination of internal load distribution and calculation of embedment depth or overlap splice, taking into account factors such as: bond conditions, rebar shape, concrete cover and transverse reinforcement.

The first value calculated in the design process, according to Eurocode 2, is basic anchorage length:

$$l_{b,reqd} = \left(\frac{\sigma_{sd}}{f_{bd}}\right) \cdot \left(\frac{\sigma_{sd}}{f_{bd}}\right)$$

where:

σ_{sd} – design stress of the bar

f_{bd} – design value of the ultimate bond resistance according to corresponding ETA

Design anchorage length for anchorages

The next value to consider is the design anchorage length calculated as follows.

$$l_{bd} = \alpha_1 \alpha_2 \alpha_3 \alpha_4 \alpha_5 l_{b,reqd}$$

α_1 – coefficients acc. to EC2, Tab. 8.2

α_2 – effect of the form of the bars assuming adequate cover (1.0 for straight bar in tension and in compression)

α_3 – effect of concrete minimum cover (acc. to EC2, Figure 8.3)

$$0.7 \leq \alpha_2 \leq 1.00$$

$$\alpha_2 = 1 - 0.15 \frac{c_d - \varnothing}{\varnothing} \text{ – rebar in tension}$$

$$\alpha_2 = 1.0 \text{ – rebar in compression}$$

$$c_d = \min \{0.5a; c_i; c\} \text{ – for straight bars (acc. to EC2, Figure 8.3)}$$

α_3 – the effect of confinement by transverse reinforcement not welded to main reinforcement

$\alpha_3 = 1.0$ when no transverse reinforcement or no influence

$$0.7 \leq \alpha_3 \leq 1.00$$

$$\alpha_3 = 1 - K \times \lambda \text{ – rebar in tension}$$

$$\alpha_3 = 1.0 \text{ – rebar in compression}$$

$$K \text{ – values for beams and slabs acc. to EC2, Figure 8.4}$$

$$\lambda = \frac{\sum A_{st} - \sum A_{st,min}}{A_s}$$

$\sum A_{st}$ – cross-sectional area of the transverse reinforcement along the design anchorage length l_{bd}

$\sum A_{st,min}$ – cross-sectional area of the minimum transverse reinforcement

A_s – area of a single anchored bar with maximum bar diameter

α_4 – influence of one or more welded transverse bars along the design anchorage length,

$\alpha_4 = 1.0$ when no transverse reinforcement or no influence

α_5 – the effect of the pressure transverse to the plane of splitting along the design anchorage length

$$0.7 \leq \alpha_5 \leq 1.0$$

$$\alpha_5 = 1 - 0.04 \rho \text{ (only rebar in tension)}$$

ρ – transverse pressure at ultimate limit state along l_{bd}

Product of $\alpha_4 \alpha_5$ must fulfil: $\alpha_4 \alpha_5 \geq 0.7$

Design anchorage length must be in the range between minimum and maximum anchorage length:

$$l_{b,min} \leq l_{bd} \leq l_{b,max}$$

$l_{b,min}$ – minimum anchorage length

$l_{b,min} = \max \{0.3l_{b,reqd}; 10\varnothing; 100 \text{ mm}\}$ – rebar in tension

$l_{b,min} = \max \{0.6l_{b,reqd}; 10\varnothing; 100 \text{ mm}\}$ – rebar in compression

$l_{b,max}$ = maximum embedment depth, from ETA

Basics of anchoring - Rebar connections

Design embedment length for overlap splice

$$l_o = \alpha_1 \alpha_2 \alpha_3 \alpha_5 \alpha_6 l_{b,reqd}$$

$\alpha_1 - \alpha_5$ - as above
 α_6 - influence of overlap splice relative to the total cross-section area

$$\alpha_6 = \sqrt{\frac{\rho_l}{25}} \quad 1.0 \leq \alpha_6 \leq 1.5$$

ρ_l - percentage of reinforcement lapped within $0.65 l_o$ from the centre of the lap length considered, acc. to EC2, Tab.8.3
 Design lap splice length must be in the range between minimum and maximum lap splice length:

$$l_{o,min} \leq l_o \leq l_{v,max} - c_1$$

$l_{o,min}$ - minimum lap splice length
 $l_{o,min} = \max \{0.3 \alpha_6 l_{b,reqd}; 15\emptyset; 200 \text{ mm}\}$
 $l_{v,max}$ - maximum embedment depth, from ETA
 c_1 - concrete cover at frontal concrete surface

Embedment depth for lap splice connections:

$$l_v \geq l_o + c_1$$

- The clear distance between lapped bars should not be greater than $4\emptyset$, or else the lap length should be increased by a length equal to the difference between the clear space and $4\emptyset$
- Minimum concrete cover is stated in appropriate ETA, whilst minimum cover should also be kept acc. to EC2, chapter 4.4.1.2

- Transverse reinforcement should be designed acc. to EC2, chapter 8.7.4
- Connections between existing and new concrete should be designed according to EC2
- Minimum clear spacing between bars is kept according to ETA requirements

Connections between existing and new concrete

Connections between existing and new concrete should be designed according to EC2.

The surface of the joint should be prepared, for example roughened to expose aggregate. If the surface of the existing concrete is carbonated, the layer should be removed in the area of the new reinforcing bar prior to installation.

The above directions may be disregarded in cases where building components are new, not carbonated and the environment conforms to dry condition criteria.

Design process using RAWLPLUG® EasyFix software

The EasyFix program functions as a helpful tool in the design of post-installed rebar connections, both in cases of chemical anchoring and structural reinforcement. The program includes a Calculator for calculation and selection of anchors, a Resin Consumption Calculator for chemical resins and a Post-Installed Connection module for anchorage and lap splices, for use in both new and existing structures.

Anchor design software - EasyFix II

It is with pleasure that we present an improved and updated version of our popular anchor design software EasyFix. EasyFix II is more intuitive and enables a simplified and faster anchor selection process for specialised constructions, providing different variants of anchors depending on the fixture geometry.

Main features of EasyFix II:

1. Enter different base plate geometries.
2. Attach a variety of different sections to the base element.
3. Add eccentricity to the anchorage by moving the point where the applied loads are acting to any point on the base element.
4. Design stand off applications by offsetting the base element from the surface of the substrate.
5. Make use of slotted holes to increase performance by preventing shear forces acting on anchors close to an edge.
6. Input data through a simple graphical user interface.

7. Enter loads using characteristic or design values.
8. Pre-filter results by anchor group, anchor material and diameter.
9. View the load distribution across the anchorage and the percentage of capacity utilized by each anchor.

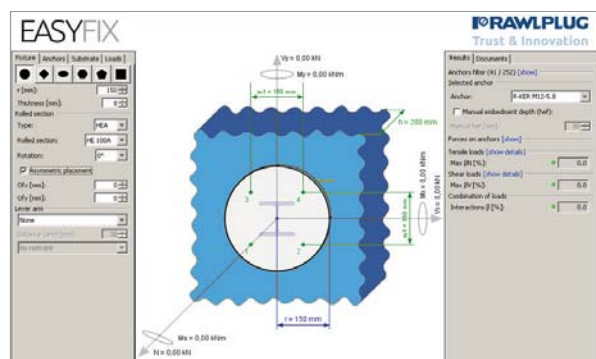

Choose baseplate shape (circular)

Basics of anchoring - Design software

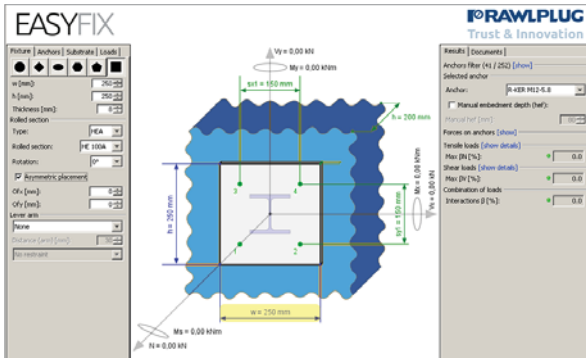

Choose baseplate shape (square/rectangular)

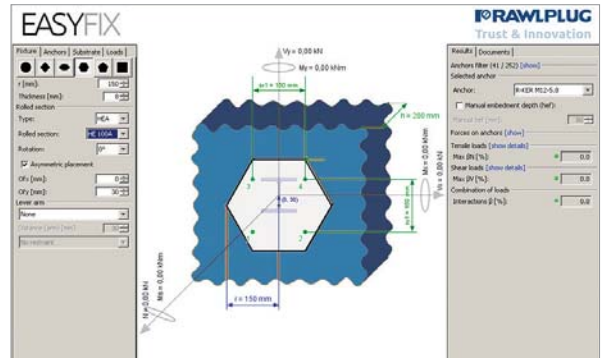

Asymmetric loading - default position is center of baseplate

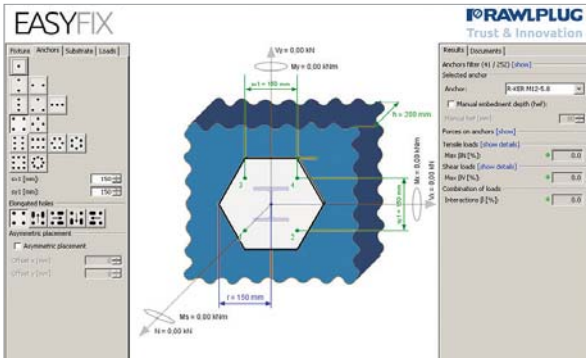

Choose hole positions and quantity (rectangular pattern)

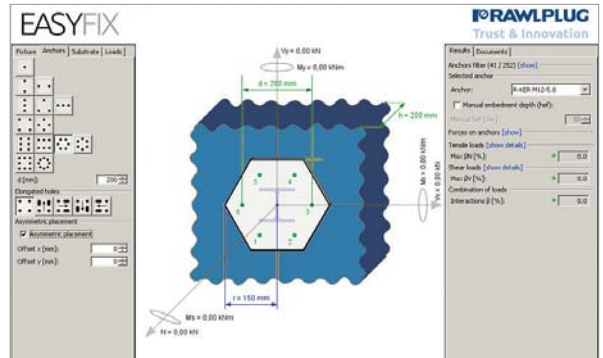

Choose hole positions and quantity (circular pattern)

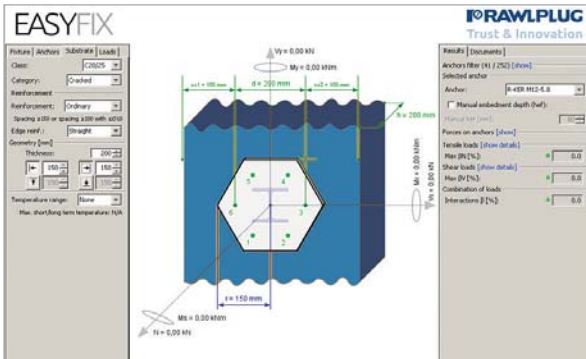

Add concrete edges and substrate details

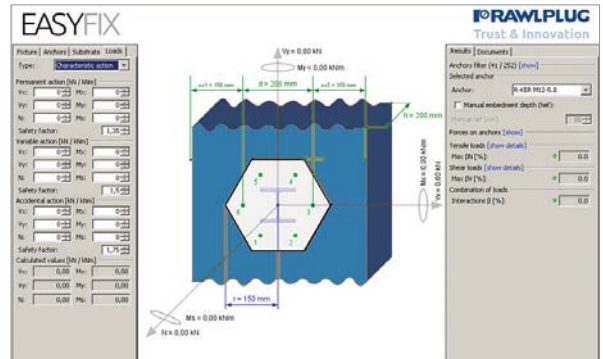

Add loads by characteristic action

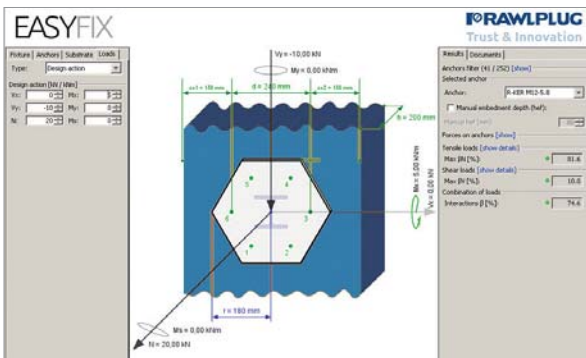

Alternatively add loads by design action

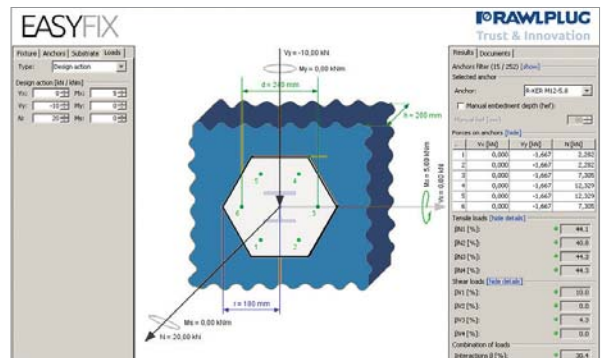

Calculates and displays suitable anchors

Basics of anchoring - Terminology & symbols

The notations and symbols frequently used in the catalogue are given below. Further notations are given in the text.

Approved Body Symbols

	European Technical Approval (ETA)
	CE Marking (conformity with ETA or harmonised standard)
	Polish Construction Sign (Poland, Warsaw)
	Resistance to Fire Exposure
	Factory Mutual Research Corporation (FM) Approved
	Earthquake resistant
	Prüfgemeinschaft Mauerbahrer (PGM) SicherSafe Certifikat

Indices

c	Concrete
cp	Concrete pry-out
d	Design value
k	Characteristic value
M	Material
p	Pull-out
R	Resistance
s	Steel
S	Action
sp	Splitting
u	Ultimate
y	Yield

Loads

N	Normal force (positive: tension load, negative: compression load)
N_{Rk}	Characteristic value of resistance of a single anchor or an anchor group (tension load)
$N_{Rk,p}$	Characteristic resistance in case of failure by pull-out (tension load)
$N_{Rk,c}$	Characteristic resistance in case of concrete cone failure (tension load)
$N_{Rk,s}$	Characteristic resistance of an anchor in case of steel failure (tension load)
N_{Rd}	Design value of resistance of a single anchor or an anchor group (tension load)
$N_{Rd,p}$	Design resistance of an anchor in case of failure by pull-out (tension load)
$N_{Rd,c}$	Design resistance for an anchor or an group of anchors in the case of concrete cone failure (tension load)
$N_{Rd,s}$	Design resistance of an anchor in case of steel failure (tension load)
V	Shear force
V_{Rk}	Characteristic resistance of a single anchor or an anchor group (shear load)
$V_{Rk,c}$	Characteristic resistance in case of concrete edge failure (shear load)
$V_{Rk,cp}$	Characteristic resistance in case of failure by pry-out (shear load)
$V_{Rk,s}$	Characteristic resistance in case of steel failure (shear load)
V_{Rd}	Design resistance of a single anchor or an anchor group (shear load)
$V_{Rd,c}$	Design resistance in case of concrete edge failure (shear load)
$V_{Rd,cp}$	Design resistance of an anchor in case of failure by pry-out (shear load)
$V_{Rd,s}$	Design resistance in case of steel failure (shear load)

Safety factors

V_{Mc}	Partial safety factor for concrete cone failure
V_{Ms}	Partial safety factor for steel failure

Concrete and steel (mechanical properties)

f_{yk}	Characteristic steel yield strength (nominal value)
f_{uk}	Characteristic steel ultimate tensile strength (nominal value)
A_s	Stressed cross-sectional area of steel
W_{el}	Elastic section modulus calculated from the stressed cross-sectional area of steel
$M_{Rk,s}^0$	Characteristic bending resistance of an individual anchor
M	Allowable bending moment

Characteristic values of anchors

c	Edge distance
c_N	Edge distance (tensile resistance)
c_V	Edge distance (shear resistance)
c_{cr}	Edge distance for ensuring the transmission of the characteristic resistance
$c_{cr,N}$	Edge distance for ensuring the transmission of the characteristic tensile resistance of a single anchor without spacing and edge effects.
$c_{cr,V}$	Edge distance for ensuring the transmission of the characteristic shear resistance of a single anchor without spacing and edge effects.
c_{min}	Minimum allowable edge distance
d	Diameter of anchor bolt or thread diameter
d_f	Drill hole diameter in fixture
d_0	Drill hole diameter in substrate
h	Thickness of substrate
h_{min}	Minimum thickness of substrate
h_{ef}	Effective anchorage depth
h_{nom}	Embedment depth
h_0	Minimum drilled hole depth
k	Factor to be taken from the relevant ETA (pry-out failure)
L	Anchor length
s	Spacing of anchors in a group
s_{cr}	Spacing for ensuring the transmission of the characteristic resistance
s_{min}	Minimum allowable spacing
$s_{cr,N}$	Spacing for ensuring the transmission of the characteristic tensile resistance of a single anchor without spacing and edge effects.
t_{fx}	Fixture thickness
T_{inst}	Installation torque



Bonded Anchors

The following section provides detailed information and technical data on the range of Rawlplug® Bonded Anchors.

The range includes:
Bonded Anchors in Cartridges | CFS+ Cartridge Free System
Glass Capsules | Accessories

BONDED ANCHORS IN CARTRIDGES

- R-KEX II
 - with Threaded Rods
 - with Sockets
 - with Rebar as an Anchor
 - with Post-Installed Rebar
- R-KER II
 - with Threaded Rods
 - with Sockets
 - with Rebar as an Anchor
 - with Post-Installed Rebar
- R-KER
 - with Threaded Rods
 - with Sockets
 - with Rebar as an Anchor
 - with Post-Installed Rebar
- R-KEM II
 - with Threaded Rods for Concrete
 - with Threaded Rods for Masonry
- R-KF2
 - with Threaded Rods



Effortless extrusion with manual or pneumatic dispenser guns

Peel-back label with additional info

Applications, benefits and substrates

R-KEX II with Threaded Rods

Premium pure epoxy resin approved for use in cracked and non-cracked concrete



Installation movie



Approvals and Reports

- ETA-13/0455



Product overview

Features and benefits

- Approved for use with threaded rods for use in cracked and non-cracked concrete (EAD 330499-00-0601)
- Suitable for use in dry and wet substrates including under water
- Very high chemical resistance – suitable for applications exposed to influence of various agents (industrial or marine environment)
- Minimal shrinkage provides the option to use in diamond drilled holes and over-sized holes.
- Extended bonding time ensures easy installation of metal components (up to 35 min in +20°C)
- For use in temperatures above 0°C
- Seismic category C1
- Diamond and hammer drilling
- Special mixer nozzle - allows for precise mixing of the product

Applications

- Safety barriers
- Formworks support systems
- Structural steelwork
- Street lamps
- Curtain walling
- Racking systems
- Balustrading
- Barriers
- Cladding restraints
- Masonry support
- Machinery
- Platforms

Base materials

Approved for use in:

- Cracked concrete C20/25-C50/60
- Non-cracked concrete C20/25-C50/60

Installation guide

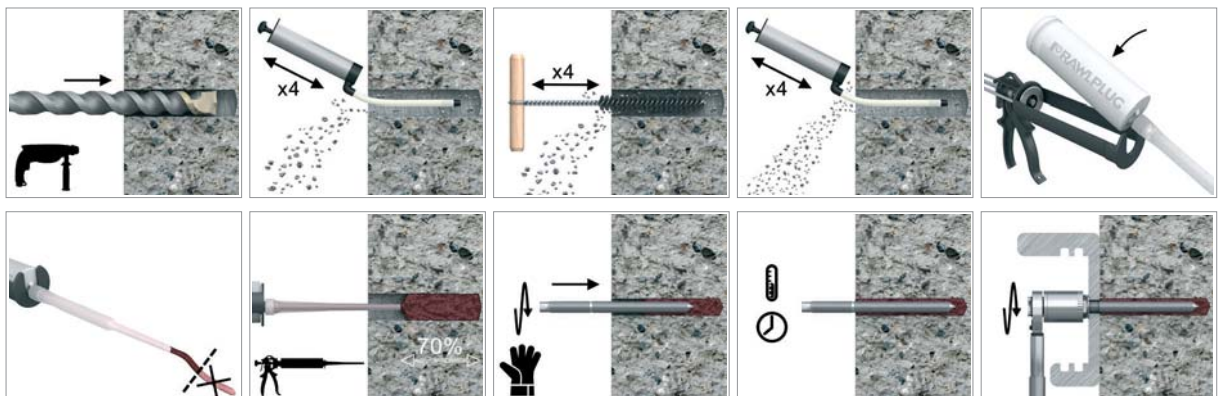

Installation guide (cont.)

1. Drill hole to the required diameter and depth for stud size being used.
2. Clean the drill hole thoroughly with brush and hand pump at least four times before installation.
3. Attach nozzle and insert cartridge into gun.
4. Dispense to waste until even colour is obtained.
5. Insert the mixer nozzle to the bottom of the drill hole and inject resin, slowly withdrawing the nozzle as the hole is filled to 70% of its depth.
6. Immediately insert the stud, slowly and with slight twisting motion. Remove any excess resin around the hole before it sets and leave it undisturbed until the curing time elapses.
7. Attach fixture and tighten the nut to the required torque.

Product information

Product Code	Resin	Description / Resin Type	Volume
			[ml]
R-KEX-II-385	R-KEX II	Epoxy Resin	385
R-KEX-II-600	R-KEX II	Epoxy Resin	600

R-STUDS

Size	Product Code			Anchor		Fixture		
	Steel class 5.8	Steel class 8.8	Steel grade A4	Diameter	Length	Hole diameter	Max. thickness	
				d	L	d _f	t _{fix} for h _{ef,min}	t _{fix} for h _{ef,max}
				[mm]	[mm]	[mm]	[mm]	[mm]
M8	R-STUDS-08110	R-STUDS-08110-88	R-STUDS-08110-A4	8	110	9	40	-
	R-STUDS-08160	-	R-STUDS-08160-A4*	8	160	9	90	-
M10	R-STUDS-10130	R-STUDS-10130-88	R-STUDS-10130-A4	10	130	12	48	-
	R-STUDS-10170	-	R-STUDS-10170-A4*	10	170	12	88	-
	R-STUDS-10190	-	R-STUDS-10190-A4*	10	190	12	108	-
M12	R-STUDS-12160	R-STUDS-12160-88	R-STUDS-12160-A4	12	160	14	65	-
	R-STUDS-12190	-	R-STUDS-12190-A4*	12	190	14	95	-
	R-STUDS-12220	-	R-STUDS-12220-A4*	12	220	14	125	-
	R-STUDS-12260	-	R-STUDS-12260-A4*	12	260	14	165	-
	R-STUDS-12300	-	R-STUDS-12300-A4*	12	300	14	205	45
M16	R-STUDS-16190	R-STUDS-16190-88	R-STUDS-16190-A4	16	190	18	71	-
	R-STUDS-16220	R-STUDS-16220-88	R-STUDS-16220-A4*	16	220	18	101	-
	R-STUDS-16260	-	R-STUDS-16260-A4*	16	260	18	141	-
	R-STUDS-16300	-	R-STUDS-16300-A4*	16	300	18	181	-
	R-STUDS-16380	-	R-STUDS-16380-A4*	16	380	18	261	41
M20	R-STUDS-20260	R-STUDS-20260-88	R-STUDS-20260-A4	20	260	22	117	-
	R-STUDS-20300	R-STUDS-20300-88	R-STUDS-20300-A4*	20	300	22	157	-
	R-STUDS-20350	-	R-STUDS-20350-A4*	20	350	22	207	-
M24	R-STUDS-24300	R-STUDS-24300-88	R-STUDS-24300-A4*	24	300	26	132	-
M30	R-STUDS-30380	R-STUDS-30380-88	R-STUDS-30380-A4	30	380	32	181	-

* Make to order

Installation data

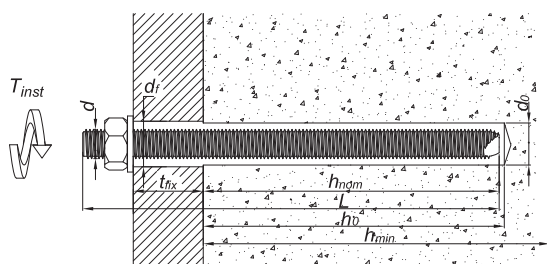

All products listed in this publication are branded and distributed with RAWLPLUG® or RAWL® trademarks.

Installation data (cont.)

R-STUDS

Size			M8	M10	M12	M16	M20	M24	M30
Thread diameter	d	[mm]	8	10	12	16	20	24	30
Hole diameter in substrate	d ₀	[mm]	10	12	14	18	24	28	35
Hole diameter in fixture	d _f	[mm]	9	12	14	18	22	26	32
Min. hole depth in substrate	h ₀	[mm]	h _{nom} + 5						
Min. substrate thickness	h _{min}	[mm]	h _{nom} + 30 mm; ≥ 100 mm			h _{nom} + 2d ₀			
Installation torque	T _{inst}	[Nm]	10	20	40	80	120	180	200
Min. spacing	s _{min}	[mm]	40	40	40	50	60	70	85
Min. edge distance	c _{min}	[mm]	40	40	40	50	60	70	83
MINIMUM EMBEDMENT DEPTH									
Installation depth	h _{nom,min}	[mm]	60	70	80	100	120	140	165
MAXIMUM EMBEDMENT DEPTH									
Installation depth	h _{nom,max}	[mm]	160	200	240	320	400	480	600

Minimum working and curing time

Resin temperature	Concrete temperature	Working time	Curing time*
[°C]	[°C]	[min]	[min]
5	5	150	2880
10	10	120	1080
20	20	35	480
25	30	12	300

* For wet concrete the curing time must be doubled

Mechanical properties

R-STUDS

Size			M8	M10	M12	M16	M20	M24	M30
R-STUDS METRIC THREADED RODS - steel class 5.8									
Nominal ultimate tensile strength - tension	F _{uk}	[N/mm ²]	500	500	500	500	500	500	500
Nominal yield strength - tension	F _{yk}	[N/mm ²]	400	400	400	400	400	400	400
Cross sectional area - tension	A _s	[mm ²]	36.6	58	84.3	157	245	352.8	559.8
Elastic section modulus	W _{el}	[mm ³]	31.2	62.3	109.2	277.5	541	935	1868
Characteristic bending resistance	M ⁰ _{Rk,s}	[Nm]	19	37	65	166	324	561	1124
Design bending resistance	M	[Nm]	15	30	52	133	259	449	899
Allowable bending resistance	M _{rec}	[Nm]	11	21	37	95	185	321	642
R-STUDS METRIC THREADED RODS - steel class 8.8									
Nominal ultimate tensile strength - tension	F _{uk}	[N/mm ²]	800	800	800	800	800	800	800
Nominal yield strength - tension	F _{yk}	[N/mm ²]	640	640	640	640	640	640	640
Cross sectional area - tension	A _s	[mm ²]	36.6	58	84.3	157	245	352.8	559.8
Elastic section modulus	W _{el}	[mm ³]	31.2	62.3	109.2	277.5	541	935	1868
Characteristic bending resistance	M ⁰ _{Rk,s}	[Nm]	30	60	105	266	519	898	1799
Design bending resistance	M	[Nm]	24	48	84	213	416	718	1439
Allowable bending resistance	M _{rec}	[Nm]	17	34	60	152	297	513	1028
R-STUDS METRIC THREADED RODS - A4									
Nominal ultimate tensile strength - tension	F _{uk}	[N/mm ²]	700	700	700	700	700	700	700
Nominal yield strength - tension	F _{yk}	[N/mm ²]	350	350	350	350	350	350	350
Cross sectional area - tension	A _s	[mm ²]	36.6	58	84.3	157	245	352.8	559.8
Elastic section modulus	W _{el}	[mm ³]	31.2	62.3	109.2	277.5	541	935	1868
Characteristic bending resistance	M ⁰ _{Rk,s}	[Nm]	26	52	92	233	454	786	1574
Design bending resistance	M	[Nm]	17	34	59	149	291	504	1009
Allowable bending resistance	M _{rec}	[Nm]	12	24	42	107	208	360	721

Basic performance data

R-STUDS

Performance data for single anchor without influence of edge distance and spacing

Size		M8	M10	M12	M16	M20	M24	M30	M8	M10	M12	M16	M20	M24	M30
Substrate		Non-cracked concrete							Cracked concrete						
CHARACTERISTIC LOAD															
TENSION LOAD $N_{Ru,m}$															
R-STUDS METRIC THREADED RODS - STEEL CLASS 5.8															
Minimum embedment depth	[kN]	18	29	36	51	66	84	107	12	18	21	35	47	60	76
Maximum embedment depth	[kN]	18	29	42	78	122	176	280	18	29	42	78	122	176	280
R-STUDS METRIC THREADED RODS - STEEL CLASS 8.8															
Minimum embedment depth	[kN]	24	30	36	51	66	84	107	12	18	21	35	47	60	76
Maximum embedment depth	[kN]	29	46	67	126	196	282	449	29	46	63	113	176	217	283
R-STUDS METRIC THREADED RODS - A4-70															
Minimum embedment depth	[kN]	24	30	36	51	66	84	107	12	18	21	35	47	60	76
Maximum embedment depth	[kN]	26	41	59	110	171	247	393	26	41	59	110	171	217	283
SHEAR LOAD $V_{Ru,m}$															
R-STUDS METRIC THREADED RODS - STEEL CLASS 5.8															
Minimum embedment depth	[kN]	9	14	21	39	61	88	140	9	14	21	39	61	88	140
Maximum embedment depth	[kN]	9	14	21	39	61	88	140	9	14	21	39	61	88	140
R-STUDS METRIC THREADED RODS - STEEL CLASS 8.8															
Minimum embedment depth	[kN]	15	23	34	63	98	141	214	15	23	34	63	95	119	153
Maximum embedment depth	[kN]	15	23	34	63	98	141	224	15	23	34	63	98	141	224
R-STUDS METRIC THREADED RODS - A4-70															
Minimum embedment depth	[kN]	13	20	29	55	86	124	196	13	20	29	55	86	119	153
Maximum embedment depth	[kN]	13	20	29	55	86	124	196	13	20	29	55	86	124	196
DESIGN LOAD															
TENSION LOAD N_{Rk}															
R-STUDS METRIC THREADED RODS - STEEL CLASS 5.8															
Minimum embedment depth	[kN]	12	19	24	34	44	56	71	8	12	14	24	32	40	51
Maximum embedment depth	[kN]	12	19	28	52	81	117	187	12	19	28	52	81	117	187
R-STUDS METRIC THREADED RODS - STEEL CLASS 8.8															
Minimum embedment depth	[kN]	16	20	24	34	44	56	71	8	12	14	24	32	40	51
Maximum embedment depth	[kN]	19	31	45	84	131	188	299	19	31	42	75	117	145	189
R-STUDS METRIC THREADED RODS - A4-70															
Minimum embedment depth	[kN]	14	20	24	34	44	56	71	8	12	14	24	32	40	51
Maximum embedment depth	[kN]	14	22	32	59	91	132	210	14	22	32	59	91	132	189
SHEAR LOAD $V_{Ru,m}$															
R-STUDS METRIC THREADED RODS - STEEL CLASS 5.8															
Minimum embedment depth	[kN]	7	11	17	31	49	70	112	7	11	17	31	49	70	102
Maximum embedment depth	[kN]	7	11	17	31	49	70	112	7	11	17	31	49	70	112
R-STUDS METRIC THREADED RODS - STEEL CLASS 8.8															
Minimum embedment depth	[kN]	12	18	27	50	78	112	143	12	18	27	47	63	80	102
Maximum embedment depth	[kN]	19	31	45	84	131	188	299	19	31	42	75	117	145	189
R-STUDS METRIC THREADED RODS - A4-70															
Minimum embedment depth	[kN]	8	13	19	35	55	80	126	8	13	19	35	55	80	102
Maximum embedment depth	[kN]	8	13	19	35	55	80	126	8	13	19	35	55	80	126

Basic performance data (cont.)

R-STUDS

Performance data for single anchor without influence of edge distance and spacing

Size		M8	M10	M12	M16	M20	M24	M30	M8	M10	M12	M16	M20	M24	M30
Substrate		Non-cracked concrete						Cracked concrete							
RECOMMENDED LOAD															
TENSION LOAD N_{Rk}															
R-STUDS METRIC THREADED RODS - STEEL CLASS 5.8															
Minimum embedment depth	[kN]	9	14	17	24	32	40	51	6	8	10	17	23	28	36
Maximum embedment depth	[kN]	9	14	20	37	58	84	133	9	14	20	37	58	84	133
R-STUDS METRIC THREADED RODS - STEEL CLASS 8.8															
Minimum embedment depth	[kN]	11	14	17	24	32	40	51	6	8	10	17	23	28	36
Maximum embedment depth	[kN]	14	22	32	60	93	134	214	14	22	30	54	84	103	135
R-STUDS METRIC THREADED RODS - A4-70															
Minimum embedment depth	[kN]	10	14	17	24	32	40	51	6	8	10	17	23	28	36
Maximum embedment depth	[kN]	10	16	23	42	65	94	150	10	16	23	42	65	94	135
SHEAR LOAD $V_{Rd,m}$															
R-STUDS METRIC THREADED RODS - STEEL CLASS 5.8															
Minimum embedment depth	[kN]	5	8	12	22	35	50	80	5	8	12	22	35	50	73
Maximum embedment depth	[kN]	5	8	12	22	35	50	80	5	8	12	22	35	50	80
R-STUDS METRIC THREADED RODS - STEEL CLASS 8.8															
Minimum embedment depth	[kN]	9	13	19	36	56	80	102	9	13	19	34	45	57	73
Maximum embedment depth	[kN]	9	13	19	36	56	81	128	9	13	19	36	56	81	128
R-STUDS METRIC THREADED RODS - A4-70															
Minimum embedment depth	[kN]	6	9	13	25	39	57	90	6	9	13	25	39	57	73
Maximum embedment depth	[kN]	6	9	13	25	39	57	90	6	9	13	25	39	57	90

Product commercial data

Product Code	Volume [ml]	Quantity [pcs]			Weight [kg]			Bar Code	Shelf Life [month]
		Box	Outer	Pallet	Box	Outer	Pallet		
R-KEX-II-385	385	10	10	560	6.7	6.7	390.0	5906675028538	20
R-KEX-II-600	600	7	7	441	7.0	7.0	472.7	5906675293721	20

R-KEX II with Sockets

Premium pure epoxy resin approved for use with internally threaded sockets



Approvals and Reports

- ETA-13/0455



Product overview

Features and benefits

- Allows removal of bolt to leave a re-usable socket in place
- Approved for use with Sockets in non-cracked concrete EAD 330499-00-0601
- Suitable for use in dry and wet substrates including under water
- Very high chemical resistance – suitable for applications exposed to influence of various agents (industrial or marine environment)
- Minimal shrinkage provides the option to use
- Extended bonding time ensures easy installation of metal components (up to 30 min in +20°C)
- For use in temperatures above 0°C
- Special mixer nozzle - allows for precise mixing of the product

Applications

- Safety barriers
- Temporary works/formworks support systems
- Balustrading
- Barriers
- Cladding restraints
- Masonry support
- Machinery
- Platforms
- Steelwork

Base materials

- Approved for use in:
- Non-cracked concrete C20/25-C50/60

Installation guide

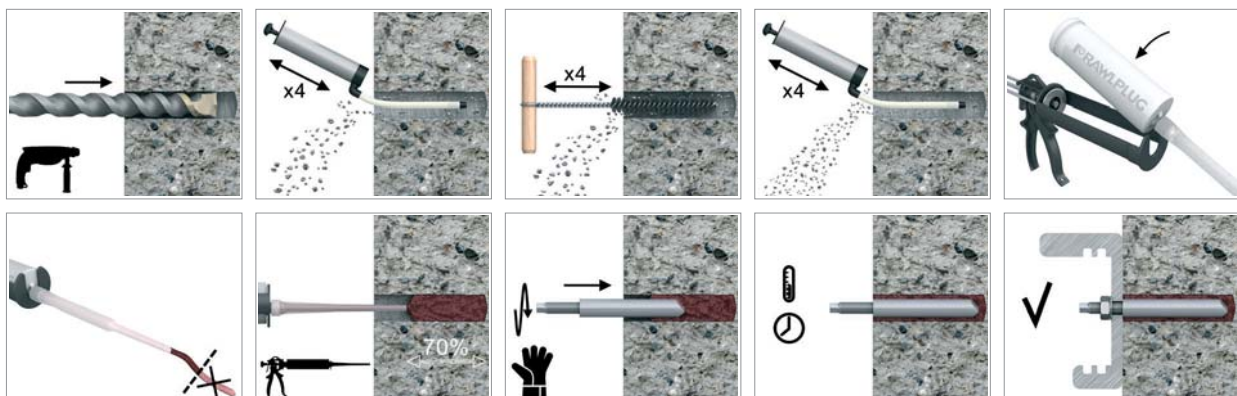

All products listed in this publication are branded and distributed with RAWLPLUG® or RAWL® trademarks.

Installation guide (cont.)

1. Drill hole to the required diameter and depth for socket size being used.
2. Clean the drill hole thoroughly with brush and hand pump at least four times before installation.
3. Attach nozzle and insert cartridge into gun.
4. Dispense to waste until even colour is obtained.
5. Insert the mixer nozzle to the bottom of the drill hole and inject resin, slowly withdrawing the nozzle as the hole is filled to 70% of its depth.
6. Immediately insert the socket, slowly and with slight twisting motion. Remove any excess resin around the hole before it sets and leave it undisturbed until the curing time elapses.
7. Attach fixture and tighten the bolt to the required torque.

Product information

Product Code	Resin	Description / Resin Type	Volume
			[ml]
R-KEX-II-385	R-KEX II	Epoxy Resin	385
R-KEX-II-600	R-KEX II	Epoxy Resin	600

SOCKETS

Size	Product Code		Anchor			Fixture
	Steel class 5.8	Steel grade A4	Socket diameter	Length	Internal thread length	Hole diameter
			d	L	l_s	d_f
			[mm]	[mm]	[mm]	[mm]
M6	R-ITS-Z-06075	R-ITS-A4-06075	10	75	24	7
M8	R-ITS-Z-08075	R-ITS-A4-08075	12	75	25	9
	R-ITS-Z-08090	R-ITS-A4-08090	12	90	25	9
M10	R-ITS-Z-10075	R-ITS-A4-10075	16	75	30	12
	R-ITS-Z-10100	R-ITS-A4-10100	16	100	30	12
M12	R-ITS-Z-12100	R-ITS-A4-12100	16	100	35	14
M16	R-ITS-Z-16125	R-ITS-A4-16125	24	125	50	18

Installation data

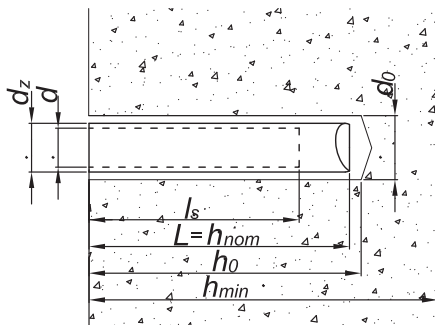

SOCKETS

Size			M6	M8	M10	M12	M16		
Installation depth	h_{nom}	[mm]	75	75	90	75	100	100	125
Thread diameter	d	[mm]	6	8	8	10	10	12	16
Hole diameter in substrate	d_0	[mm]	12	14	14	20	20	20	28
Hole diameter in fixture	d_f	[mm]	7	9	9	12	12	14	18
Thread engagement length	h_s	[mm]	6-24	8-25	8-25	10-30	10-30	12-35	16-50
Min. hole depth in substrate	h_0	[mm]	$h_{nom} + 5$	$h_{nom} + 5$	$h_{nom} + 5$	$h_{nom} + 5$	$h_{nom} + 5$	$h_{nom} + 5$	$h_{nom} + 5$
Min. substrate thickness	h_{min}	[mm]	$h_{nom} + 30$ ≥ 100	$h_{nom} + 30$ ≥ 100	$h_{nom} + 30$ ≥ 100	$h_{nom} + 2d_0$	$h_{nom} + 2d_0$	$h_{nom} + 2d_0$	$h_{nom} + 2d_0$
Installation torque	T_{inst}	[Nm]	3	5	5	10	10	20	40
Min. spacing	s_{min}	[mm]	40	40	50	40	50	50	70
Min. edge distance	c_{min}	[mm]	40	40	50	40	50	50	70

Installation data (cont.)

Minimum working and curing time

Resin temperature	Concrete temperature	Working time	Curing time*
[°C]	[°C]	[min]	[min]
5	5	150	2880
10	10	120	1080
20	20	35	480
25	30	12	300

* For wet concrete the curing time must be doubled

Mechanical properties

SOCKETS

Size			M6	M8	M10	M12	M16
R-ITS-Z INTERNALLY THREADED SOCKETS							
Nominal ultimate tensile strength - tension	f_{uk}	[N/mm ²]	520	500	500	500	500
Nominal yield strength - tension	f_{yk}	[N/mm ²]	420	400	400	400	400
Cross sectional area - tension	A_s	[mm ²]	20.1	36.6	58	84.3	157
Elastic section modulus	W_{el}	[mm ³]	21.2	50.3	98.2	169.7	402.1
R-ITS-A4 INTERNALLY THREADED SOCKETS							
Nominal ultimate tensile strength - tension	f_{uk}	[N/mm ²]	700	700	700	700	700
Nominal yield strength - tension	f_{yk}	[N/mm ²]	350	350	350	350	350
Cross sectional area - tension	A_s	[mm ²]	20.1	36.6	58	84.3	157
Elastic section modulus	W_{el}	[mm ³]	21.2	50.3	98.2	169.7	402.1
R-STUDS METRIC THREADED RODS - steel class 5.8							
Characteristic bending resistance	$M_{Rk,s}^0$	[Nm]	8	19	37	65	166
Design bending resistance	M	[Nm]	6	15	30	52	133
Allowable bending resistance	M_{rec}	[Nm]	5	11	21	37	95
R-STUDS METRIC THREADED RODS - steel class 8.8							
Characteristic bending resistance	$M_{Rk,s}^0$	[Nm]	12	30	60	105	266
Design bending resistance	M	[Nm]	10	24	48	84	213
Allowable bending resistance	M_{rec}	[Nm]	7	17	34	60	152
R-STUDS METRIC THREADED RODS - A4							
Characteristic bending resistance	$M_{Rk,s}^0$	[Nm]	11	26	52	92	233
Design bending resistance	M	[Nm]	7	17	34	59	149
Allowable bending resistance	M_{rec}	[Nm]	5	12	24	42	107

Basic performance data

SOCKETS

Performance data for single anchor without influence of edge distance and spacing

Size		M6	M8	M10	M12	M16
Substrate		Non-cracked concrete				
Embedment depth h_{ef}	[mm]	75	90	75	100	125
CHARACTERISTIC LOAD						
TENSION LOAD N_{Rk}						
R-STUDS METRIC THREADED RODS - STEEL CLASS 5.8	[kN]	10.0	18.0	18.0	29.0	42.0
R-STUDS METRIC THREADED RODS - STEEL CLASS 8.8	[kN]	16.0	29.0	29.0	32.8	46.0
R-STUDS METRIC THREADED RODS - A4	[kN]	14.0	26.0	26.0	32.8	41.0
SHEAR LOAD V_{Rk}						
R-STUDS METRIC THREADED RODS - STEEL CLASS 5.8	[kN]	5.0	9.0	9.0	14.0	21.0
R-STUDS METRIC THREADED RODS - STEEL CLASS 8.8	[kN]	8.0	15.0	15.0	23.0	34.0
R-STUDS METRIC THREADED RODS - A4	[kN]	7.0	13.0	13.0	20.0	29.0

Basic performance data (cont.)

SOCKETS

Performance data for single anchor without influence of edge distance and spacing

Size		M6	M8	M10	M12	M16		
DESIGN LOAD								
TENSION LOAD N_{Rd}								
R-STUDS METRIC THREADED RODS - STEEL CLASS 5.8	[kN]	6.67	12.0	12.0	18.2	19.3	28.0	39.2
R-STUDS METRIC THREADED RODS - STEEL CLASS 8.8	[kN]	10.5	18.2	19.3	18.2	28.1	28.1	39.2
R-STUDS METRIC THREADED RODS - A4	[kN]	7.49	13.9	13.9	18.2	21.9	28.1	39.2
SHEAR LOAD V_{Rd}								
R-STUDS METRIC THREADED RODS - STEEL CLASS 5.8	[kN]	4.0	7.2	7.2	11.2	11.2	16.8	31.2
R-STUDS METRIC THREADED RODS - STEEL CLASS 8.8	[kN]	6.4	12.0	12.0	18.4	18.4	27.2	50.4
R-STUDS METRIC THREADED RODS - A4	[kN]	4.49	8.33	8.33	12.8	12.8	18.6	35.3
RECOMMENDED LOAD								
TENSION LOAD N_{rec}								
R-STUDS METRIC THREADED RODS - STEEL CLASS 5.8	[kN]	4.76	8.57	8.57	13.0	13.8	20.0	28.0
R-STUDS METRIC THREADED RODS - STEEL CLASS 8.8	[kN]	7.50	13.0	13.8	13.0	20.1	20.0	28.0
R-STUDS METRIC THREADED RODS - A4	[kN]	5.35	9.93	9.93	13.0	15.6	20.0	28.0
SHEAR LOAD V_{rec}								
R-STUDS METRIC THREADED RODS - STEEL CLASS 5.8	[kN]	2.86	5.14	5.14	8.0	8.0	12.0	22.3
R-STUDS METRIC THREADED RODS - STEEL CLASS 8.8	[kN]	4.57	8.57	8.57	13.1	13.1	19.4	36.0
R-STUDS METRIC THREADED RODS - A4	[kN]	3.21	5.95	5.95	9.16	9.16	13.3	25.2

Product commercial data

Product Code	Volume [ml]	Quantity [pcs]			Weight [kg]			Bar Code	Shelf Life [month]
		Box	Outer	Pallet	Box	Outer	Pallet		
R-KEX-II-385	385	10	10	380	6.7	6.7	285.0	5906675028538	20
R-KEX-II-600	600	7	7	441	7.0	7.0	472.7	5906675293721	20

R-KEX II with Rebar as an Anchor

Premium pure epoxy resin approved for use with reinforcement bars



Installation movie



Approvals and Reports

• ETA-13/0455



Product overview

Features and benefits

- Approved for use with rebar as an anchor in cracked and non-cracked concrete (EAD 330499-00-0601)
- Suitable for use in dry and wet substrates including under water
- Very high chemical resistance – suitable for applications exposed to influence of various agents (industrial or marine environment)
- Minimal shrinkage provides the option to use in diamond drilled holes and over-sized holes
- Extended bonding time ensures easy installation of metal components (up to 35 min in 20°C)
- For use above 0° C
- Seismic category C1
- Diamond and hammer drilling
- Special mixer nozzle - allows for precise mixing of the product

Applications

- Safety barriers
- Temporary works/formworks support systems
- Curtain walling
- Formwork supports
- Masonry support
- Platforms
- Steelwork
- Rebar dowelling
- Starter bars
- Rebar missed-outs

Base materials

Approved for use in:

- Non-cracked concrete C20/25-C50/60
- Cracked concrete C20/25-C50/60

Installation guide

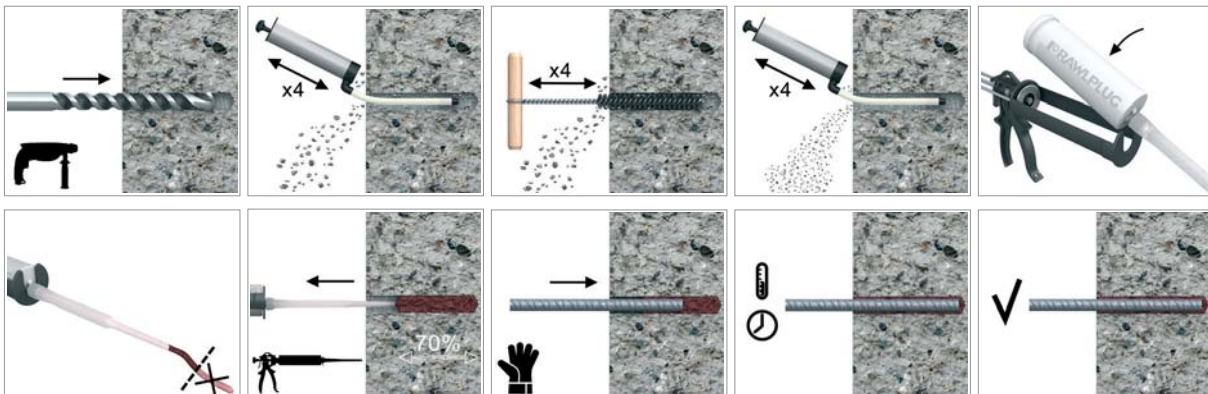

Installation guide (cont.)

1. Drill hole to the required diameter and depth for rebar size being used.
2. Clean the drill hole thoroughly with brush and hand pump at least four times before installation.
3. Attach nozzle and insert cartridge into gun.
4. Dispense to waste until even colour is obtained.
5. Insert the mixer nozzle to the bottom of the drill hole and inject resin, slowly withdrawing the nozzle as the hole is filled to 70% of its depth.
6. Immediately insert the rebar, slowly and with slight twisting motion. Remove any excess resin around the hole before it sets and leave it undisturbed until the curing time elapses.

Product information

Product Code	Resin	Description / Resin Type	Volume
			[m ^l]
R-KEX-II-385	R-KEX II	Epoxy Resin	385
R-KEX-II-600	R-KEX II	Epoxy Resin	600

Installation data

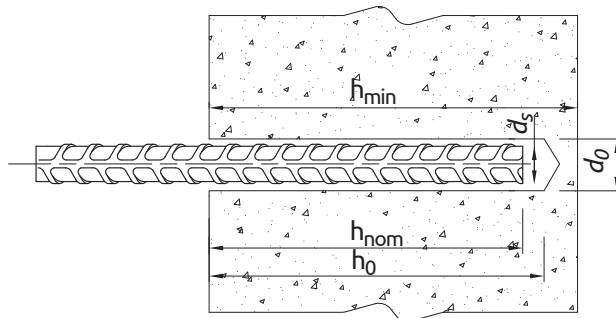

REBARS AS ANCHORS

Size			Ø8	Ø10	Ø12	Ø14	Ø16	Ø20	Ø25	Ø32
Rebar diameter	d_s	[mm]	8	10	12	14	16	20	25	32
Hole diameter in substrate	d_0	[mm]	12	14	18	18	22	26	32	40
Min. hole depth in substrate	h_0	[mm]	$h_{nom} + 5$	$h_{nom} + 5$	$h_{nom} + 5$	$h_{nom} + 5$	$h_{nom} + 5$	$h_{nom} + 5$	$h_{nom} + 5$	$h_{nom} + 5$
Min. substrate thickness	h_{min}	[mm]	$\frac{h_{nom} + 30}{\geq 100}$	$\frac{h_{nom} + 30}{\geq 100}$	$\frac{h_{nom} + 30}{\geq 100}$	$\frac{h_{nom} + 30}{\geq 100}$	$\frac{h_{nom} + 2d_0}{\geq 100}$	$\frac{h_{nom} + 2d_0}{\geq 100}$	$\frac{h_{nom} + 2d_0}{\geq 100}$	$\frac{h_{nom} + 2d_0}{\geq 100}$
Min. spacing	s_{min}	[mm]	40	40	40	40	50	60	70	85
Min. edge distance	c_{min}	[mm]	40	40	40	40	50	60	70	85
MINIMUM EMBEDMENT DEPTH										
Installation depth	$h_{nom, min}$	[mm]	60	70	80	80	100	120	140	165
MAXIMUM EMBEDMENT DEPTH										
Installation depth	$h_{nom, max}$	[mm]	160	200	240	280	320	400	500	640

Minimum working and curing time

Resin temperature	Concrete temperature	Working time	Curing time*
[°C]	[°C]	[min]	[min]
5	5	150	2880
10	10	120	1080
20	20	35	480
25	30	12	300

*For wet concrete the curing time must be doubled

Mechanical properties

REBARS AS ANCHORS

Size			Ø8	Ø10	Ø12	Ø14	Ø16	Ø20	Ø25	Ø32
f_{uk} = 540 (e.g. 500 B acc. to BS 4449; B 500 B acc. to SS 560)										
Nominal ultimate tensile strength - tension	f _{uk}	[N/mm ²]	540	540	540	540	540	540	540	540
Nominal yield strength - tension	f _{yk}	[N/mm ²]	500	500	500	500	500	500	500	500
Cross sectional area - tension	A _s	[mm ²]	50.3	78.5	113.1	153.9	201.1	314.2	490.9	804.2
Elastic section modulus	W _{el}	[mm ³]	50.3	98.2	169.6	269.4	402.1	785.4	1534	3217
f_{uk} = 575 (e.g. B 500 SP acc. to EC2)										
Nominal ultimate tensile strength - tension	f _{uk}	[N/mm ²]	575	575	575	575	575	575	575	575
Nominal yield strength - tension	f _{yk}	[N/mm ²]	500	500	500	500	500	500	500	500
Cross sectional area - tension	A _s	[mm ²]	50.3	78.5	113.1	153.9	201.1	314.2	490.9	804.2
Elastic section modulus	W _{el}	[mm ³]	50.3	98.2	169.6	269.4	402.1	785.4	1534	3217
f_{uk} = 620 (e.g. G-60 acc. to ASTM 615)										
Nominal ultimate tensile strength - tension	f _{uk}	[N/mm ²]	620	620	620	620	620	620	620	620
Nominal yield strength - tension	f _{yk}	[N/mm ²]	420	420	420	420	420	420	420	420
Cross sectional area - tension	A _s	[mm ²]	50.3	78.5	113.1	153.9	201.1	314.2	490.9	804.2
Elastic section modulus	W _{el}	[mm ³]	50.3	98.2	169.6	269.4	402.1	785.4	1534	3217

Basic performance data

REBARS AS ANCHORS

Size		Ø8	Ø10	Ø12	Ø14	Ø16	Ø20	Ø25	Ø32	Ø8	Ø10	Ø12	Ø14	Ø16	Ø20	Ø25	Ø32
Substrate		Non-cracked concrete									Cracked concrete						
CHARACTERISTIC LOAD																	
TENSION LOAD N _{Rd}																	
f _{uk} = 540 (e.g. 500 B acc. to BS 4449; B 500 B acc. to SS 560)																	
Minimum embedment depth	[kN]	16.6	26.4	36.1	35.2	50.5	66.4	83.7	107.0	8.29	11.0	16.6	19.4	25.1	37.7	59.6	66.4
Maximum embedment depth	[kN]	27.1	42.4	61.1	83.1	108.6	169.7	265.1	434.3	22.1	31.4	49.8	58.1	80.4	125.7	216.0	257.4
f _{uk} = 575 (e.g. B 500 SP acc. to EC2)																	
Minimum embedment depth	[kN]	16.6	26.4	36.1	35.2	50.5	66.4	83.7	107.0	8.29	11.0	16.6	19.4	25.1	37.7	59.6	66.4
Maximum embedment depth	[kN]	28.9	45.2	65.0	88.5	115.6	180.6	282.3	462.4	22.1	31.4	49.8	58.1	80.4	125.7	216.0	257.4
f _{uk} = 620 (e.g. G-60 acc. to ASTM 615)																	
Minimum embedment depth	[kN]	16.6	26.4	36.1	35.2	50.5	66.4	83.7	107.0	8.29	11.0	16.6	19.4	25.1	37.7	59.6	66.4
Maximum embedment depth	[kN]	31.2	48.7	70.1	95.4	124.7	194.8	304.3	482.6	22.1	31.4	49.8	58.1	80.4	125.7	216.0	257.4
SHEAR LOAD V _{Rd}																	
f _{uk} = 540 (e.g. 500 B acc. to BS 4449; B 500 B acc. to SS 560)																	
Minimum embedment depth	[kN]	13.6	21.2	30.5	41.6	54.3	84.8	132.5	214.1	13.6	21.2	30.5	33.5	50.3	75.4	119.3	90.1
Maximum embedment depth	[kN]	13.6	21.2	30.5	41.6	54.3	84.8	132.5	217.2	13.6	21.2	30.5	41.6	54.3	84.8	132.5	217.2
f _{uk} = 575 (e.g. B 500 SP acc. to EC2)																	
Minimum embedment depth	[kN]	14.5	22.6	32.5	44.3	57.8	90.3	141.1	214.1	14.5	22.0	32.5	38.7	50.3	75.4	119.3	132.7
Maximum embedment depth	[kN]	14.5	22.6	32.5	44.3	57.8	90.3	141.1	231.2	14.5	22.6	32.5	44.3	57.8	90.3	141.1	231.2
f _{uk} = 620 (e.g. G-60 acc. to ASTM 615)																	
Minimum embedment depth	[kN]	15.6	24.4	35.1	46.9	62.3	97.4	152.2	214.1	15.6	22.0	33.2	38.7	50.3	75.4	119.3	132.7
Maximum embedment depth	[kN]	15.6	24.4	35.1	46.9	62.3	97.4	152.2	249.3	15.6	24.4	35.1	47.7	62.3	97.4	152.2	249.3

Basic performance data

REBARS AS ANCHORS

Size		Ø8	Ø10	Ø12	Ø14	Ø16	Ø20	Ø25	Ø32	Ø8	Ø10	Ø12	Ø14	Ø16	Ø20	Ø25	Ø32
DESIGN LOAD																	
TENSION LOAD N_{Rd}																	
fuk = 540 (e.g. 500 B acc. to BS 4449; B 500 B acc. to SS 560)																	
Minimum embedment depth	[kN]	9.22	14.7	20.1	19.6	28.1	36.9	46.5	59.5	4.61	4.61	9.22	10.8	14.0	20.9	33.1	36.9
Maximum embedment depth	[kN]	19.4	30.3	43.6	58.6	77.6	121.2	189.3	303.8	12.3	17.5	27.7	32.3	44.7	69.8	120.0	143.0
fuk = 575 (e.g. B 500 SP acc. to EC2)																	
Minimum embedment depth	[kN]	9.22	14.7	20.1	19.6	28.1	36.9	46.5	59.5	4.61	4.61	9.22	10.8	14.0	20.9	33.1	36.9
Maximum embedment depth	[kN]	20.6	32.3	46.5	58.6	82.6	129.0	201.6	303.8	12.3	17.5	27.7	32.3	44.7	69.8	120.0	143.0
fuk = 620 (e.g. G-60 acc. to ASTM 615)																	
Minimum embedment depth	[kN]	9.22	14.7	20.1	19.6	28.1	36.9	46.5	59.5	4.61	4.61	9.22	10.8	14.0	20.9	33.1	36.9
Maximum embedment depth	[kN]	22.3	34.8	50.1	58.6	89.0	139.1	207.3	303.8	12.3	17.5	27.7	32.3	44.7	69.8	120.0	143.0
SHEAR LOAD V_{Rd}																	
fuk = 540 (e.g. 500 B acc. to BS 4449; B 500 B acc. to SS 560)																	
Minimum embedment depth	[kN]	9.05	14.1	20.4	27.7	36.2	56.6	88.4	142.7	9.05	14.1	20.4	22.3	33.5	50.3	79.5	60.1
Maximum embedment depth	[kN]	9.05	14.1	20.4	27.7	36.2	56.6	88.4	144.8	9.05	14.1	20.4	27.7	36.2	56.6	88.4	144.8
fuk = 575 (e.g. B 500 SP acc. to EC2)																	
Minimum embedment depth	[kN]	9.63	15.1	21.7	29.5	38.5	60.2	94.1	142.7	9.63	14.7	21.7	25.8	33.5	50.3	79.5	88.5
Maximum embedment depth	[kN]	9.63	15.1	21.7	29.5	38.5	60.2	94.1	154.2	9.63	15.1	21.7	29.5	38.5	60.2	94.1	154.2
fuk = 620 (e.g. G-60 acc. to ASTM 615)																	
Minimum embedment depth	[kN]	10.4	16.2	23.4	31.3	41.6	64.9	101.5	142.7	10.4	14.7	22.1	25.8	33.5	50.3	79.5	88.5
Maximum embedment depth	[kN]	10.4	16.2	23.4	31.3	41.6	64.9	101.5	166.2	10.4	16.2	23.4	31.3	41.6	64.9	101.5	166.2
RECOMMENDED LOAD																	
TENSION LOAD N_{rec}																	
fuk = 540 (e.g. 500 B acc. to BS 4449; B 500 B acc. to SS 560)																	
Minimum embedment depth	[kN]	6.58	10.5	14.3	14.0	20.0	26.3	33.2	42.5	3.29	4.36	6.58	7.68	9.97	15.0	23.7	26.3
Maximum embedment depth	[kN]	13.9	21.6	31.2	41.9	55.4	86.6	135.2	217.0	8.78	12.5	19.8	23.0	31.9	49.9	85.7	102.0
fuk = 575 (e.g. B 500 SP acc. to EC2)																	
Minimum embedment depth	[kN]	6.58	10.5	14.3	14.0	20.0	26.3	33.2	42.5	3.29	4.36	6.58	7.68	9.97	15.0	23.7	26.3
Maximum embedment depth	[kN]	14.8	23.0	33.2	41.9	59.0	92.2	144.0	217.0	8.78	12.5	19.8	23.0	31.9	49.9	85.7	102.0
fuk = 620 (e.g. G-60 acc. to ASTM 615)																	
Minimum embedment depth	[kN]	6.58	10.5	14.3	14.0	20.0	26.3	33.2	42.5	3.29	4.36	6.58	7.68	9.97	15.0	23.7	26.3
Maximum embedment depth	[kN]	15.9	24.8	35.8	41.9	63.6	99.4	148.0	217.0	8.78	12.5	19.8	23.0	31.9	49.9	85.7	102.0
SHEAR LOAD V_{rec}																	
fuk = 540 (e.g. 500 B acc. to BS 4449; B 500 B acc. to SS 560)																	
Minimum embedment depth	[kN]	6.46	10.1	14.5	19.8	25.9	40.4	63.1	101.9	6.46	10.1	14.5	15.9	23.9	35.9	56.8	42.9
Maximum embedment depth	[kN]	6.46	10.1	14.5	19.8	25.9	40.4	63.1	103.4	6.46	10.1	14.5	19.8	25.9	40.4	63.1	103.4
fuk = 575 (e.g. B 500 SP acc. to EC2)																	
Minimum embedment depth	[kN]	6.88	10.8	15.5	21.1	27.5	43.0	67.2	101.9	6.88	10.5	15.5	18.4	23.9	35.9	56.8	63.2
Maximum embedment depth	[kN]	6.88	10.8	15.5	21.1	27.5	43.0	67.2	101.1	6.88	10.8	15.5	21.1	27.5	43.0	67.2	110.1
fuk = 620 (e.g. G-60 acc. to ASTM 615)																	
Minimum embedment depth	[kN]	7.42	11.6	16.7	22.4	29.7	46.4	72.5	101.9	7.42	10.5	15.8	18.4	23.9	35.9	56.8	63.2
Maximum embedment depth	[kN]	7.42	11.6	16.7	22.7	29.7	46.4	72.5	118.7	7.42	11.6	16.7	22.7	29.7	46.4	72.5	118.7

Product commercial data

Product Code	Volume [ml]	Quantity [pcs]			Weight [kg]			Bar Code	Shelf Life [month]
		Box	Outer	Pallet	Box	Outer	Pallet		
R-KEX-II-385	385	10	10	380	6.7	6.7	285.0	5906675028538	20
R-KEX-II-600	600	7	7	441	7.0	7.0	472.7	5906675293721	20

R-KEX II with Post-Installed Rebar

Premium pure epoxy resin approved for use with post-installed rebar connections



Installation movie



Approvals and Reports

- ETA-13/0585



Product overview

Features and benefits

- Approved for use with post-installed rebars in concrete (EAD 330087-00-0601)
- Suitable for use in dry and wet substrates including under water
- High depth of anchoring – 2,5 m for rebar applications
- Very high chemical resistance – suitable for applications exposed to influence of various agents (industrial or marine environment)
- Minimal shrinkage provides the option to use in diamond drilled holes
- Extended bonding time ensures easy installation of metal components (up to 30 min in +20°C)
- For use in positive temperatures
- Diamond and hammer drilling
- Special mixer nozzle - allows for precise mixing of the product

Applications

- Post-installed rebar connections
- Rebar
- Rebar dowelling
- Rebar missed-outs
- Strengthening reinforced concrete structures
- Starter bars
- Expansion of the stairs
- Renovation and modernization of bridges
- Installation of pavement cover

Base materials

Approved for use in:

- Concrete C12/15-C50/60

Installation guide

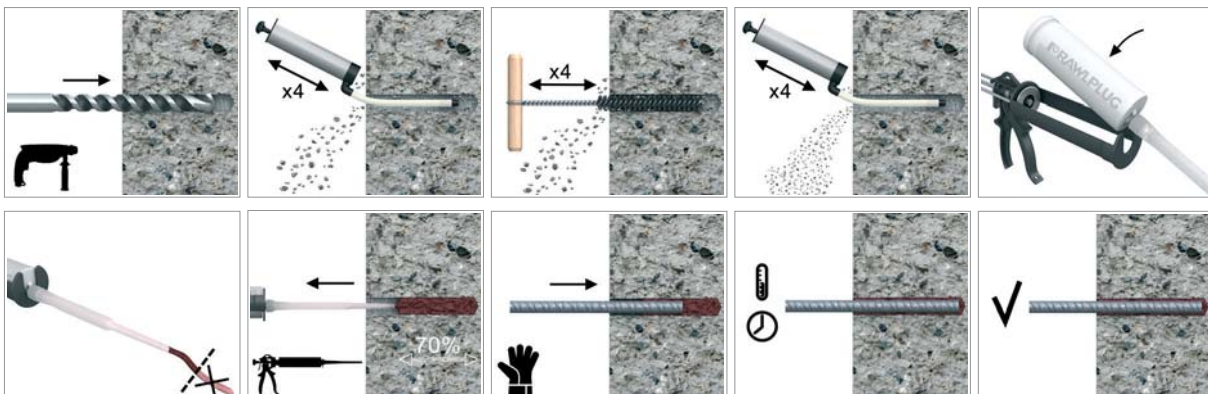

Installation guide (cont.)

1. Drill hole to the required diameter and depth for rebar size being used.
2. Clean the drill hole thoroughly with brush and hand pump at least four times before installation.
3. Attach nozzle and insert cartridge into gun.
4. Dispense to waste until even colour is obtained.
5. Insert the mixer nozzle to the bottom of the drill hole and inject resin, slowly withdrawing the nozzle as the hole is filled to 70% of its depth.
6. Immediately insert the rebar, slowly and with slight twisting motion. Remove any excess resin around the hole before it sets and leave it undisturbed until the curing time elapses.

Product information

Product Code	Resin	Description / Resin Type	Volume
			[m]
R-KEX-II-385	R-KEX II	Epoxy Resin	385
R-KEX-II-600	R-KEX II	Epoxy Resin	600

Installation data

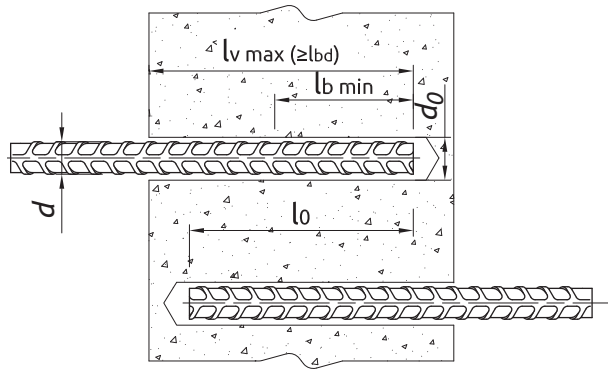

POST INSTALLED REBARS

Size		Ø8	Ø10	Ø12	Ø13	Ø14	Ø16	Ø18	Ø20	Ø22	Ø25	Ø28	Ø30	Ø32	Ø34	Ø36	Ø40
Rebar diameter	d_s [mm]	8	10	12	13	14	16	18	20	22	25	28	30	32	34	36	40
Hole diameter in substrate	d_0 [mm]	12	14	16	16	18	20	22	25	26	30	35	35	40	45	45	50
Brush diameter	- [mm]	14	16	18	18	20	22	24	27	27	32	37	37	42	47	47	52
Min. anchorage length	$l_{v, min.}$ [mm]	115	145	170	185	200	230	260	285	315	355	400	420	455	485	510	570
Min. lap length (overlap splice)	$l_{b, min.}$ [mm]	200	215	260	270	300	345	430	430	470	535	600	640	690	725	770	855
Max. anchorage length	$l_{v, max.}$ [mm]	400	500	600	700	700	800	900	1000	1100	1200	1400	1500	2500	2000	2000	2000

Minimum working and curing time

Resin temperature	Concrete temperature	Working time	Curing time*
[°C]	[°C]	[min]	[min]
5	5	150	2880
10	10	120	1080
20	20	35	480
25	30	12	300

*For wet concrete the curing time must be doubled

Mechanical properties

POST INSTALLED REBARS

Size	Ø8	Ø10	Ø12	Ø13	Ø14	Ø16	Ø18	Ø20	Ø22	Ø25	Ø28	Ø30	Ø32	Ø34	Ø36	Ø40	
fyk = 410 (e.g. 34GS acc. to EC2)																	
Nominal yield strength - tension	f_{yk} [N/mm ²]	41	41	41	41	41	41	41	41	41	41	41	41	41	41	41	
Cross sectional area - tension	A_s [mm ²]	50	78	113	132	153	201	254	314	380	490	615	706	804	907	1018	1257
fyk = 420 (e.g. G-60 acc. to ASTM 615)																	
Nominal yield strength - tension	f_{yk} [N/mm ²]	42	42	42	42	42	42	42	42	42	42	42	42	42	42	42	
Cross sectional area - tension	A_s [mm ²]	50	78	113	132	153	201	254	314	380	490	615	706	804	907	1018	1257
fyk = 460 (e.g. 460 B acc. to BS 4449)																	
Nominal yield strength - tension	f_{yk} [N/mm ²]	46	46	46	46	46	46	46	46	46	46	46	46	46	46	46	
Cross sectional area - tension	A_s [mm ²]	50	78	113	132	153	201	254	314	380	490	615	706	804	907	1018	1257
fyk = 500 (e.g. B 500 SP acc. to EC2; 500 B acc. to BS 4449; B 500 B acc. to SS 560)																	
Nominal yield strength - tension	f_{yk} [N/mm ²]	50	50	50	50	50	50	50	50	50	50	50	50	50	50	50	
Cross sectional area - tension	A_s [mm ²]	50	78	113	132	153	201	254	314	380	490	615	706	804	907	1018	1257
fyk = 600 (e.g. B 600 B acc. to SS 560)																	
Nominal yield strength - tension	f_{yk} [N/mm ²]	60	60	60	60	60	60	60	60	60	60	60	60	60	60	60	
Cross sectional area - tension	A_s [mm ²]	50	78	113	132	153	201	254	314	380	490	615	706	804	907	1018	1257

Basic performance data

ANCHORAGES – DESIGN RESISTANCE – CONCRETE C20/25, NOMINAL YIELD STRENGTH FOR TENSION - $f_{yk} = 410$ [N/mm ²]																										
d_s [mm]	l_{bd} [mm]	100	120	140	160	180	200	250	300	350	400	450	500	550	600	650	700	750	800	900	1000	1250	1500	2000	2500	Steel failure
		8	5,8	6,9	8,1	9,2	10,4	11,6	14,5	17,3	17,9	17,9	-	-	-	-	-	-	-	-	-	-	-	-	-	-
10	-	8,7	10,1	11,6	13,0	14,5	18,1	21,7	25,3	28,0	28,0	28,0	-	-	-	-	-	-	-	-	-	-	-	-	-	28,0
12	-	-	12,1	13,9	15,6	17,3	21,7	26,0	30,3	34,7	39,0	40,3	40,3	40,3	-	-	-	-	-	-	-	-	-	-	-	40,3
13	-	-	-	15,0	16,9	18,8	23,5	28,2	32,9	37,6	42,3	47,0	47,3	47,3	47,3	47,3	-	-	-	-	-	-	-	-	-	47,3
14	-	-	-	-	18,2	20,2	25,3	30,3	35,4	40,5	45,5	50,6	54,9	54,9	54,9	54,9	-	-	-	-	-	-	-	-	-	54,9
16	-	-	-	-	-	23,1	28,9	34,7	40,5	46,2	52,0	57,8	63,6	69,4	71,7	71,7	71,7	71,7	71,7	-	-	-	-	-	-	71,7
18	-	-	-	-	-	-	32,5	39,0	45,5	52,0	58,5	65,0	71,5	78,0	84,5	90,7	90,7	90,7	90,7	90,7	-	-	-	-	-	90,7
20	-	-	-	-	-	-	36,1	43,4	50,6	57,8	65,0	72,3	79,5	86,7	93,9	101,2	108,4	112,0	112,0	112,0	-	-	-	-	-	112,0
22	-	-	-	-	-	-	-	47,7	55,6	63,6	71,5	79,5	87,4	95,4	103,3	111,3	119,2	127,2	135,5	135,5	-	-	-	-	-	135,5
25	-	-	-	-	-	-	-	54,2	63,2	72,3	81,3	90,3	99,4	108,4	117,4	126,4	135,5	144,5	162,6	175,0	-	-	-	-	-	175,0
28	-	-	-	-	-	-	-	-	70,8	80,9	91,0	101,2	111,3	121,4	131,5	141,6	151,7	161,9	182,1	202,3	219,5	-	-	-	-	219,5
30	-	-	-	-	-	-	-	75,9	86,7	97,5	108,4	119,2	130,1	140,9	151,7	162,6	173,4	185,0	208,1	231,2	252,0	252,0	-	-	-	252,0
32	-	-	-	-	-	-	-	-	92,5	104,0	115,6	127,2	138,7	150,3	161,9	173,4	185,0	208,1	231,2	286,7	286,7	286,7	286,7	-	-	286,7
34	-	-	-	-	-	-	-	-	98,3	110,6	122,8	135,1	147,4	159,7	172,0	184,3	196,5	221,1	245,7	307,1	323,7	323,7	323,7	-	-	323,7
36	-	-	-	-	-	-	-	-	-	117,1	130,1	143,1	156,1	169,1	182,1	195,1	208,1	234,1	260,1	325,2	362,9	362,9	362,9	-	-	362,9
40	-	-	-	-	-	-	-	-	-	113,1	125,7	138,2	150,8	163,4	175,9	188,5	201,1	226,2	251,3	314,2	377,0	448,0	448,0	-	-	448,0

ANCHORAGES – DESIGN RESISTANCE – CONCRETE C50/60, NOMINAL YIELD STRENGTH FOR TENSION - $f_{yk} = 410$ [N/mm ²]																										
d_s [mm]	l_{bd} [mm]	100	120	140	160	180	200	250	300	350	400	450	500	550	600	650	700	750	800	900	1000	1250	1500	2000	2500	Steel failure
		8	10,8	13,0	15,1	17,3	17,9	17,9	17,9	17,9	17,9	-	-	-	-	-	-	-	-	-	-	-	-	-	-	-
10	13,5	16,2	18,9	21,6	24,3	27,0	28,0	28,0	28,0	28,0	28,0	28,0	-	-	-	-	-	-	-	-	-	-	-	-	-	28,0
12	-	19,5	22,7	25,9	29,2	32,4	40,3	40,3	40,3	40,3	40,3	40,3	40,3	-	-	-	-	-	-	-	-	-	-	-	-	40,3
13	-	-	24,6	28,1	31,6	35,1	43,9	47,3	47,3	47,3	47,3	47,3	47,3	47,3	47,3	47,3	47,3	-	-	-	-	-	-	-	-	47,3
14	-	-	26,5	30,3	34,0	37,8	47,3	54,9	54,9	54,9	54,9	54,9	54,9	54,9	54,9	54,9	54,9	-	-	-	-	-	-	-	-	54,9
16	-	-	-	32,2	36,2	40,2	50,3	60,3	70,4	71,7	71,7	71,7	71,7	71,7	71,7	71,7	71,7	71,7	71,7	-	-	-	-	-	-	71,7
18	-	-	-	-	40,7	45,2	56,5	67,9	79,2	90,7	90,7	90,7	90,7	90,7	90,7	90,7	90,7	90,7	90,7	90,7	-	-	-	-	-	90,7
20	-	-	-	-	-	46,5	58,1	69,7	81,4	93,0	104,6	112,0	112,0	112,0	112,0	112,0	112,0	112,0	112,0	112,0	112,0	-	-	-	-	112,0
22	-	-	-	-	-	-	63,9	76,7	89,5	102,3	115,0	127,9	135,5	135,5	135,5	135,5	135,5	135,5	135,5	135,5	135,5	-	-	-	-	135,5
25	-	-	-	-	-	-	66,8	80,1	93,5	106,8	120,2	133,5	146,9	173,6	175,0	175,0	175,0	175,0	175,0	175,0	175,0	-	-	-	-	175,0
28	-	-	-	-	-	-	-	89,7	104,7	119,6	134,6	149,5	164,5	179,4	194,4	209,4	219,5	219,5	219,5	219,5	219,5	219,5	-	-	-	219,5
30	-	-	-	-	-	-	-	84,8	99,0	113,1	127,2	141,4	155,5	169,6	183,8	197,9	212,1	226,2	252,0	252,0	252,0	252,0	-	-	-	252,0
32	-	-	-	-	-	-	-	-	95,0	108,6	122,1	135,7	149,3	162,9	176,4	190,0	203,6	217,1	244,3	271,4	286,7	286,7	286,7	286,7	-	286,7
34	-	-	-	-	-	-	-	-	100,9	115,4	129,8	144,2	158,6	173,0	187,5	201,9	216,3	230,7	259,6	288,4	323,7	323,7	323,7	-	-	323,7
36	-	-	-	-	-	-	-	-	-	-	117,1	130,1	143,1	156,1	169,1	182,1	195,1	208,1	234,1	260,1	352,2	362,9	362,9	-	-	362,9
40	-	-	-	-	-	-	-	-	-	-	-	125,7	138,2	150,8	163,4	175,9	188,5	201,1	226,2	251,3	314,2	377,0	448,0	-	-	448,0

All products listed in this publication are branded and distributed with RAWLPLUG® or RAWL® trademarks.

Basic performance data (cont.)

OVERLAP SPLICE – DESIGN RESISTANCE – CONCRETE C20/25, NOMINAL YIELD STRENGTH FOR TENSION - $f_{yk} = 410$ [N/mm ²]																											
d_s [mm]	l_{bd} [mm]	200	220	240	260	280	300	325	350	375	400	450	500	550	600	650	700	750	800	900	1000	1250	1500	2000	2500	Steel failure	
8		11,6	12,7	13,9	15,0	16,2	17,3	17,9	17,9	17,9	17,9	-	-	-	-	-	-	-	-	-	-	-	-	-	-	17,9	
10		14,5	15,9	17,3	18,8	20,2	21,7	23,5	25,3	27,1	28,0	28,0	28,0	-	-	-	-	-	-	-	-	-	-	-	-	28,0	
12		-	19,1	20,8	22,5	24,3	26,0	28,2	30,3	32,5	34,7	39,0	40,3	40,3	40,3	-	-	-	-	-	-	-	-	-	-	40,3	
13		-	-	22,5	24,4	26,3	28,2	30,5	32,9	35,2	37,6	42,3	47,0	47,3	47,3	47,3	47,3	-	-	-	-	-	-	-	-	47,3	
14		-	-	-	26,3	28,3	30,3	32,9	35,4	37,9	40,5	45,5	50,6	54,9	54,9	54,9	54,9	-	-	-	-	-	-	-	-	54,9	
16		-	-	-	-	32,4	34,7	37,6	40,5	43,4	46,2	52,0	57,8	63,6	69,4	71,7	71,7	71,7	71,7	-	-	-	-	-	-	71,7	
18		-	-	-	-	-	-	42,3	45,5	48,8	52,0	58,5	65,0	71,5	78,0	84,5	90,7	90,7	90,7	90,7	90,7	-	-	-	-	90,7	
20		-	-	-	-	-	-	-	50,6	54,2	57,8	65,0	72,3	79,5	86,7	93,9	101,2	108,4	112,0	112,0	112,0	-	-	-	-	112,0	
22		-	-	-	-	-	-	-	-	-	63,6	71,5	79,5	87,4	95,4	103,3	111,3	119,2	127,2	135,5	135,5	-	-	-	-	135,5	
25		-	-	-	-	-	-	-	-	-	-	81,3	90,3	99,4	108,4	117,4	126,4	135,5	144,5	162,6	175,0	-	-	-	-	175,0	
28		-	-	-	-	-	-	-	-	-	-	-	-	101,2	111,3	121,4	131,5	141,6	151,7	161,9	182,1	202,3	219,5	-	-	219,5	
30		-	-	-	-	-	-	-	-	-	-	-	-	-	119,2	130,1	140,9	151,7	162,6	173,4	195,1	216,8	252,0	252,0	-	252,0	
32		-	-	-	-	-	-	-	-	-	-	-	-	-	-	-	138,7	150,3	161,9	173,4	185,0	208,1	231,2	286,7	286,7	286,7	
34		-	-	-	-	-	-	-	-	-	-	-	-	-	-	147,4	159,7	172,0	184,3	196,5	221,1	245,7	307,1	323,7	323,7	-	323,7
36		-	-	-	-	-	-	-	-	-	-	-	-	-	-	-	169,1	182,1	195,1	208,1	234,1	260,1	325,2	362,9	362,9	-	362,9
40		-	-	-	-	-	-	-	-	-	-	-	-	-	-	-	-	-	188,5	201,1	226,2	251,3	314,2	377,0	448,0	-	448,0

OVERLAP SPLICE – DESIGN RESISTANCE – CONCRETE C50/60, NOMINAL YIELD STRENGTH FOR TENSION - $f_{yk} = 410$ [N/mm ²]																										
d_s [mm]	l_{bd} [mm]	200	220	240	260	280	300	325	350	375	400	450	500	550	600	650	700	750	800	900	1000	1250	1500	2000	2500	Steel failure
8		17,9	17,9	17,9	17,9	17,9	17,9	17,9	17,9	17,9	17,9	-	-	-	-	-	-	-	-	-	-	-	-	-	-	17,9
10		27,0	28,0	28,0	28,0	28,0	28,0	28,0	28,0	28,0	28,0	28,0	28,0	-	-	-	-	-	-	-	-	-	-	-	-	28,0
12		32,4	35,7	38,9	40,3	40,3	40,3	40,3	40,3	40,3	40,3	40,3	40,3	40,3	40,3	-	-	-	-	-	-	-	-	-	-	40,3
13		35,1	38,6	42,1	45,7	47,3	47,3	47,3	47,3	47,3	47,3	47,3	47,3	47,3	47,3	47,3	47,3	-	-	-	-	-	-	-	-	47,3
14		-	41,6	45,4	49,2	53,0	54,9	54,9	54,9	54,9	54,9	54,9	54,9	54,9	54,9	54,9	54,9	-	-	-	-	-	-	-	-	54,9
16		-	-	48,3	52,3	56,3	60,3	65,3	70,4	71,7	71,7	71,7	71,7	71,7	71,7	71,7	71,7	71,7	71,7	-	-	-	-	-	-	71,7
18		-	-	-	-	63,3	67,9	73,5	79,2	84,8	90,5	90,7	90,7	90,7	90,7	90,7	90,7	90,7	90,7	90,7	-	-	-	-	-	90,7
20		-	-	-	-	-	69,7	75,6	81,4	87,2	93,0	104,6	112,0	112,0	112,0	112,0	112,0	112,0	112,0	112,0	112,0	112,0	-	-	-	112,0
22		-	-	-	-	-	-	-	-	89,5	95,9	102,3	115,1	127,9	135,5	135,5	135,5	135,5	135,5	135,5	135,5	135,5	-	-	-	135,5
25		-	-	-	-	-	-	-	-	-	100,1	106,8	120,2	133,5	146,9	160,2	173,6	175,0	175,0	175,0	175,0	175,0	-	-	-	175,0
28		-	-	-	-	-	-	-	-	-	-	134,6	149,5	164,5	179,4	194,4	209,4	219,5	219,5	219,5	219,5	219,5	219,5	-	-	219,5
30		-	-	-	-	-	-	-	-	-	-	127,2	141,4	155,5	169,6	183,8	197,9	212,1	226,2	252,0	252,0	252,0	252,0	-	-	252,0
32		-	-	-	-	-	-	-	-	-	-	-	135,7	149,3	162,9	176,4	190,0	203,6	217,1	244,3	271,4	286,7	286,7	286,7	286,7	286,7
34		-	-	-	-	-	-	-	-	-	-	-	-	158,6	173,0	187,5	201,9	216,3	230,7	259,6	288,4	323,7	323,7	323,7	-	323,7
36		-	-	-	-	-	-	-	-	-	-	-	-	-	-	169,1	182,1	195,1	208,1	234,1	260,1	325,2	362,9	362,9	-	362,9
40		-	-	-	-	-	-	-	-	-	-	-	-	-	-	-	-	188,5	201,1	226,2	251,3	314,2	377,0	448,0	-	448,0

ANCHORAGES – DESIGN RESISTANCE – CONCRETE C20/25, NOMINAL YIELD STRENGTH FOR TENSION - $f_{yk} = 420$ [N/mm ²]																										
d_s [mm]	l_{bd} [mm]	100	120	140	160	180	200	250	300	350	400	450	500	550	600	650	700	750	800	900	1000	1250	1500	2000	2500	Steel failure
8		5,8	6,9	8,1	9,2	10,4	11,6	14,5	17,3	18,4	18,4	-	-	-	-	-	-	-	-	-	-	-	-	-	-	18,4
10		-	8,7	10,1	11,6	13,0	14,5	18,1	21,7	25,3	28,7	28,7	28,7	-	-	-	-	-	-	-	-	-	-	-	-	28,7
12		-	-	-	13,9	15,6	17,3	21,7	26,0	30,3	34,7	39,0	41,3	41,3	41,3	-	-	-	-	-	-	-	-	-	-	41,3
13		-	-	-	15,0	16,9	18,8	23,5	28,2	32,9	37,6	42,3	47,0	48,5	48,5	48,5	48,5	-	-	-	-	-	-	-	-	48,5
14		-	-	-	-	18,2	20,2	25,3	30,3	35,4	40,5	45,5	50,6	55,6	56,2	56,2	56,2	-	-	-	-	-	-	-	-	56,2
16		-	-	-	-	-	23,1	28,9	34,7	40,5	46,2	52,0	57,8	63,6	69,4	73,4	73,4	73,4	73,4	-	-	-	-	-	-	73,4
18		-	-	-	-	-	-	32,5	39,0	45,5	52,0	58,5	65,0	71,5	78,0	84,5	91,0	92,9	92,9	92,9	-	-	-	-	-	92,9
20		-	-	-	-	-	-	36,1	43,4	50,6	57,8	65,0	72,3	79,5	86,7	93,9	101,2	108,4	114,8	114,8	114,8	-	-	-	-	114,8
22		-	-	-	-	-	-	-	47,7	55,6	63,6	71,5	79,5	87,4	95,4	103,3	111,3	119,2	127,2	138,8	138,8	-	-	-	-	138,8
25		-	-	-	-	-	-	-	54,2	63,2	72,3	81,3	90,3	99,4	108,4	117,4	126,4	135,5	144,5	162,6	179,3	-	-	-	-	179,3
28		-	-	-	-	-	-	-	-	70,8	80,9	91,0	101,2	111,3	121,4	131,5	141,6	151,7	161,9	182,1	202,3	224,9	-	-	-	224,9
30		-	-	-	-	-	-	-	75,9	86,7	97,5	108,4	119,2	130,1	140,9	151,7	162,6	173,4	185,0	208,1	231,2	286,7	286,7	-	-	286,7
32		-	-	-	-	-	-	-	-	92,5	104,0	115,6	127,2	138,7	150,3	161,9	173,4	185,0	208,1	231,2	286,7	286,7	286,7	286,7	-	286,7
34		-	-	-	-	-	-	-	-	98,3	110,6	122,8	135,1	147,4	159,7	172,0	184,3	196,5	221,1	245,7	307,1	323,7	323,7	-	-	323,69
36		-	-	-	-	-	-	-	-	-	117,1	130,1	143,1	156,1	169,1	182,1	195,1	208,1	234,1	260,1	325,2	362,9	362,9	-	-	362,89
40		-	-	-	-	-	-	-	-	-	-	125,7	138,2	150,8	163,4	175,9	188,5	201,1	226,2	251,3	314,2	377,0	448,0	-	-	448,01

Basic performance data (cont.)

ANCHORAGES – DESIGN RESISTANCE – CONCRETE C20/25, NOMINAL YIELD STRENGTH FOR TENSION - $f_{yk} = 420$ [N/mm ²]																										
d_s [mm]	l_{bd} [mm]	100	120	140	160	180	200	250	300	350	400	450	500	550	600	650	700	750	800	900	1000	1250	1500	2000	2500	Steel failure
		30	-	-	-	-	-	-	-	-	-	-	86,7	97,5	108,4	119,2	130,1	140,9	151,7	162,6	173,4	195,1	216,8	258,2	258,2	-
32	-	-	-	-	-	-	-	-	-	-	92,5	104,0	115,6	127,2	138,7	150,3	161,9	173,4	185,0	208,1	231,2	289,0	293,7	293,7	293,7	293,7
34	-	-	-	-	-	-	-	-	-	-	-	110,6	122,8	135,1	147,4	159,7	172,0	184,3	196,5	221,1	245,7	307,1	331,6	331,6	-	331,6
36	-	-	-	-	-	-	-	-	-	-	-	117,1	130,1	143,1	156,1	169,1	182,1	195,1	208,1	234,1	260,1	325,2	371,7	371,7	-	371,7
40	-	-	-	-	-	-	-	-	-	-	-	-	-	138,2	150,8	163,4	175,9	188,5	201,1	226,2	251,3	314,2	377,0	458,9	-	458,9

ANCHORAGES – DESIGN RESISTANCE – CONCRETE C50/60, NOMINAL YIELD STRENGTH FOR TENSION - $f_{yk} = 420$ [N/mm ²]																										
d_s [mm]	l_{bd} [mm]	100	120	140	160	180	200	250	300	350	400	450	500	550	600	650	700	750	800	900	1000	1250	1500	2000	2500	Steel failure
		8	10,8	13,0	15,1	17,3	18,4	18,4	18,4	18,4	18,4	18,4	-	-	-	-	-	-	-	-	-	-	-	-	-	-
10	13,5	16,2	18,9	21,6	24,3	27,0	28,7	28,7	28,7	28,7	28,7	28,7	28,7	-	-	-	-	-	-	-	-	-	-	-	-	28,7
12	-	19,5	22,7	25,9	29,2	32,4	40,5	41,3	41,3	41,3	41,3	41,3	41,3	41,3	41,3	-	-	-	-	-	-	-	-	-	-	41,3
13	-	-	24,6	28,1	31,6	35,1	43,9	48,5	48,5	48,5	48,5	48,5	48,5	48,5	48,5	48,5	-	-	-	-	-	-	-	-	-	48,5
14	-	-	26,5	30,3	34,0	37,8	47,3	56,2	56,2	56,2	56,2	56,2	56,2	56,2	56,2	56,2	56,2	-	-	-	-	-	-	-	-	56,2
16	-	-	-	32,2	36,2	40,2	50,3	60,3	70,4	73,4	73,4	73,4	73,4	73,4	73,4	73,4	73,4	73,4	73,4	-	-	-	-	-	-	73,4
18	-	-	-	-	40,7	45,2	56,5	67,9	79,2	90,5	92,9	92,9	92,9	92,9	92,9	92,9	92,9	92,9	92,9	92,9	92,9	-	-	-	-	92,9
20	-	-	-	-	-	46,5	58,1	69,7	81,4	93,0	104,6	114,8	114,8	114,8	114,8	114,8	114,8	114,8	114,8	114,8	114,8	114,8	-	-	-	114,8
22	-	-	-	-	-	-	63,9	76,7	89,5	102,3	115,1	127,9	138,8	138,8	138,8	138,8	138,8	138,8	138,8	138,8	138,8	138,8	-	-	-	138,8
25	-	-	-	-	-	-	66,8	80,1	93,5	106,8	120,2	133,5	146,9	160,2	173,6	179,3	179,3	179,3	179,3	179,3	179,3	179,3	-	-	-	179,3
28	-	-	-	-	-	-	-	89,7	104,7	119,6	134,6	149,5	164,5	179,4	194,4	209,4	224,3	224,9	224,9	224,9	224,9	224,9	-	-	-	224,9
30	-	-	-	-	-	-	-	-	84,8	99,0	113,1	127,2	141,4	155,5	169,6	183,8	197,9	212,1	226,2	254,5	258,2	258,2	258,2	-	-	258,2
32	-	-	-	-	-	-	-	-	-	95,0	108,6	122,1	135,7	149,3	162,9	176,4	190,0	203,6	217,1	244,3	271,4	293,7	293,7	293,7	293,7	293,7
34	-	-	-	-	-	-	-	-	-	100,9	115,4	129,8	144,2	158,6	173,0	187,5	201,9	216,3	230,7	259,6	288,4	331,6	331,6	331,6	-	331,6
36	-	-	-	-	-	-	-	-	-	-	-	117,1	130,1	143,1	156,1	169,1	182,1	195,1	208,1	234,1	260,1	325,2	371,7	371,7	-	371,7
40	-	-	-	-	-	-	-	-	-	-	-	-	-	138,2	150,8	163,4	175,9	188,5	201,1	226,2	251,3	314,2	377,0	458,9	-	458,9

OVERLAP SPLICE – DESIGN RESISTANCE – CONCRETE C20/25, NOMINAL YIELD STRENGTH FOR TENSION - $f_{yk} = 420$ [N/mm ²]																											
d_s [mm]	l_{bd} [mm]	200	220	240	260	280	300	325	350	375	400	450	500	550	600	650	700	750	800	900	1000	1250	1500	2000	2500	Steel failure	
		8	11,6	12,7	13,9	15,0	16,2	17,3	18,4	18,4	18,4	18,4	-	-	-	-	-	-	-	-	-	-	-	-	-	-	-
10	14,5	15,9	17,3	18,8	20,2	21,7	23,5	25,3	27,1	28,7	28,7	28,7	28,7	-	-	-	-	-	-	-	-	-	-	-	-	28,7	
12	-	19,1	20,8	22,5	24,3	26,0	28,2	30,3	32,5	34,7	39,0	41,3	41,3	41,3	41,3	-	-	-	-	-	-	-	-	-	-	41,3	
13	-	-	22,5	24,4	26,3	28,2	30,5	32,9	35,2	37,6	42,3	47,0	48,5	48,5	48,5	48,5	-	-	-	-	-	-	-	-	-	48,5	
14	-	-	-	26,3	28,3	30,3	32,9	35,4	37,9	40,5	45,5	50,6	55,6	56,2	56,2	56,2	56,2	-	-	-	-	-	-	-	-	56,2	
16	-	-	-	-	-	34,7	37,6	40,5	43,4	46,2	52,0	57,8	63,6	69,4	73,4	73,4	73,4	73,4	73,4	-	-	-	-	-	-	73,4	
18	-	-	-	-	-	-	42,3	45,5	48,8	52,0	58,5	65,0	71,5	78,0	84,5	91,0	92,9	92,9	92,9	92,9	-	-	-	-	-	92,9	
20	-	-	-	-	-	-	-	-	-	54,2	57,8	65,0	72,3	79,5	86,7	93,9	101,2	108,4	114,8	114,8	114,8	114,8	-	-	-	114,8	
22	-	-	-	-	-	-	-	-	-	-	63,6	71,5	79,5	87,4	95,4	103,3	111,3	119,2	127,2	138,8	138,8	-	-	-	-	138,8	
25	-	-	-	-	-	-	-	-	-	-	-	81,3	90,3	99,4	108,4	117,4	126,4	135,5	144,5	162,6	179,3	-	-	-	-	179,3	
28	-	-	-	-	-	-	-	-	-	-	-	-	-	111,3	121,4	131,5	141,6	151,7	161,9	182,1	202,3	224,9	-	-	-	224,9	
30	-	-	-	-	-	-	-	-	-	-	-	-	-	-	119,2	130,1	140,9	151,7	162,6	173,4	195,1	216,8	258,2	258,2	-	258,2	
32	-	-	-	-	-	-	-	-	-	-	-	-	-	-	-	138,7	150,3	161,9	173,4	185,0	208,1	231,2	289,0	293,7	293,7	293,7	
34	-	-	-	-	-	-	-	-	-	-	-	-	-	-	-	-	159,7	172,0	184,3	196,5	221,1	245,7	307,1	331,6	331,6	331,6	
36	-	-	-	-	-	-	-	-	-	-	-	-	-	-	-	-	-	169,1	182,1	195,1	208,1	234,1	260,1	325,2	371,7	371,7	
40	-	-	-	-	-	-	-	-	-	-	-	-	-	-	-	-	-	-	-	201,1	226,2	251,3	314,2	377,0	458,9	-	458,9

Basic performance data (cont.)

OVERLAP SPLICE – DESIGN RESISTANCE – CONCRETE C50/60, NOMINAL YIELD STRENGTH FOR TENSION - $f_{yk} = 420$ [N/mm ²]																										
d_s [mm]	l_{bd} [mm]	100	120	140	160	180	200	250	300	350	400	450	500	550	600	650	700	750	800	900	1000	1250	1500	2000	2500	Steel failure
8		18,4	18,4	18,4	18,4	18,4	18,4	18,4	18,4	18,4	-	-	-	-	-	-	-	-	-	-	-	-	-	-	-	18,4
10		27,0	28,7	28,7	28,7	28,7	28,7	28,7	28,7	28,7	28,7	28,7	28,7	-	-	-	-	-	-	-	-	-	-	-	-	28,7
12		32,4	35,7	38,9	41,3	41,3	41,3	41,3	41,3	41,3	41,3	41,3	41,3	41,3	-	-	-	-	-	-	-	-	-	-	-	41,3
13		35,1	38,6	42,1	45,7	48,5	48,5	48,5	48,5	48,5	48,5	48,5	48,5	48,5	48,5	48,5	48,5	-	-	-	-	-	-	-	-	48,5
14		-	41,6	45,4	49,2	53,0	56,2	56,2	56,2	56,2	56,2	56,2	56,2	56,2	56,2	56,2	56,2	-	-	-	-	-	-	-	-	56,2
16		-	-	48,3	52,3	56,3	60,3	65,3	70,4	73,4	73,4	73,4	73,4	73,4	73,4	73,4	73,4	73,4	73,4	-	-	-	-	-	-	73,4
18		-	-	-	63,3	67,9	73,5	79,2	84,8	90,5	92,9	92,9	92,9	92,9	92,9	92,9	92,9	92,9	92,9	92,9	92,9	-	-	-	-	92,9
20		-	-	-	-	69,7	75,6	81,4	87,2	93,0	104,6	114,8	114,8	114,8	114,8	114,8	114,8	114,8	114,8	114,8	114,8	114,8	-	-	-	114,8
22		-	-	-	-	-	-	-	89,5	95,9	102,3	115,1	127,9	138,8	138,8	138,8	138,8	138,8	138,8	138,8	138,8	138,8	-	-	-	138,8
25		-	-	-	-	-	-	-	-	100,1	106,8	120,2	133,5	146,9	160,2	173,6	179,3	179,3	179,3	179,3	179,3	179,3	-	-	-	179,3
28		-	-	-	-	-	-	-	-	-	-	134,6	149,5	164,5	179,4	194,4	209,4	224,3	224,9	224,9	224,9	224,9	224,9	-	-	224,9
30		-	-	-	-	-	-	-	-	-	-	127,2	141,4	155,5	169,6	183,8	197,9	212,1	226,2	254,5	258,2	258,2	258,2	-	-	258,2
32		-	-	-	-	-	-	-	-	-	-	-	135,7	149,3	162,9	176,4	190,0	203,6	217,1	244,3	271,4	293,7	293,7	293,7	-	293,7
34		-	-	-	-	-	-	-	-	-	-	-	-	158,6	173,0	187,5	201,9	216,3	230,7	259,6	288,4	331,6	331,6	331,6	-	331,6
36		-	-	-	-	-	-	-	-	-	-	-	-	-	169,1	182,1	195,1	208,1	234,1	260,1	325,2	371,7	371,7	-	-	371,7
40		-	-	-	-	-	-	-	-	-	-	-	-	-	-	-	-	-	201,1	226,2	251,3	314,2	377,0	458,9	-	458,9

ANCHORAGES – DESIGN RESISTANCE – CONCRETE C20/25, NOMINAL YIELD STRENGTH FOR TENSION - $f_{yk} = 460$ [N/mm ²]																										
d_s [mm]	l_{bd} [mm]	100	120	140	160	180	200	250	300	350	400	450	500	550	600	650	700	750	800	900	1000	1250	1500	2000	2500	Steel failure
8		-	6,9	8,1	9,2	10,4	11,6	14,5	17,3	20,1	20,1	-	-	-	-	-	-	-	-	-	-	-	-	-	-	20,1
10		-	-	10,1	11,6	13,0	14,5	18,1	21,7	25,3	28,9	31,4	31,4	-	-	-	-	-	-	-	-	-	-	-	-	31,4
12		-	-	-	13,9	15,6	17,3	21,7	26,0	30,3	34,7	39,0	43,4	45,2	45,2	-	-	-	-	-	-	-	-	-	-	45,2
13		-	-	-	-	16,9	18,8	23,5	28,2	32,9	37,6	42,3	47,0	51,7	53,1	53,1	53,1	-	-	-	-	-	-	-	-	53,1
14		-	-	-	-	-	20,2	25,3	30,3	35,4	40,5	45,5	50,6	55,6	60,7	61,6	61,6	-	-	-	-	-	-	-	-	61,6
16		-	-	-	-	-	28,9	34,7	40,5	46,2	52,0	57,8	63,6	69,4	75,1	80,4	80,4	80,4	80,4	-	-	-	-	-	-	80,4
18		-	-	-	-	-	32,5	39,0	45,5	52,0	58,5	65,0	71,5	78,0	84,5	91,0	97,5	101,8	101,8	101,8	101,8	-	-	-	-	101,8
20		-	-	-	-	-	43,4	50,6	57,8	65,0	72,3	79,5	86,7	93,9	101,2	108,4	115,6	125,7	125,7	125,7	125,7	-	-	-	-	125,7
22		-	-	-	-	-	47,7	55,6	63,6	71,5	79,5	87,4	95,4	103,3	111,3	119,2	127,2	143,1	152,1	152,1	152,1	-	-	-	-	152,1
25		-	-	-	-	-	-	63,2	72,3	81,3	90,3	99,4	108,4	117,4	126,4	135,5	144,5	162,6	180,6	180,6	180,6	-	-	-	-	180,6
28		-	-	-	-	-	-	-	80,9	91,0	101,2	111,3	121,4	131,5	141,6	151,7	161,9	182,1	202,3	246,3	246,3	-	-	-	-	246,3
30		-	-	-	-	-	-	-	86,7	97,5	108,4	119,2	130,1	140,9	151,7	162,6	173,4	195,1	216,8	271,0	282,7	282,7	-	-	-	282,7
32		-	-	-	-	-	-	-	-	104,0	115,6	127,2	138,7	150,3	161,9	173,4	185,0	208,1	231,2	289,0	321,7	321,7	321,7	-	-	321,7
34		-	-	-	-	-	-	-	-	110,6	122,8	135,1	147,4	159,7	172,0	184,3	196,5	221,1	245,7	307,1	363,2	363,2	-	-	-	363,2
36		-	-	-	-	-	-	-	-	-	130,1	143,1	156,1	169,1	182,1	195,1	208,1	234,1	260,1	325,2	390,2	407,2	407,2	-	-	407,2
40		-	-	-	-	-	-	-	-	-	-	-	-	150,8	163,4	175,9	188,5	201,1	226,2	251,3	314,2	377,0	502,6	-	-	502,6

ANCHORAGES – DESIGN RESISTANCE – CONCRETE C50/60, NOMINAL YIELD STRENGTH FOR TENSION - $f_{yk} = 460$ [N/mm ²]																											
d_s [mm]	l_{bd} [mm]	200	220	240	260	280	300	325	350	375	400	450	500	550	600	650	700	750	800	900	1000	1250	1500	2000	2500	Steel failure	
8		10,8	13,0	15,1	17,3	19,5	20,1	20,1	20,1	20,1	20,1	-	-	-	-	-	-	-	-	-	-	-	-	-	-	20,1	
10		13,5	16,2	18,9	21,6	24,3	27,0	31,4	31,4	31,4	31,4	31,4	31,4	-	-	-	-	-	-	-	-	-	-	-	-	31,4	
12		-	19,5	22,7	25,9	29,2	32,4	40,5	45,2	45,2	45,2	45,2	45,2	45,2	45,2	-	-	-	-	-	-	-	-	-	-	45,2	
13		-	-	24,6	28,1	31,6	35,1	43,9	52,7	53,1	53,1	53,1	53,1	53,1	53,1	53,1	53,1	-	-	-	-	-	-	-	-	53,1	
14		-	-	26,5	30,3	34,0	37,8	47,3	56,7	61,6	61,6	61,6	61,6	61,6	61,6	61,6	61,6	-	-	-	-	-	-	-	-	61,6	
16		-	-	-	32,2	36,2	40,2	50,3	60,3	70,4	80,4	80,4	80,4	80,4	80,4	80,4	80,4	80,4	80,4	-	-	-	-	-	-	80,4	
18		-	-	-	-	40,7	45,2	56,5	67,9	79,2	90,5	101,8	101,8	101,8	101,8	101,8	101,8	101,8	101,8	101,8	-	-	-	-	-	101,8	
20		-	-	-	-	46,5	58,1	69,7	81,4	93,0	104,6	116,2	127,9	127,9	127,9	127,9	127,9	127,9	127,9	127,9	127,9	-	-	-	-	127,9	
22		-	-	-	-	-	63,9	76,7	89,5	102,3	115,1	127,9	140,6	152,1	152,1	152,1	152,1	152,1	152,1	152,1	152,1	-	-	-	-	152,1	
25		-	-	-	-	-	66,8	80,1	93,5	106,8	120,2	133,5	146,9	160,2	173,6	186,9	196,4	196,4	196,4	196,4	196,4	-	-	-	-	196,4	
28		-	-	-	-	-	-	89,7	104,7	119,6	134,6	149,5	164,5	179,4	194,4	209,4	224,3	239,3	246,3	246,3	246,3	246,3	-	-	-	246,3	
30		-	-	-	-	-	-	-	-	-	-	-	-	-	140,9	151,7	162,6	173,4	195,1	216,8	271,0	307,3	-	-	-	307,33	
32		-	-	-	-	-	-	-	-	-	-	-	-	-	-	161,9	173,4	185,0	208,1	231,2	289,0	346,8	349,7	349,7	-	349,65	
34		-	-	-	-	-	-	-	-	-	-	-	-	-	-	-	184,3	196,5	221,1	245,7	307,1	368,5	394,7	-	-	394,75	
36		-	-	-	-	-	-	-	-	-	-	-	-	-	-	-	-	208,1	234,1	260,1	325,2	390,2	442,6	-	-	442,55	
40		-	-	-	-	-	-	-	-	-	-	-	-	-	-	-	-	-	-	226,2	251,3	314,2	377,0	502,7	-	-	546,35

Basic performance data (cont.)

ANCHORAGES – DESIGN RESISTANCE – CONCRETE C50/60, NOMINAL YIELD STRENGTH FOR TENSION - $f_{yk} = 460$ [N/mm ²]																										
d_s [mm]	l_{bd} [mm]	200	220	240	260	280	300	325	350	375	400	450	500	550	600	650	700	750	800	900	1000	1250	1500	2000	2500	Steel failure
8		-	-	-	-	-	-	-	84,8	99,0	113,1	127,2	141,4	155,5	169,6	183,8	197,9	212,1	226,2	254,5	282,7	282,7	282,7	-	-	282,7
10		-	-	-	-	-	-	-	-	108,6	122,1	135,7	149,3	162,9	176,4	190,0	203,6	217,1	244,3	271,4	321,7	321,7	321,7	321,7	321,7	321,7
12		-	-	-	-	-	-	-	-	115,4	129,8	144,2	158,6	173,0	187,5	201,9	216,3	230,7	259,6	288,4	360,5	363,2	363,2	-	-	363,2
13		-	-	-	-	-	-	-	-	-	-	130,1	143,1	156,1	169,1	182,1	195,1	208,1	234,1	260,1	325,2	390,2	407,2	-	-	407,2
14		-	-	-	-	-	-	-	-	-	-	-	-	150,8	163,4	175,9	188,5	201,1	226,2	251,3	314,2	377,0	502,6	-	-	502,6

OVERLAP SPLICE – DESIGN RESISTANCE – CONCRETE C20/25, NOMINAL YIELD STRENGTH FOR TENSION - $f_{yk} = 460$ [N/mm ²]																										
d_s [mm]	l_{bd} [mm]	200	220	240	260	280	300	325	350	375	400	450	500	550	600	650	700	750	800	900	1000	1250	1500	2000	2500	Steel failure
8		11,6	12,7	13,9	15,0	16,2	17,3	18,8	20,1	20,1	20,1	-	-	-	-	-	-	-	-	-	-	-	-	-	-	20,1
10		14,5	15,9	17,3	18,8	20,2	21,7	23,5	25,3	27,1	28,9	31,4	31,4	-	-	-	-	-	-	-	-	-	-	-	-	31,4
12		-	-	20,8	22,5	24,3	26,0	28,2	30,3	32,5	34,7	39,0	43,4	45,2	45,2	-	-	-	-	-	-	-	-	-	-	45,2
13		-	-	-	24,4	26,3	28,2	30,5	32,9	35,2	37,6	42,3	47,0	51,7	53,1	53,1	53,1	-	-	-	-	-	-	-	-	53,1
14		-	-	-	-	28,3	30,3	32,9	35,4	37,9	40,5	45,5	50,6	55,6	60,7	61,6	61,6	-	-	-	-	-	-	-	-	61,6
16		-	-	-	-	-	-	37,6	40,5	43,4	46,2	52,0	57,8	63,6	69,4	75,1	80,4	80,4	80,4	-	-	-	-	-	-	80,4
18		-	-	-	-	-	-	-	48,8	52,0	58,5	65,0	71,5	78,0	84,5	91,0	97,5	101,8	101,8	101,8	-	-	-	-	-	101,8
20		-	-	-	-	-	-	-	-	57,8	65,0	72,3	79,5	86,7	93,9	101,2	108,4	115,6	125,7	125,7	-	-	-	-	-	125,7
22		-	-	-	-	-	-	-	-	-	71,5	79,5	87,4	95,4	103,3	111,3	119,2	127,2	143,1	152,1	-	-	-	-	-	152,1
25		-	-	-	-	-	-	-	-	-	-	90,3	99,4	108,4	117,4	126,4	135,5	144,5	162,6	180,6	-	-	-	-	-	196,4
28		-	-	-	-	-	-	-	-	-	-	-	111,3	121,4	131,5	141,6	151,7	161,9	182,1	202,3	246,3	-	-	-	-	246,3
30		-	-	-	-	-	-	-	-	-	-	-	-	-	130,1	140,9	151,7	162,6	173,4	195,1	216,8	271,0	282,7	-	-	282,7
32		-	-	-	-	-	-	-	-	-	-	-	-	-	-	150,3	161,9	173,4	185,0	208,1	231,2	289,0	321,7	321,7	321,7	321,7
34		-	-	-	-	-	-	-	-	-	-	-	-	-	-	-	172,0	184,3	196,5	221,1	245,7	307,1	363,2	363,2	-	363,2
36		-	-	-	-	-	-	-	-	-	-	-	-	-	-	-	-	195,1	208,1	234,1	260,1	325,2	390,2	407,2	-	407,2
40		-	-	-	-	-	-	-	-	-	-	-	-	-	-	-	-	-	-	226,2	251,3	314,2	377,0	502,6	-	502,6

OVERLAP SPLICE – DESIGN RESISTANCE – CONCRETE C50/60, NOMINAL YIELD STRENGTH FOR TENSION - $f_{yk} = 460$ [N/mm ²]																										
d_s [mm]	l_{bd} [mm]	200	220	240	260	280	300	325	350	375	400	450	500	550	600	650	700	750	800	900	1000	1250	1500	2000	2500	Steel failure
8		20,1	20,1	20,1	20,1	20,1	20,1	20,1	20,1	20,1	20,1	-	-	-	-	-	-	-	-	-	-	-	-	-	-	20,1
10		27,0	29,7	31,4	31,4	31,4	31,4	31,4	31,4	31,4	31,4	31,4	31,4	-	-	-	-	-	-	-	-	-	-	-	-	31,4
12		32,4	35,7	38,9	42,1	45,2	45,2	45,2	45,2	45,2	45,2	45,2	45,2	45,2	45,2	-	-	-	-	-	-	-	-	-	-	45,2
13		35,1	38,6	42,1	45,7	49,2	52,7	53,1	53,1	53,1	53,1	53,1	53,1	53,1	53,1	53,1	53,1	-	-	-	-	-	-	-	-	53,1
14		-	41,6	45,4	49,2	53,0	56,7	61,5	61,6	61,6	61,6	61,6	61,6	61,6	61,6	61,6	61,6	-	-	-	-	-	-	-	-	61,6
16		-	-	48,3	52,3	56,3	60,3	65,3	70,4	75,4	80,4	80,4	80,4	80,4	80,4	80,4	80,4	80,4	80,4	-	-	-	-	-	-	80,4
18		-	-	-	-	63,3	67,9	73,5	79,2	84,8	90,5	101,8	101,8	101,8	101,8	101,8	101,8	101,8	101,8	101,8	-	-	-	-	-	101,8
20		-	-	-	-	-	69,7	75,6	81,4	87,2	93,0	104,6	116,2	125,7	125,7	125,7	125,7	125,7	125,7	125,7	125,7	125,7	125,7	125,7	125,7	125,7
22		-	-	-	-	-	-	-	-	89,5	95,9	102,3	115,1	127,9	140,6	152,1	152,1	152,1	152,1	152,1	152,1	152,1	152,1	152,1	152,1	152,1
25		-	-	-	-	-	-	-	-	-	100,1	106,8	120,2	133,5	146,9	160,2	173,6	186,9	196,4	196,4	196,4	196,4	196,4	196,4	196,4	196,4
28		-	-	-	-	-	-	-	-	-	-	134,6	149,5	164,5	179,4	194,4	209,4	224,3	239,3	246,3	246,3	246,3	246,3	246,3	246,3	246,3
30		-	-	-	-	-	-	-	-	-	-	127,2	141,4	155,5	169,6	183,8	197,9	212,1	226,2	254,5	282,7	282,7	282,7	282,7	282,7	282,7
32		-	-	-	-	-	-	-	-	-	-	-	-	149,3	162,9	176,4	190,0	203,6	217,1	244,3	271,4	321,7	321,7	321,7	321,7	321,7
34		-	-	-	-	-	-	-	-	-	-	-	-	-	173,0	187,5	201,9	216,3	230,7	259,6	288,4	360,5	363,2	363,2	-	363,2
36		-	-	-	-	-	-	-	-	-	-	-	-	-	-	-	195,1	208,1	234,1	260,1	325,2	390,2	407,2	407,2	-	407,2
40		-	-	-	-	-	-	-	-	-	-	-	-	-	-	-	-	-	-	226,2	251,3	314,2	377,0	502,6	-	502,6

Basic performance data (cont.)

ANCHORAGES – DESIGN RESISTANCE – CONCRETE C20/25, NOMINAL YIELD STRENGTH FOR TENSION - $f_{yk} = 500$ [N/mm ²]																										
d_s [mm]	l_{bd} [mm]	100	120	140	160	180	200	250	300	350	400	450	500	550	600	650	700	750	800	900	1000	1250	1500	2000	2500	Steel failure
8		-	6,9	8,1	9,2	10,4	11,6	14,5	17,3	20,2	21,9	-	-	-	-	-	-	-	-	-	-	-	-	-	-	21,9
10		-	-	-	11,6	13,0	14,5	18,1	21,7	25,3	28,9	32,5	34,1	-	-	-	-	-	-	-	-	-	-	-	-	34,1
12		-	-	-	-	15,6	17,3	21,7	26,0	30,3	34,7	39,0	43,4	47,7	49,2	-	-	-	-	-	-	-	-	-	-	49,2
13		-	-	-	-	-	18,8	23,5	28,2	32,9	37,6	42,3	47,0	51,7	56,4	57,7	57,7	-	-	-	-	-	-	-	-	57,7
14		-	-	-	-	-	20,2	25,3	30,3	35,4	40,5	45,5	50,6	55,6	60,7	65,8	66,9	-	-	-	-	-	-	-	-	66,9
16		-	-	-	-	-	-	28,9	34,7	40,5	46,2	52,0	57,8	63,6	69,4	75,1	80,9	86,7	87,4	-	-	-	-	-	-	87,4
18		-	-	-	-	-	-	-	39,0	45,5	52,0	58,5	65,0	71,5	78,0	84,5	91,0	97,5	104,0	110,6	-	-	-	-	-	110,6
20		-	-	-	-	-	-	-	43,4	50,6	57,8	65,0	72,3	79,5	86,7	93,9	101,2	108,4	115,6	130,1	136,6	-	-	-	-	136,6
22		-	-	-	-	-	-	-	-	55,6	63,6	71,5	79,5	87,4	95,4	103,3	111,3	119,2	127,2	143,1	159,0	-	-	-	-	165,3
25		-	-	-	-	-	-	-	-	-	72,3	81,3	90,3	99,4	108,4	117,4	126,4	135,5	144,5	162,6	180,6	-	-	-	-	213,4
28		-	-	-	-	-	-	-	-	-	80,9	91,0	101,2	111,3	121,4	131,5	141,6	151,7	161,9	182,1	202,3	252,9	-	-	-	267,7
30		-	-	-	-	-	-	-	-	-	-	97,5	108,4	119,2	130,1	140,9	151,7	162,6	173,4	195,1	216,8	271,0	307,3	-	-	307,3
32		-	-	-	-	-	-	-	-	-	-	-	115,6	127,2	138,7	150,3	161,9	173,4	185,0	208,1	231,2	289,0	346,8	349,7	349,7	349,7
34		-	-	-	-	-	-	-	-	-	-	-	122,8	135,1	147,4	159,7	172,0	184,3	196,5	221,1	245,7	307,1	368,5	394,7	-	394,7
36		-	-	-	-	-	-	-	-	-	-	-	-	143,1	156,1	169,1	182,1	195,1	208,1	234,1	260,1	325,2	390,2	442,6	-	442,6
40		-	-	-	-	-	-	-	-	-	-	-	-	-	150,8	163,4	175,9	188,5	201,1	226,2	251,3	314,2	377,0	502,7	-	546,3

ANCHORAGES – DESIGN RESISTANCE – CONCRETE C50/60, NOMINAL YIELD STRENGTH FOR TENSION - $f_{yk} = 500$ [N/mm ²]																										
d_s [mm]	l_{bd} [mm]	100	120	140	160	180	200	250	300	350	400	450	500	550	600	650	700	750	800	900	1000	1250	1500	2000	2500	Steel failure
8		10,8	13,0	15,1	17,3	19,5	21,6	21,9	21,9	21,9	21,9	-	-	-	-	-	-	-	-	-	-	-	-	-	-	21,9
10		13,5	16,2	18,9	21,6	24,3	27,0	33,8	34,1	34,1	34,1	34,1	34,1	-	-	-	-	-	-	-	-	-	-	-	-	34,1
12		-	19,5	22,7	25,9	29,2	32,4	40,5	48,6	49,2	49,2	49,2	49,2	49,2	-	-	-	-	-	-	-	-	-	-	-	49,2
13		-	-	24,6	28,1	31,6	35,1	43,9	52,7	57,7	57,7	57,7	57,7	57,7	57,7	57,7	-	-	-	-	-	-	-	-	-	57,7
14		-	-	26,5	30,3	34,0	37,8	47,3	56,7	66,2	66,9	66,9	66,9	66,9	66,9	66,9	-	-	-	-	-	-	-	-	-	66,9
16		-	-	-	32,2	36,2	40,2	50,3	60,3	70,4	80,4	87,4	87,4	87,4	87,4	87,4	87,4	87,4	87,4	-	-	-	-	-	-	87,4
18		-	-	-	-	40,7	45,2	56,5	67,9	79,2	90,5	101,8	110,6	110,6	110,6	110,6	110,6	110,6	110,6	110,6	-	-	-	-	-	110,6
20		-	-	-	-	-	46,5	58,1	69,7	81,4	93,0	104,6	116,2	127,9	136,6	136,6	136,6	136,6	136,6	136,6	136,6	136,6	-	-	-	136,6
22		-	-	-	-	-	-	63,9	76,7	89,5	102,3	115,1	127,9	140,6	153,4	165,3	165,3	165,3	165,3	165,3	165,3	165,3	-	-	-	165,3
25		-	-	-	-	-	-	66,8	80,1	93,5	106,8	120,2	133,5	146,9	160,2	173,6	186,9	200,3	213,4	213,4	213,4	-	-	-	-	213,4
28		-	-	-	-	-	-	-	89,7	104,7	119,6	134,6	149,5	164,5	179,4	194,4	209,4	224,3	239,3	267,7	267,7	267,7	-	-	-	267,7
30		-	-	-	-	-	-	-	-	99,0	113,1	127,2	141,4	155,5	169,6	183,8	197,9	212,1	226,2	254,5	282,7	307,3	307,3	-	-	307,3
32		-	-	-	-	-	-	-	-	-	108,6	122,1	135,7	149,3	162,9	176,4	190,0	203,6	217,1	244,3	271,4	339,3	349,7	349,7	349,7	349,7
34		-	-	-	-	-	-	-	-	-	-	129,8	144,2	158,6	173,0	187,5	201,9	216,3	230,7	259,6	288,4	360,5	394,7	394,7	-	394,7
36		-	-	-	-	-	-	-	-	-	-	-	-	143,1	156,1	169,1	182,1	195,1	208,1	234,1	260,1	325,2	390,2	442,6	-	442,6
40		-	-	-	-	-	-	-	-	-	-	-	-	-	150,8	163,4	175,9	188,5	201,1	226,2	251,3	314,2	377,0	502,7	-	546,3

OVERLAP SPLICE – DESIGN RESISTANCE – CONCRETE C20/25, NOMINAL YIELD STRENGTH FOR TENSION - $f_{yk} = 500$ [N/mm ²]																										
d_s [mm]	l_{bd} [mm]	200	220	240	260	280	300	325	350	375	400	450	500	550	600	650	700	750	800	900	1000	1250	1500	2000	2500	Steel failure
8		11,6	12,7	13,9	15,0	16,2	17,3	18,8	20,2	21,7	21,9	-	-	-	-	-	-	-	-	-	-	-	-	-	-	21,9
10		-	15,9	17,3	18,8	20,2	21,7	23,5	25,3	27,1	28,9	32,5	34,1	-	-	-	-	-	-	-	-	-	-	-	-	34,1
12		-	-	-	22,5	24,3	26,0	28,2	30,3	32,5	34,7	39,0	43,4	47,7	49,2	-	-	-	-	-	-	-	-	-	-	49,2
13		-	-	-	-	26,3	28,2	30,5	32,9	35,2	37,6	42,3	47,0	51,7	56,4	57,7	57,7	-	-	-	-	-	-	-	-	57,7
14		-	-	-	-	-	30,3	32,9	35,4	37,9	40,5	45,5	50,6	55,6	60,7	65,8	66,9	-	-	-	-	-	-	-	-	66,9
16		-	-	-	-	-	-	-	40,5	43,4	46,2	52,0	57,8	63,6	69,4	75,1	80,9	86,7	87,4	-	-	-	-	-	-	87,4
18		-	-	-	-	-	-	-	-	-	52,0	58,5	65,0	71,5	78,0	84,5	91,0	97,5	104,0	110,6	-	-	-	-	-	110,6
20		-	-	-	-	-	-	-	-	-	-	65,0	72,3	79,5	86,7	93,9	101,2	108,4	115,6	130,1	136,6	-	-	-	-	136,6
22		-	-	-	-	-	-	-	-	-	-	-	79,5	87,4	95,4	103,3	111,3	119,2	127,2	143,1	159,0	-	-	-	-	165,3
25		-	-	-	-	-	-	-	-	-	-	-	-	99,4	108,4	117,4	126,4	135,5	144,5	162,6	180,6	-	-	-	-	213,4
28		-	-	-	-	-	-	-	-	-	-	-	-	-	121,4	131,5	141,6	151,7	161,9	182,1	202,3	252,9	-	-	-	267,7
30		-	-	-	-	-	-	-	-	-	-	-	-	-	-	140,9	151,7	162,6	173,4	195,1	216,8	271,0	307,3	-	-	307,3
32		-	-	-	-	-	-	-	-	-	-	-	-	-	-	-	161,9	173,4	185,0	208,1	231,2	289,0	346,8	349,7	349,7	349,7
34		-	-	-	-	-	-	-	-	-	-	-	-	-	-	-	-	184,3	196,5	221,1	245,7	307,1	368,5	394,7	-	394,7
36		-	-	-	-	-	-	-	-	-	-	-	-	-	-	-	-	-	208,1	234,1	260,1	325,2	390,2	442,6	-	442,6
40		-	-	-	-	-	-	-	-	-	-	-	-	-	-	-	-	-	-	226,2	251,3	314,2	377,0	502,7	-	546,3

Basic performance data (cont.)

OVERLAP SPLICE – DESIGN RESISTANCE – CONCRETE C50/60, NOMINAL YIELD STRENGTH FOR TENSION - $f_{yk} = 500$ [N/mm ²]																										
d_s [mm]	l_{bd} [mm]	200	220	240	260	280	300	325	350	375	400	450	500	550	600	650	700	750	800	900	1000	1250	1500	2000	2500	Steel failure
8		21,6	21,9	21,9	21,9	21,9	21,9	21,9	21,9	21,9	-	-	-	-	-	-	-	-	-	-	-	-	-	-	-	21,9
10		27,0	29,7	32,4	34,1	34,1	34,1	34,1	34,1	34,1	34,1	34,1	34,1	-	-	-	-	-	-	-	-	-	-	-	-	34,1
12		32,4	35,7	38,9	42,1	45,4	48,6	49,2	49,2	49,2	49,2	49,2	49,2	49,2	49,2	-	-	-	-	-	-	-	-	-	-	49,2
13		35,1	38,6	42,1	45,7	49,2	52,7	57,1	57,7	57,7	57,7	57,7	57,7	57,7	57,7	57,7	-	-	-	-	-	-	-	-	-	57,7
14		-	41,6	45,4	49,2	53,0	56,7	61,5	66,2	66,9	66,9	66,9	66,9	66,9	66,9	66,9	66,9	-	-	-	-	-	-	-	-	66,9
16		-	-	48,3	52,3	56,3	60,3	65,3	70,4	75,4	80,4	87,4	87,4	87,4	87,4	87,4	87,4	87,4	87,4	-	-	-	-	-	-	87,4
18		-	-	-	-	63,3	67,9	73,5	79,2	84,8	90,5	101,8	110,6	110,6	110,6	110,6	110,6	110,6	110,6	110,6	110,6	-	-	-	-	110,6
20		-	-	-	-	-	69,7	75,6	81,4	87,2	93,0	104,6	116,2	127,9	136,6	136,6	136,6	136,6	136,6	136,6	136,6	136,6	-	-	-	136,6
22		-	-	-	-	-	-	-	89,5	95,9	102,3	115,1	127,9	140,6	153,4	165,3	165,3	165,3	165,3	165,3	165,3	165,3	-	-	-	165,3
25		-	-	-	-	-	-	-	-	100,1	106,8	120,2	133,5	146,9	160,2	173,6	186,9	200,3	213,4	213,4	213,4	-	-	-	-	213,4
28		-	-	-	-	-	-	-	-	-	-	134,6	149,5	164,5	179,4	194,4	209,4	224,3	239,3	267,7	267,7	267,7	-	-	-	267,7
30		-	-	-	-	-	-	-	-	-	-	-	141,4	155,5	169,6	183,8	197,9	212,1	226,2	254,5	282,7	307,3	307,3	-	-	307,3
32		-	-	-	-	-	-	-	-	-	-	-	-	162,9	176,4	190,0	203,6	217,1	244,3	271,4	339,3	349,7	349,7	349,7	-	349,7
34		-	-	-	-	-	-	-	-	-	-	-	-	-	187,5	201,9	216,3	230,7	259,6	288,4	360,5	394,7	394,7	-	-	394,7
36		-	-	-	-	-	-	-	-	-	-	-	-	-	-	-	-	208,1	234,1	260,1	325,2	390,2	442,6	-	-	442,6
40		-	-	-	-	-	-	-	-	-	-	-	-	-	-	-	-	-	-	226,2	251,3	314,2	377,0	502,7	-	546,3

ANCHORAGES – DESIGN RESISTANCE – CONCRETE C20/25, NOMINAL YIELD STRENGTH FOR TENSION - $f_{yk} = 600$ [N/mm ²]																										
d_s [mm]	l_{bd} [mm]	200	220	240	260	280	300	325	350	375	400	450	500	550	600	650	700	750	800	900	1000	1250	1500	2000	2500	Steel failure
8		-	-	8,1	9,2	10,4	11,6	14,5	17,3	20,2	23,1	-	-	-	-	-	-	-	-	-	-	-	-	-	-	26,2
10		-	-	-	-	13,0	14,5	18,1	21,7	25,3	28,9	32,5	36,1	-	-	-	-	-	-	-	-	-	-	-	-	41,0
12		-	-	-	-	-	21,7	26,0	30,3	34,7	39,0	43,4	47,7	52,0	-	-	-	-	-	-	-	-	-	-	-	59,0
13		-	-	-	-	-	-	23,5	28,2	32,9	37,6	42,3	47,0	51,7	56,4	61,1	65,8	-	-	-	-	-	-	-	-	69,3
14		-	-	-	-	-	-	25,3	30,3	35,4	40,5	45,5	50,6	55,6	60,7	65,8	70,8	-	-	-	-	-	-	-	-	80,3
16		-	-	-	-	-	-	-	34,7	40,5	46,2	52,0	57,8	63,6	69,4	75,1	80,9	86,7	92,5	-	-	-	-	-	-	104,9
18		-	-	-	-	-	-	-	-	45,5	52,0	58,5	65,0	71,5	78,0	84,5	91,0	97,5	104,0	117,1	-	-	-	-	-	132,8
20		-	-	-	-	-	-	-	-	50,6	57,8	65,0	72,3	79,5	86,7	93,9	101,2	108,4	115,6	130,1	144,5	-	-	-	-	163,9
22		-	-	-	-	-	-	-	-	-	63,6	71,5	79,5	87,4	95,4	103,3	111,3	119,2	127,2	143,1	159,0	-	-	-	-	198,3
25		-	-	-	-	-	-	-	-	-	-	81,3	90,3	99,4	108,4	117,4	126,4	135,5	144,5	162,6	180,6	-	-	-	-	256,1
28		-	-	-	-	-	-	-	-	-	-	-	101,2	111,3	121,4	131,5	141,6	151,7	161,9	182,1	202,3	252,9	-	-	-	321,3
30		-	-	-	-	-	-	-	-	-	-	-	-	119,2	130,1	140,9	151,7	162,6	173,4	195,1	216,8	271,0	325,2	-	-	368,8
32		-	-	-	-	-	-	-	-	-	-	-	-	-	127,2	138,7	150,3	161,9	173,4	185,0	208,1	231,2	289,0	346,8	419,6	419,6
34		-	-	-	-	-	-	-	-	-	-	-	-	-	-	147,4	159,7	172,0	184,3	196,5	221,1	245,7	307,1	368,5	473,7	473,7
36		-	-	-	-	-	-	-	-	-	-	-	-	-	-	-	169,1	182,1	195,1	208,1	234,1	260,1	325,2	390,2	520,2	531,1
40		-	-	-	-	-	-	-	-	-	-	-	-	-	-	-	-	-	188,5	201,1	226,2	251,3	314,2	377,0	502,7	655,6

ANCHORAGES – DESIGN RESISTANCE – CONCRETE C50/60, NOMINAL YIELD STRENGTH FOR TENSION - $f_{yk} = 600$ [N/mm ²]																										
d_s [mm]	l_{bd} [mm]	200	220	240	260	280	300	325	350	375	400	450	500	550	600	650	700	750	800	900	1000	1250	1500	2000	2500	Steel failure
8		10,8	13,0	15,1	17,3	19,5	21,6	26,2	26,2	26,2	26,2	-	-	-	-	-	-	-	-	-	-	-	-	-	-	26,2
10		13,5	16,2	18,9	21,6	24,3	27,0	33,8	40,5	41,0	41,0	41,0	41,0	-	-	-	-	-	-	-	-	-	-	-	-	41,0
12		-	19,5	22,7	25,9	29,2	32,4	40,5	48,6	56,7	59,0	59,0	59,0	59,0	59,0	-	-	-	-	-	-	-	-	-	-	59,0
13		-	-	24,6	28,1	31,6	35,1	43,9	52,7	61,5	69,3	69,3	69,3	69,3	69,3	69,3	-	-	-	-	-	-	-	-	-	69,3
14		-	-	26,5	30,3	34,0	37,8	47,3	56,7	66,2	75,6	80,3	80,3	80,3	80,3	80,3	80,3	-	-	-	-	-	-	-	-	80,3
16		-	-	-	32,2	36,2	40,2	50,3	60,3	70,4	80,4	90,5	100,5	104,9	104,9	104,9	104,9	104,9	104,9	-	-	-	-	-	-	104,9
18		-	-	-	-	40,7	45,2	56,5	67,9	79,2	90,5	101,8	113,1	124,4	132,8	132,8	132,8	132,8	132,8	132,8	-	-	-	-	-	132,8
20		-	-	-	-	-	-	58,1	69,7	81,4	93,0	104,6	116,2	127,9	139,5	151,1	162,7	163,9	163,9	163,9	163,9	-	-	-	-	163,9
22		-	-	-	-	-	-	-	63,9	76,7	89,5	102,3	115,1	127,9	140,6	153,4	166,2	179,0	191,8	198,3	198,3	198,3	-	-	-	198,3
25		-	-	-	-	-	-	-	-	80,1	93,5	106,8	120,2	133,5	146,9	160,2	173,6	186,9	200,3	213,6	240,3	256,1	-	-	-	256,1
28		-	-	-	-	-	-	-	-	-	104,7	119,6	134,6	149,5	164,5	179,4	194,4	209,4	224,3	239,3	269,2	299,1	321,3	-	-	321,3
30		-	-	-	-	-	-	-	-	-	113,1	127,2	141,4	155,5	169,6	183,8	197,9	212,1	226,2	254,5	282,7	353,4	368,8	-	-	368,8
32		-	-	-	-	-	-	-	-	-	-	-	135,7	149,3	162,9	176,4	190,0	203,6	217,1	244,3	271,4	339,3	407,2	419,6	419,6	419,6
34		-	-	-	-	-	-	-	-	-	-	-	-	144,2	158,6	173,0	187,5	201,9	216,3	230,7	259,6	288,4	360,5	432,6	473,7	473,7
36		-	-	-	-	-	-	-	-	-	-	-	-	-	-	169,1	182,1	195,1	208,1	234,1	260,1	325,2	390,2	520,2	-	531,1
40		-	-	-	-	-	-	-	-	-	-	-	-	-	-	-	-	188,5	201,1	226,2	251,3	314,2	377,0	502,7	-	655,6

Basic performance data (cont.)

OVERLAP SPLICE – DESIGN RESISTANCE – CONCRETE C20/25, NOMINAL YIELD STRENGTH FOR TENSION - $f_{yk} = 600$ [N/mm ²]																										
d_s [mm]	l_{bd} [mm]	100	120	140	160	180	200	250	300	350	400	450	500	550	600	650	700	750	800	900	1000	1250	1500	2000	2500	Steel failure
8	-	12,7	13,9	15,0	16,2	17,3	18,8	20,2	21,7	23,1	-	-	-	-	-	-	-	-	-	-	-	-	-	-	-	26,2
10	-	-	-	18,8	20,2	21,7	23,5	25,3	27,1	28,9	32,5	36,1	-	-	-	-	-	-	-	-	-	-	-	-	-	41,0
12	-	-	-	-	-	-	28,2	30,3	32,5	34,7	39,0	43,4	47,7	52,0	-	-	-	-	-	-	-	-	-	-	-	59,0
13	-	-	-	-	-	-	-	32,9	35,2	37,6	42,3	47,0	51,7	56,4	61,1	65,8	-	-	-	-	-	-	-	-	-	69,3
14	-	-	-	-	-	-	-	-	37,9	40,5	45,5	50,6	55,6	60,7	65,8	70,8	-	-	-	-	-	-	-	-	-	80,3
16	-	-	-	-	-	-	-	-	-	-	52,0	57,8	63,6	69,4	75,1	80,9	86,7	92,5	-	-	-	-	-	-	-	104,9
18	-	-	-	-	-	-	-	-	-	-	-	65,0	71,5	78,0	84,5	91,0	97,5	104,0	117,1	-	-	-	-	-	-	132,8
20	-	-	-	-	-	-	-	-	-	-	-	-	79,5	86,7	93,9	101,2	108,4	115,6	130,1	144,5	-	-	-	-	-	163,9
22	-	-	-	-	-	-	-	-	-	-	-	-	-	95,4	103,3	111,3	119,2	127,2	143,1	159,0	-	-	-	-	-	198,3
25	-	-	-	-	-	-	-	-	-	-	-	-	-	-	117,4	126,4	135,5	144,5	162,6	180,6	-	-	-	-	-	256,1
28	-	-	-	-	-	-	-	-	-	-	-	-	-	-	-	-	151,7	161,9	182,1	202,3	252,9	-	-	-	-	321,3
30	-	-	-	-	-	-	-	-	-	-	-	-	-	-	-	-	-	173,4	195,1	216,8	271,0	325,2	-	-	-	368,8
32	-	-	-	-	-	-	-	-	-	-	-	-	-	-	-	-	-	-	208,1	231,2	289,0	346,8	419,6	419,6	-	419,6
34	-	-	-	-	-	-	-	-	-	-	-	-	-	-	-	-	-	-	-	221,1	245,7	307,1	368,5	473,7	-	473,7
36	-	-	-	-	-	-	-	-	-	-	-	-	-	-	-	-	-	-	-	-	260,1	325,2	390,2	520,2	-	531,1
40	-	-	-	-	-	-	-	-	-	-	-	-	-	-	-	-	-	-	-	-	-	314,2	377,0	502,7	-	655,6

OVERLAP SPLICE – DESIGN RESISTANCE – CONCRETE C50/60, NOMINAL YIELD STRENGTH FOR TENSION - $f_{yk} = 600$ [N/mm ²]																										
d_s [mm]	l_{bd} [mm]	100	120	140	160	180	200	250	300	350	400	450	500	550	600	650	700	750	800	900	1000	1250	1500	2000	2500	Steel failure
8	21,6	23,8	25,9	26,2	26,2	26,2	26,2	26,2	26,2	26,2	-	-	-	-	-	-	-	-	-	-	-	-	-	-	-	26,2
10	27,0	29,7	32,4	35,1	37,8	40,5	41,0	41,0	41,0	41,0	41,0	41,0	-	-	-	-	-	-	-	-	-	-	-	-	-	41,0
12	32,4	35,7	38,9	42,1	45,4	48,6	52,7	56,7	59,0	59,0	59,0	59,0	59,0	59,0	-	-	-	-	-	-	-	-	-	-	-	59,0
13	35,1	38,6	42,1	45,7	49,2	52,7	57,1	61,5	65,9	69,3	69,3	69,3	69,3	69,3	69,3	69,3	-	-	-	-	-	-	-	-	-	69,3
14	-	41,6	45,4	49,2	53,0	56,7	61,5	66,2	70,9	75,6	80,3	80,3	80,3	80,3	80,3	80,3	-	-	-	-	-	-	-	-	-	80,3
16	-	-	48,3	52,3	56,3	60,3	65,3	70,4	75,4	80,4	90,5	100,5	104,9	104,9	104,9	104,9	104,9	104,9	-	-	-	-	-	-	-	104,9
18	-	-	-	-	63,3	67,9	73,5	79,2	84,8	90,5	101,8	113,1	124,4	132,8	132,8	132,8	132,8	132,8	132,8	132,8	-	-	-	-	-	132,8
20	-	-	-	-	-	75,6	81,4	87,2	93,0	104,6	116,2	127,9	139,5	151,1	162,7	163,9	163,9	163,9	163,9	163,9	163,9	-	-	-	-	163,9
22	-	-	-	-	-	-	-	89,5	95,9	102,3	115,1	127,9	140,6	153,4	166,2	179,0	191,8	198,3	198,3	198,3	198,3	-	-	-	-	198,3
25	-	-	-	-	-	-	-	-	-	-	120,2	133,5	146,9	160,2	173,6	186,9	200,3	213,6	240,3	256,1	-	-	-	-	-	256,1
28	-	-	-	-	-	-	-	-	-	-	-	149,5	164,5	179,4	194,4	209,4	224,3	239,3	269,2	299,1	321,3	-	-	-	-	321,3
30	-	-	-	-	-	-	-	-	-	-	-	-	-	-	169,6	183,8	197,9	212,1	226,2	254,5	282,7	353,4	368,8	-	-	368,8
32	-	-	-	-	-	-	-	-	-	-	-	-	-	-	-	-	190,0	203,6	217,1	244,3	271,4	339,3	407,2	419,6	419,6	419,6
34	-	-	-	-	-	-	-	-	-	-	-	-	-	-	-	-	-	216,3	230,7	259,6	288,4	360,5	432,6	473,7	-	473,7
36	-	-	-	-	-	-	-	-	-	-	-	-	-	-	-	-	-	-	-	-	260,1	325,2	390,2	520,2	-	531,1
40	-	-	-	-	-	-	-	-	-	-	-	-	-	-	-	-	-	-	-	-	-	314,2	377,0	502,7	-	655,6

Product commercial data

Product Code	Volume [m]	Quantity [pcs]			Weight [kg]			Bar Code
		Box	Outer	Pallet	Box	Outer	Pallet	
R-KEX-II-385	385	10	10	380	6.7	6.7	285.0	5906675028538
R-KEX-II-600	600	7	7	441	7.0	7.0	472.7	5906675293721

R-KER II

Hybrid
bonded anchor



RIGHTS



EXTENSIVE CERTIFICATATION

The R-KER II has been designed for professionals, and in order to satisfy their needs, it was tested to confirm its top class parameters. The following certificates have been consequently obtained: ETA, C1 validating the use of the R-KER II anchor in seismic territories, and certificates verifying its fire resistance, electric conductivity and content of VOC (volatile organic compounds). This is what makes the R-KER II perfect for application in severe operating conditions.

COMPLETE SYSTEM ENSURING SAFE FIXING

The innovative formula of the resin has made it possible to achieve some of the highest load capacity in the group of hybrid resins. R-KERII ensures the highest safety level of anchor fasteners thanks to improvement and acceleration of the hole preparation process. Using Dustless Drill with automatic suction drilling and cleaning the holes you do at the same time. Thanks to this, you achieve optimal preparation of the anchoring hole and save time needed to prepare the hole.

EXTRAORDINARY STRENGTH

The special resin formulation allows achieve one of the best load capacity in relation to similar resins on the market.

EASE OF USE

The R-KER II anchors can be applied in a hole without cleaning, by means of the Dustless Drill Bit – which it provides

- Drilling and cleaning holes at one time
- Optimal preparation of the anchoring hole
- Saves time needed to prepare the hole
- Eliminating the risk associated with exposure to dust, reducing harmful dust.



What becomes a requirement on construction sites in an increasing number of countries (eg OSHA recommendation in the USA or HSE in Great Britain).

R-KER II



HYBRID BONDED ANCHOR

Efficiency and comfort of use, high technical parameters confirmed by recognised certificates and a wide range of applications with different rod types guarantee durable and secure anchoring. It is the needs of our clients that inspired us to develop the R-KER II.



Durability and strength



Extensive certification:
ETA, C1, VOC, R240,
Electric Resistivity



Wide range of connectors with many sizes and anti-corrosive variants **ZP, HGD, ZF, UHS ZF, A2, A4, HCR**

Comfortable work and better efficiency
Using in fixing Dustless Drill - you can save up to 40% of the time on resin applications



Easy installation thanks to a dedicated nozzle with scale on the mixer, providing accurate injection of resin



High resistance in a variety of corrosive environments (**C1-C5**)



Three resin versions:
standard
summer
winter



Dustless Drill - accelerated installation time due to simplified procedure - just drill the hole and apply system thanks to the automatic extraction of the output

Convenient working conditions – 3 options of hole preparation:

automatic cleaning using hollow drillbit, traditional method with brush, cleaning with compressed air





Thanks to the special formulation, resin fills all voids in the hole, while improved adhesion and even distribution of forces additionally ensure durable and reliable fixing.

INSTALLATION GUIDE

Fix it comfortably



Apply a new and innovative drilling method using our special dustless drill bit. Rawlplug's hollow Dustlessdrill bit makes every installation easier, cleaner and more durable.



Drilling with automatic cleaning with the hollow Dustlessdrill bit

Traditional method – using blowpump and brush (4x, 4x, 4x)

Cleaning with compressed air (2x, 2x, 2x)

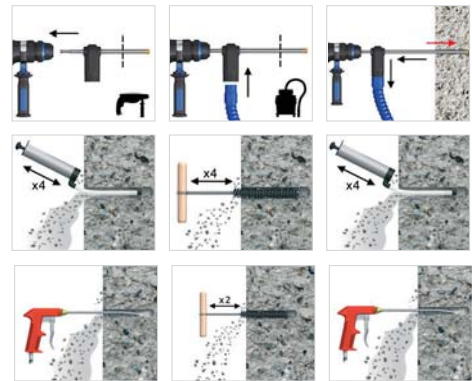

R-KER II anchor



1. Drill a hole to the right diameter and depth.
2. Insert a cartridge into the gun and attach a mixing nozzle.
3. When using a new cartridge, discard some part of resin until you obtain uniform colour of mixture.
4. Fill the hole with resin up to 70% of its volume starting from its far end.
5. Once you have dosed the resin, immediately insert a rod into the hole in a twisting motion. Remove any excess of resin that has escaped the hole and leave it undisturbed until it cures.
6. Attach the fixture and tighten the nut to the required torque.

R-KER-II Hybrid resin with Threaded Rods

High strength and versatile application in cracked and non-cracked concrete with threaded rods



Installation movie



Approvals and Reports

• ETA-17/0594

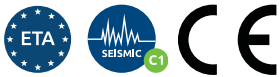

Product overview

Features and benefits

- Approved for use with threaded rods for use in cracked and non-cracked concrete
- Suitable for use in dry and wet substrates as well as holes and substrates covered with water
- Rapid bonding time enables quick execution of works
- For faster curing can be used winter version of the resin
- Special nozzle with longer mixer for more comfortable and precise application
- Suitable for multiple use. Partly used product can be reused after fitting new nozzle
- Very high load capacity
- Seismic category C1
- Three methods for preparing core holes, including automatic Dustless Drill

Applications

- Curtain walling
- Balustrading
- Handrails
- Canopies
- Cable conduits and trays
- Fencing & gates manufacturing and installation
- Pipework/ductwork supports
- Platforms
- Pipelines systems
- Passenger lifts

Base materials

Approved for use in:

- Cracked concrete C20/25-C50/60
- Non-cracked concrete C20/25-C50/60

Installation guide



Installation guide (cont.)

1. Drill hole to the required diameter and depth using a hollow Dustless Drill bit with vacuum cleaner.
2. Insert cartridge into gun and attach nozzle.
3. Dispense to waste until even colour is obtained (min. 10 cm).
4. Insert the mixer nozzle to the bottom of the drill hole and inject resin, slowly withdrawing the nozzle as the hole is filled to 70% of its depth.
5. Immediately insert the stud, slowly and with slight twisting motion. Remove any excess resin around the hole before it sets and leave it undisturbed until the curing time elapses.
6. Attach fixture and tighten the nut to the required torque.

Product information

Product Code	Resin	Description / Resin Type	Volume
			[ml]
R-KER-II-300	R-KER-II	R-KER II Hybrid Resin	300
R-KER-II-345			345
R-KER-II-400			400
R-KER-II-300-S	R-KER-II-S	R-KER II Hybrid Resin for High Temperature (Summer) / Slow Cure Styrene Free Hybrid Resin	300
R-KER-II-400-S			400
R-KER-II-300-W	R-KER-II-W	R-KER II Hybrid Resin for Low Temperature (Winter) / Rapid Cure Styrene Free Hybrid Resin	300
R-KER-II-345-W			345
R-KER-II-400-W			400

R-STUDS

Size	Product Code			Anchor		Fixture		
	Steel class 5.8	Steel class 8.8	Steel grade A4	Diameter	Length	Hole diameter	Max. thickness _{t_{fix}} for:	
				d	L	d _r	h _{nom, min}	h _{nom, max}
				[mm]	[mm]	[mm]	[mm]	[mm]
M8	R-STUDS-08110	R-STUDS-08110-88	R-STUDS-08110-A4	8	110	9	40	-
	R-STUDS-08160	-	R-STUDS-08160-A4*	8	160	9	90	-
M10	R-STUDS-10130	R-STUDS-10130-88	R-STUDS-10130-A4	10	130	12	58	-
	R-STUDS-10170	-	R-STUDS-10170-A4*	10	170	12	98	-
	R-STUDS-10190	-	R-STUDS-10190-A4*	10	190	12	118	-
M12	R-STUDS-12160	R-STUDS-12160-88	R-STUDS-12160-A4	12	160	14	85	-
	R-STUDS-12190	-	R-STUDS-12190-A4*	12	190	14	115	-
	R-STUDS-12220	-	R-STUDS-12220-A4*	12	220	14	145	-
	R-STUDS-12260	-	R-STUDS-12260-A4*	12	260	14	185	-
M16	R-STUDS-12300	-	R-STUDS-12300-A4*	12	300	14	225	45
	R-STUDS-16190	R-STUDS-16190-88	R-STUDS-16190-A4	16	190	18	111	-
	R-STUDS-16220	R-STUDS-16220-88	R-STUDS-16220-A4*	16	220	18	141	-
	R-STUDS-16260	-	R-STUDS-16260-A4*	16	260	18	181	-
	R-STUDS-16300	-	R-STUDS-16300-A4*	16	300	18	221	-
M20	R-STUDS-16380	-	R-STUDS-16380-A4*	16	380	18	301	41
	R-STUDS-20260	R-STUDS-20260-88	R-STUDS-20260-A4	20	260	22	157	-
	R-STUDS-20300	R-STUDS-20300-88	R-STUDS-20300-A4*	20	300	22	197	-
M24	R-STUDS-20350	-	R-STUDS-20350-A4*	20	350	22	247	-
	R-STUDS-24300	R-STUDS-24300-88	R-STUDS-24300-A4*	24	300	26	176	-
M30	R-STUDS-30380	R-STUDS-30380-88	R-STUDS-30380-A4	30	380	32	226	-

* Make to order

Installation data

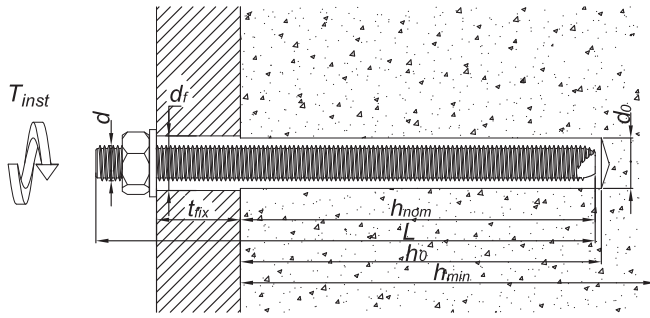

R-STUDS

Size			M8	M10	M12	M16	M20	M24	M30
Thread diameter	d	[mm]	8	10	12	16	20	24	30
Hole diameter in substrate	d ₀	[mm]	10	12	14	18	24	28	35
Hole diameter in fixture	d _f	[mm]	9	12	14	18	22	26	32
Min. hole depth in substrate	h ₀	[mm]	h _{nom} + 5	h _{nom} + 5	h _{nom} + 5	h _{nom} + 5	h _{nom} + 5	h _{nom} + 5	h _{nom} + 5
Min. substrate thickness	h _{min}	[mm]	h _{nom} + 30 ≥ 100	h _{nom} + 30 ≥ 100	h _{nom} + 30 ≥ 100	h _{nom} + 2d ₀	h _{nom} + 2d ₀	h _{nom} + 2d ₀	h _{nom} + 2d ₀
Installation torque	T _{inst}	[Nm]	10	20	40	80	120	160	200
Min. spacing	s _{min}	[mm]	40	40	40	40	40	50	60
Min. edge distance	s _{min}	[mm]	40	40	40	40	40	50	60
MINIMUM EMBEDMENT DEPTH									
Installation depth	h _{nom, min}	[mm]	60	60	60	60	80	96	120
MAXIMUM EMBEDMENT DEPTH									
Installation depth	h _{nom, max}	[mm]	160	200	240	320	400	480	600

Minimum working and curing time

Resin temperature °C	Concrete temperature °C	Working time [min]			Curing time* [min.]		
		R-KER-II	R-KER-II S	R-KER-II W	R-KER-II	R-KER-II S	R-KER-II W
5	0	30	-	14	3 h	-	2h
5	5	15	40	9	90	12h	60
10	10	8	20	5.5	60	8h	45
15	15	5	15	3	60	6h	30
20	20	2.5	10	2	45	4h	15
25	25	2	9.5	1.5	45	3h	10
25	30	2	7	1.5	45	2h	10
25	35	1.5	6.5	1	30	2h	5
25	40	1.5	6.5	1	30	1.5h	5

*For wet concrete the curing time must be doubled

Mechanical properties

R-STUDS

Size			M8	M10	M12	M16	M20	M24	M30
R-STUDS METRIC THREADED RODS - steel class 5.8									
Nominal ultimate tensile strength - tension	f_{uk}	[N/mm ²]	500	500	500	500	500	500	500
Nominal yield strength - tension	f_{yk}	[N/mm ²]	400	400	400	400	400	400	400
Cross sectional area - tension	A_s	[mm ²]	36.6	58	84.3	157	245	352.8	559.8
Elastic section modulus	W_{el}	[mm ³]	31.2	62.3	109.2	277.5	541	935	1868
Characteristic bending resistance	$M^0_{Rk,s}$	[Nm]	19	37	65	166	324	561	1124
Design bending resistance	M	[Nm]	15	30	52	133	259	449	899
Allowable bending resistance	M_{rec}	[Nm]	11	21	37	95	185	321	642
R-STUDS METRIC THREADED RODS - steel class 8.8									
Nominal ultimate tensile strength - tension	f_{uk}	[N/mm ²]	800	800	800	800	800	800	800
Nominal yield strength - tension	f_{yk}	[N/mm ²]	640	640	640	640	640	640	640
Cross sectional area - tension	A_s	[mm ²]	36.6	58	84.3	157	245	352.8	559.8
Elastic section modulus	W_{el}	[mm ³]	31.2	62.3	109.2	277.5	541	935	1868
Characteristic bending resistance	$M^0_{Rk,s}$	[Nm]	30	60	105	266	519	898	1799
Design bending resistance	M	[Nm]	24	48	84	213	416	718	1439
Allowable bending resistance	M_{rec}	[Nm]	17	34	60	152	297	513	1028
R-STUDS METRIC THREADED RODS - A4									
Nominal ultimate tensile strength - tension	f_{uk}	[N/mm ²]	700	700	700	700	700	700	700
Nominal yield strength - tension	f_{yk}	[N/mm ²]	350	350	350	350	350	350	350
Cross sectional area - tension	A_s	[mm ²]	36.6	58	84.3	157	245	352.8	559.8
Elastic section modulus	W_{el}	[mm ³]	31.2	62.3	109.2	277.5	541	935	1868
Characteristic bending resistance	$M^0_{Rk,s}$	[Nm]	26	52	92	233	454	786	1574
Design bending resistance	M	[Nm]	17	34	59	149	291	504	1009
Allowable bending resistance	M_{rec}	[Nm]	12	24	42	107	208	360	721

Basic performance data

R-STUDS

Performance data for single anchor without influence of edge distance and spacing

Size		M8	M10	M12	M16	M20	M24	M30	M8	M10	M12	M16	M20	M24	M30
Substrate		Non-cracked concrete						Cracked concrete							
CHARACTERISTIC LOAD															
TENSION LOAD N_{Rk}															
R-STUDS METRIC THREADED RODS - STEEL CLASS 5.8															
Minimum embedment depth	[kN]	18.0	23.5	23.5	23.5	36.1	47.5	66.4	15.1	16.7	16.7	16.7	25.8	33.9	47.3
Maximum embedment depth	[kN]	18.0	29.0	42.0	78.0	122.0	176.0	280.0	18.0	29.0	42.0	78.0	122.0	176.0	280.0
R-STUDS METRIC THREADED RODS - STEEL CLASS 8.8															
Minimum embedment depth	[kN]	23.5	23.5	23.5	23.5	36.1	47.5	66.4	15.1	16.7	16.7	16.7	25.8	33.9	47.3
Maximum embedment depth	[kN]	29.0	46.0	67.0	126.0	196.0	282.0	448.0	29.0	46.0	67.0	126.0	188.5	253.3	282.7
R-STUDS METRIC THREADED RODS - A4															
Minimum embedment depth	[kN]	23.5	23.5	23.5	23.5	36.1	47.5	66.4	15.1	16.7	16.7	16.7	25.8	33.9	47.3
Maximum embedment depth	[kN]	26.0	41.0	59.0	110.0	171.0	247.0	392.0	26.0	41.0	59.0	110.0	171.0	247.0	282.7
SHEAR LOAD V_{Rk}															
R-STUDS METRIC THREADED RODS - STEEL CLASS 5.8															
Minimum embedment depth	[kN]	9.0	14.0	21.0	39.0	61.0	88.0	132.8	9.0	14.0	21.0	33.5	51.5	67.7	94.7
Maximum embedment depth	[kN]	9.0	14.0	21.0	39.0	61.0	88.0	140.0	9.0	14.0	21.0	39.0	61.0	88.0	140.0
R-STUDS METRIC THREADED RODS - STEEL CLASS 8.8															
Minimum embedment depth	[kN]	15.0	23.0	34.0	46.9	72.3	95.0	132.8	15.0	23.0	33.5	33.5	51.5	67.7	94.7
Maximum embedment depth	[kN]	15.0	23.0	34.0	63.0	98.0	141.0	224.0	15.0	23.0	34.0	63.0	98.0	141.0	224.0
R-STUDS METRIC THREADED RODS - A4															
Minimum embedment depth	[kN]	13.0	20.5	29.0	46.9	72.3	95.0	132.8	13.0	20.0	29.0	33.5	51.5	67.7	94.7
Maximum embedment depth	[kN]	13.0	20.5	29.0	55.0	86.0	124.0	196.0	13.0	20.0	29.0	55.0	86.0	124.0	196.0

Basic performance data (cont.)

R-STUDS

Performance data for single anchor without influence of edge distance and spacing

Size		M8	M10	M12	M16	M20	M24	M30	M8	M10	M12	M16	M20	M24	M30
Substrate		Non-cracked concrete						Cracked concrete							
DESIGN LOAD															
TENSION LOAD N_{Rd}															
R-STUDS METRIC THREADED RODS - STEEL CLASS 5.8															
Minimum embedment depth	[kN]	12.0	15.7	15.7	15.7	24.1	31.7	44.3	10.1	11.2	11.2	11.2	17.2	22.6	31.6
Maximum embedment depth	[kN]	12.0	19.3	28.0	52.0	81.3	117.3	186.7	12.0	19.3	28.0	52.0	81.3	117.3	186.7
R-STUDS METRIC THREADED RODS - STEEL CLASS 8.8															
Minimum embedment depth	[kN]	15.7	15.7	15.7	15.7	24.1	31.7	44.3	10.1	11.2	11.2	11.2	17.2	22.6	31.6
Maximum embedment depth	[kN]	19.3	30.7	44.7	84.0	130.7	188.0	298.7	19.3	30.7	44.7	84.0	125.7	168.9	188.5
R-STUDS METRIC THREADED RODS - A4															
Minimum embedment depth	[kN]	13.9	15.7	15.7	15.7	24.1	31.7	44.3	10.1	11.2	11.2	11.2	17.2	22.6	31.6
Maximum embedment depth	[kN]	13.9	21.9	31.6	58.8	91.4	132.1	209.6	13.9	21.9	31.6	58.8	91.4	132.1	188.5
SHEAR LOAD V_{Rd}															
R-STUDS METRIC THREADED RODS - STEEL CLASS 5.8															
Minimum embedment depth	[kN]	7.2	11.2	16.8	31.2	48.2	63.3	88.5	7.2	11.2	16.8	22.3	34.4	45.2	63.1
Maximum embedment depth	[kN]	7.2	11.2	16.8	31.2	48.8	70.4	112.0	7.2	11.2	16.8	31.2	48.8	70.4	112.0
R-STUDS METRIC THREADED RODS - STEEL CLASS 8.8															
Minimum embedment depth	[kN]	12.0	18.4	27.2	31.3	48.2	63.3	88.5	12.0	18.4	22.3	22.3	34.4	45.2	63.1
Maximum embedment depth	[kN]	12.0	18.4	27.2	50.4	78.4	112.8	179.2	12.0	18.4	27.2	50.4	78.4	112.8	179.2
R-STUDS METRIC THREADED RODS - A4															
Minimum embedment depth	[kN]	8.3	13.1	18.6	31.3	48.2	63.3	88.5	8.3	12.8	18.6	22.3	34.4	45.2	63.1
Maximum embedment depth	[kN]	8.3	13.1	18.6	35.3	55.1	79.5	125.6	8.3	12.8	18.6	35.3	55.1	79.5	125.6
RECOMMENDED LOAD															
TENSION LOAD N_{rec}															
R-STUDS METRIC THREADED RODS - STEEL CLASS 5.8															
Minimum embedment depth	[kN]	8.57	11.2	11.2	11.2	17.2	22.6	31.6	7.18	7.97	7.97	7.97	12.3	16.1	22.5
Maximum embedment depth	[kN]	8.57	13.8	20.0	37.1	58.1	83.8	133.3	8.57	13.8	20.0	37.1	58.1	83.8	133.3
R-STUDS METRIC THREADED RODS - STEEL CLASS 8.8															
Minimum embedment depth	[kN]	11.2	11.2	11.2	11.2	17.2	22.6	31.6	7.18	7.97	7.97	7.97	12.3	16.1	22.5
Maximum embedment depth	[kN]	13.8	21.9	31.9	60.0	93.3	134.3	213.3	13.8	21.9	31.9	60.0	89.8	120.6	134.6
R-STUDS METRIC THREADED RODS - A4															
Minimum embedment depth	[kN]	9.93	11.2	11.2	11.2	17.2	22.6	31.6	7.18	7.97	7.97	7.97	12.3	16.1	22.5
Maximum embedment depth	[kN]	9.93	15.7	22.5	42.0	65.3	94.4	149.7	9.93	15.7	22.5	42.0	65.3	94.4	134.6
SHEAR LOAD V_{rec}															
R-STUDS METRIC THREADED RODS - STEEL CLASS 5.8															
Minimum embedment depth	[kN]	5.14	8.0	12.0	22.3	34.4	45.2	63.2	5.14	8.0	12.0	15.9	24.5	32.3	45.1
Maximum embedment depth	[kN]	5.14	8.0	12.0	22.3	34.9	50.3	80.0	5.14	8.0	12.0	22.3	34.9	50.3	80.0
R-STUDS METRIC THREADED RODS - STEEL CLASS 8.8															
Minimum embedment depth	[kN]	8.57	13.1	19.4	22.4	31.4	45.2	63.2	8.57	13.1	15.9	15.9	24.5	32.3	45.1
Maximum embedment depth	[kN]	8.57	13.1	19.4	36.0	56.0	80.6	128.0	8.57	13.1	19.4	36.0	56.0	80.6	128.0
R-STUDS METRIC THREADED RODS - A4															
Minimum embedment depth	[kN]	5.95	9.39	13.3	22.4	34.4	45.2	53.2	5.95	9.16	13.3	15.9	24.5	32.3	45.1
Maximum embedment depth	[kN]	5.95	9.39	13.3	25.2	39.4	56.8	89.7	5.95	9.16	13.3	25.2	39.4	56.8	89.7

Product commercial data

Product Code	Volume [m]	Quantity [pcs]			Weight [kg]			Bar Code
		Box	Outer	Pallet	Box	Outer	Pallet	
R-KER II-300	300	10	10	840	5.2	5.2	466.8	5906675293738
R-KER II-345	345	10	10	840	7.6	7.6	668.4	5906675395203
R-KER-II-400	400	10	10	560	8.2	8.2	489.2	5906675392103
R-KER-II-300-S	300	10	10	840	5.2	5.2	466.8	5906675432045
R-KER-II-400-S	400	10	10	560	8.2	8.2	489.2	5906675432076
R-KER II-300-W	300	10	10	840	5.2	5.2	466.8	5906675432038
R-KER II-345-W	345	10	10	840	7.6	7.6	668.4	5906675432052
R-KER-II-400-W	400	10	10	560	8.2	8.2	489.2	5906675432069

All products listed in this publication are branded and distributed with RAWLPLUG® or RAWL® trademarks.

R-KER II Hybrid resin with Sockets

High strength and versatile application in cracked and non-cracked concrete with internally threaded sockets (ITS)



Approvals and Reports

• ETA-17/0594



Product overview

Features and benefits

- Approved for use in cracked and non-cracked concrete
- Allows removal of bolt to leave a re-usable socket in place
- Winter version can be used in warmer temperatures for faster curing
- Suitable for use in dry and wet substrates as well as holes and substrates covered with water
- Rapid bonding time enables quick execution of works
- Very high load capacity
- Anchor does not generate tensions in the substrate which enables R-KER II to be specified where closer edge and spacing distances are required

Applications

- Temporary works/formworks support systems
- Balustrading
- Barriers
- Cladding restraints
- Masonry support
- Machinery
- Platforms
- Steelwork

Base materials

Approved for use in:

- Cracked concrete C20/25 - C50/60
- Non-cracked concrete C20/25-C50/60

Installation guide

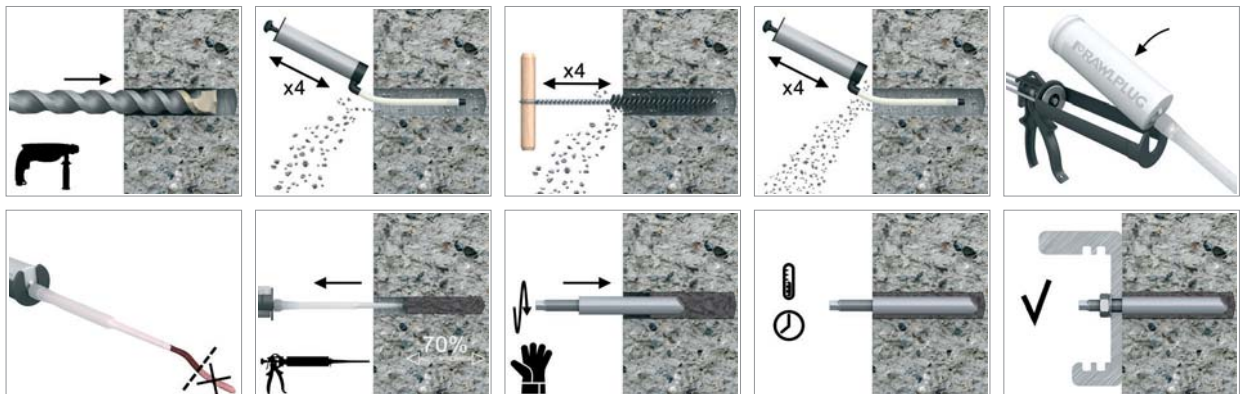

Installation guide (cont.)

1. Drill hole to the required diameter and depth for socket size being used.
2. Clean the drill hole thoroughly with brush and hand pump at least four times before installation.
3. Insert cartridge into gun and attach nozzle.
4. Dispense to waste until even colour is obtained (min. 10 cm)
5. Insert the mixer nozzle to the bottom of the drill hole and inject resin, slowly withdrawing the nozzle as the hole is filled to 70% of its depth.
6. Immediately insert the socket, slowly and with slight twisting motion. Remove any excess resin around the hole before it sets and leave it undisturbed until the curing time elapses.
7. Attach fixture and tighten the bolt to the required torque.

Product information

Product Code	Resin	Description / Resin Type	Volume
			[ml]
R-KER-II-300	R-KER-II	R-KER II Hybrid Resin	300
R-KER-II-345			345
R-KER-II-400			400
R-KER-II-300-S	R-KER-II-S	R-KER II Hybrid Resin for High Temperature (Summer) / Slow Cure Styrene Free Hybrid Resin	300
R-KER-II-400-S			400
R-KER-II-300-W	R-KER-II-W	R-KER II Hybrid Resin for Low Temperature (Winter) / Rapid Cure Styrene Free Hybrid Resin	300
R-KER-II-345-W			345
R-KER-II-400-W			400

SOCKETS

Size	Product Code		Anchor			Fixture	
	Steel class 5.8	Steel grade A4	Socket diameter	Length	Internal thread length	Hole diameter	Max. thickness t_{fix} for:
			d	L	l_0	d_f	$h_{nom, std}$
			[mm]	[mm]	[mm]	[mm]	[mm]
M6	R-ITS-Z-06075	R-ITS-A4-06075	10	75	24	7	-
M8	R-ITS-Z-08075	R-ITS-A4-08075	12	75	25	9	-
	R-ITS-Z-08090	R-ITS-A4-08090	12	90	25	9	-
M10	R-ITS-Z-10075	R-ITS-A4-10075	16	75	30	12	-
	R-ITS-Z-10100	R-ITS-A4-10100	16	100	30	12	-
M12	R-ITS-Z-12100	R-ITS-A4-12100	16	100	35	14	-
M16	R-ITS-Z-16125	R-ITS-A4-16125	24	125	50	18	-

Installation data

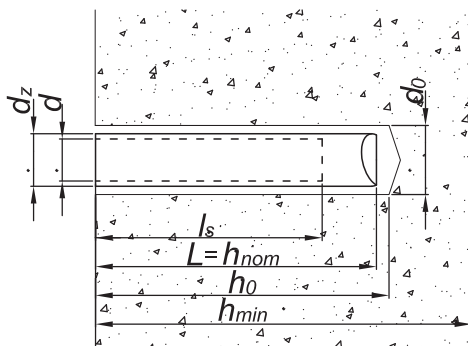

Installation data (cont.)

SOCKETS

Size			M6	M8		M10		M12	M16
Installation depth	h_{nom}	[mm]	75	75	90	75	100	100	125
Thread diameter	d	[mm]	6	8	8	10	10	12	16
Hole diameter in substrate	d_0	[mm]	12	14	14	20	20	20	28
Hole diameter in fixture	d_f	[mm]	7	9	9	12	12	14	18
Thread engagement length	h_s	[mm]	24	25	25	30	30	35	50
Min. hole depth in substrate	h_0	[mm]	$h_{nom} + 5$	$h_{nom} + 5$	$h_{nom} + 5$	$h_{nom} + 5$	$h_{nom} + 5$	$h_{nom} + 5$	$h_{nom} + 5$
Min. substrate thickness	h_{min}	[mm]	$h_{nom} + 30$ ≥ 100	$h_{nom} + 30$ ≥ 100	$h_{nom} + 30$ ≥ 100	$h_{nom} + 2d_0$	$h_{nom} + 2d_0$	$h_{nom} + 2d_0$	$h_{nom} + 2d_0$
Installation torque	T_{inst}	[Nm]	3	5	5	10	10	20	40
Min. spacing	s_{min}	[mm]	40	40	50	40	50	50	70
Min. edge distance	c_{min}	[mm]	40	40	50	40	50	50	70

Minimum working and curing time

Resin temperature °C	Concrete temperature °C	Working time [min]			Curing time* [min]		
		R-KER-II	R-KER-II S	R-KER-II W	R-KER-II	R-KER-II S	R-KER-II W
5	0	30	-	14	3h	-	2h
5	5	15	40	9	90	12h	60
10	10	8	20	5.5	60	8h	45
15	15	5	15	3	60	6h	30
20	20	2.5	10	2	45	4h	15
25	25	2	9.5	1.5	45	3h	10
25	30	2	7	1.5	45	2h	10
25	35	1.5	6.5	1	30	2h	5
25	40	1.5	6.5	1	30	1.5h	5

*For wet concrete the curing time must be doubled

Mechanical properties

Size			M6	M8	M10	M12	M16	
R-ITS-Z Internally Threaded Sockets								
Nominal ultimate tensile strength - tension	f_{uk}	[N/mm ²]	520	500	500	500	500	
Nominal yield strength - tension	f_{yk}	[N/mm ²]	420	400	400	400	400	
Cross sectional area - tension	A_s	[mm ²]	20.1	36.6	58	84.3	157	
Elastic section modulus	W_{el}	[mm ³]	21.21	50.3	98.2	169.7	402.1	
R-ITS-A4 Internally Threaded Sockets								
Nominal ultimate tensile strength - tension	f_{uk}	[N/mm ²]	700	700	700	700	700	
Nominal yield strength - tension	f_{yk}	[N/mm ²]	350	350	350	350	350	
Cross sectional area - tension	A_s	[mm ²]	20.1	36.6	58	84.3	157	
Elastic section modulus	W_{el}	[mm ³]	21.21	50.3	98.2	169.7	402.1	
Metric Threaded Rods - Steel Class 5.8								
Characteristic bending resistance	$M_{Rk,s}^0$	[Nm]	8	19	37	65	166	
Design bending resistance	M	[Nm]	6	15	30	52	133	
Allowable bending resistance	M_{rec}	[Nm]	5	11	21	37	95	
Metric Threaded Rods - Steel Class 8.8								
Characteristic bending resistance	$M_{Rk,s}^0$	[Nm]	12	30	60	105	266	
Design bending resistance	M	[Nm]	10	24	48	84	213	
Allowable bending resistance	M_{rec}	[Nm]	7	17	34	60	152	
Metric Threaded Rods - A4								
Characteristic bending resistance	$M_{Rk,s}^0$	[Nm]	11	26	52	92	233	
Design bending resistance	M	[Nm]	7	17	34	59	149	
Allowable bending resistance	M_{rec}	[Nm]	5	12	24	42	107	

Basic performance data

SOCKETS

Performance data for single anchor without influence of edge distance and spacing

Size		M6	M8	M10	M12	M16	M6	M8	M10	M12	M16				
Substrate		Non-cracked concrete					Cracked concrete								
Effective embedment depth h_{ef}	[mm]	75.0	90.0	75.0	100.0	125.0	75.0	90.0	75.0	100.0	125.0				
CHARACTERISTIC LOAD															
TENSION LOAD N_{rk}															
METRIC THREADED RODS - STEEL CLASS 5.8	[kN]	10.00	18.0	18.0	29.0	29.0	42.0	70.6	10.00	18.0	18.0	23.4	29.0	36.0	37.7
METRIC THREADED RODS - STEEL CLASS 8.8	[kN]	16.0	29.0	29.0	32.8	46.0	50.5	70.6	16.0	23.4	29.0	23.4	36.0	36.0	37.7
METRIC THREADED RODS - A4	[kN]	14.0	25.0	25.0	32.8	40.0	50.5	70.6	14.0	23.4	25.0	23.4	36.0	36.0	37.7
SHEAR LOAD V_{rk}															
METRIC THREADED RODS - STEEL CLASS 5.8	[kN]	5.00	9.00	9.00	14.5	14.5	21.0	39.0	5.00	9.00	9.00	14.5	14.5	21.0	39.0
METRIC THREADED RODS - STEEL CLASS 8.8	[kN]	8.00	14.5	14.5	23.0	23.0	33.5	62.5	8.00	14.5	14.5	23.0	23.0	33.5	62.5
METRIC THREADED RODS - A4	[kN]	7.00	12.5	12.5	20.0	20.0	29.5	54.5	7.00	12.5	12.5	20.0	20.0	29.5	54.5
DESIGN LOAD															
TENSION LOAD N_{rd}															
METRIC THREADED RODS - STEEL CLASS 5.8	[kN]	6.67	12.0	12.0	19.3	19.3	28.0	47.1	6.67	12.0	12.0	15.6	19.3	24.0	25.1
METRIC THREADED RODS - STEEL CLASS 8.8	[kN]	10.7	19.3	19.3	21.9	30.7	33.7	47.1	10.7	15.6	19.3	15.6	24.0	24.0	25.1
METRIC THREADED RODS - A4	[kN]	7.49	13.4	13.4	21.4	21.4	32.6	47.1	7.49	13.4	13.4	15.6	21.4	24.0	25.1
SHEAR LOAD V_{rd}															
METRIC THREADED RODS - STEEL CLASS 5.8	[kN]	4.00	7.20	7.20	11.6	11.6	16.8	31.2	4.00	7.20	7.20	11.6	11.6	16.8	31.2
METRIC THREADED RODS - STEEL CLASS 8.8	[kN]	6.40	11.6	11.6	18.4	18.4	26.8	50.0	6.40	11.6	11.6	18.4	18.4	26.8	50.0
METRIC THREADED RODS - A4	[kN]	4.49	8.01	8.01	12.8	12.8	18.9	34.9	4.49	8.01	8.01	12.8	12.8	18.9	34.9
RECOMMENDED LOAD															
TENSION LOAD N_{rec}															
METRIC THREADED RODS - STEEL CLASS 5.8	[kN]	4.76	8.57	8.57	13.8	13.8	20.0	33.6	4.76	8.57	8.57	11.1	13.8	17.1	18.0
METRIC THREADED RODS - STEEL CLASS 8.8	[kN]	7.62	13.8	13.8	15.6	21.9	24.1	33.6	7.62	11.1	13.8	11.1	17.1	17.1	20.0
METRIC THREADED RODS - A4	[kN]	5.35	9.55	9.55	15.3	15.3	22.5	33.6	5.35	9.55	9.55	11.1	15.3	17.1	18.0
SHEAR LOAD V_{rec}															
METRIC THREADED RODS - STEEL CLASS 5.8	[kN]	2.86	5.14	5.14	8.29	8.29	12.0	22.3	2.86	5.14	5.14	8.29	8.29	12.0	22.3
METRIC THREADED RODS - STEEL CLASS 8.8	[kN]	4.57	8.29	8.29	13.1	13.1	19.1	35.7	4.57	8.29	8.29	13.1	13.1	19.1	35.7
METRIC THREADED RODS - A4	[kN]	3.21	5.72	5.72	9.16	9.16	13.5	25.0	3.21	5.72	5.72	9.16	9.16	13.5	25.0

Product commercial data

Product Code	Volume [ml]	Quantity [pcs]			Weight [kg]			Bar Codes
		Box	Outer	Pallet	Box	Outer	Pallet	
R-KER-II-300	300	10	10	840	5.2	5.2	466.8	5906675293738
R-KER-II-345	345	10	10	840	7.6	7.6	668.4	5906675395203
R-KER-II-400	400	10	10	560	8.2	8.2	489.2	5906675392103
R-KER-II-300-S	300	10	10	840	5.2	5.2	466.8	5906675432045
R-KER-II-400-S	400	10	10	560	8.2	8.2	489.2	5906675432076
R-KER-II-300-W	300	10	10	840	5.2	5.2	466.8	5906675432038
R-KER-II-345-W	345	10	10	840	7.6	7.6	668.4	5906675432052
R-KER-II-400-W	400	10	10	560	8.2	8.2	489.2	5906675432069

R-KER-II Hybrid with Rebars as an Anchor

High performance hybrid resin approved for use with reinforcement bars as anchors



Installation movie



Approvals and Reports

- ETA-17/0594

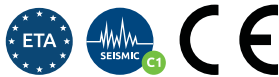

Product overview

Features and benefits

- Approved for use with rebar as an anchor for use in cracked and non-cracked concrete
- Winter version can be used for faster curing
- Suitable for use in dry and wet substrates as well as holes and substrates covered with water
- Rapid bonding time enables quick execution of works
- Very high load capacity
- Anchor does not generate tensions in the substrate which enables its installation in minimum distance and close to the edge of the substrate
- Suitable for multiple use. Partly used product can be reused after fitting new nozzle
- Seismic category C1
- Three methods for preparing core holes, including automatic Dustless Drill

Applications

- Curtain walling
- Balustrading
- Barriers
- Cable trays
- Cladding restraints
- Structural steelwork
- Rebar dowelling
- Starter bars
- Rebar missed-outs

Base materials

Approved for use in:

- Non-cracked concrete C20/25-C50/60
- Cracked concrete C20/25-C50/60

Installation guide

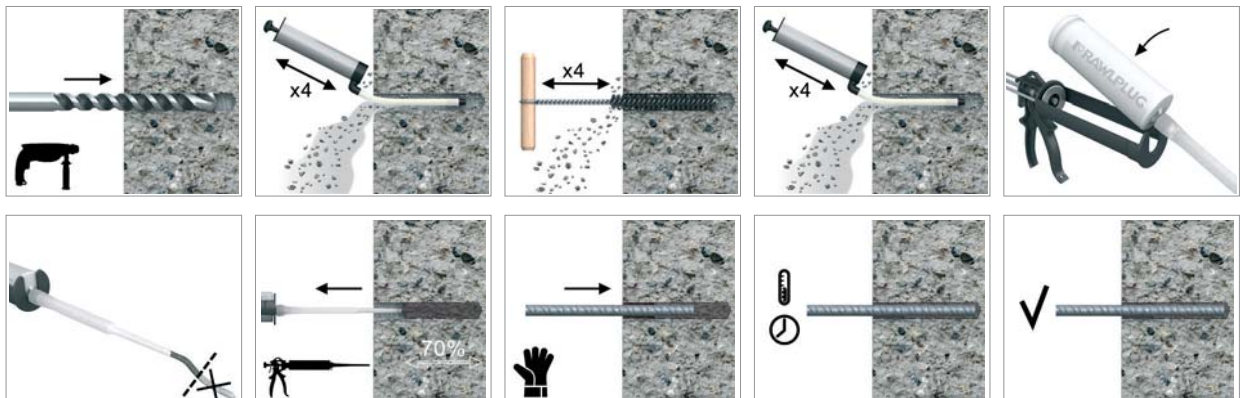

Installation guide (cont.)

1. Drill hole to the required diameter and depth for rebar size being used.
2. Clean the drill hole thoroughly with brush and hand pump at least four times before installation.
3. Insert cartridge into gun and attach nozzle.
4. Dispense to waste until even colour is obtained (min. 10 cm)
5. Insert the mixer nozzle to the bottom of the drill hole and inject resin, slowly withdrawing the nozzle as the hole is filled to 70% of its depth.
6. Immediately insert the rebar, slowly and with slight twisting motion. Remove any excess resin around the hole before it sets and leave it undisturbed until the curing time elapses. Attach fixture and tighten the nut to the required torque.

Product information

Product Code	Resin	Description / Resin Type	Volume
			[ml]
R-KER-II-300	R-KER-II	R-KER II Hybrid Resin	300
R-KER-II-345			345
R-KER-II-400			400
R-KER-II-300-S	R-KER-II-S	R-KER II Hybrid Resin for High Temperature (Summer) / Slow Cure Styrene Free Hybrid Resin	300
R-KER-II-400-S			400
R-KER-II-300-W	R-KER-II-W	R-KER II Hybrid Resin for Low Temperature (Winter) / Rapid Cure Styrene Free Hybrid Resin	300
R-KER-II-345-W			345
R-KER-II-400-W			400

Installation data

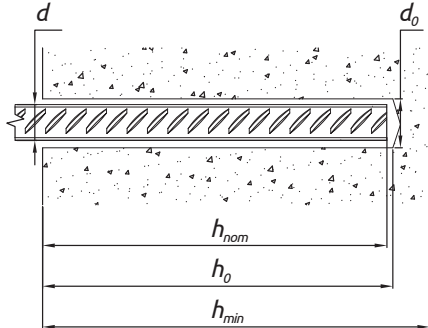

REBARS AS ANCHORS

Size			Ø8	Ø10	Ø12	Ø14	Ø16	Ø20	Ø25	Ø32
Rebar diameter	d	[mm]	8	10	12	14	16	20	25	32
Hole diameter in substrate	d_0	[mm]	12	14	18	18	22	26	32	40
Min. hole depth in substrate	h_0	[mm]	$h_{nom} + 5$	$h_{nom} + 5$	$h_{nom} + 5$	$h_{nom} + 5$	$h_{nom} + 5$	$h_{nom} + 5$	$h_{nom} + 5$	$h_{nom} + 5$
Min. substrate thickness	h_{min}	[mm]	$h_{nom} + 30$ ≥ 100	$h_{nom} + 30$ ≥ 100	$h_{nom} + 30$ ≥ 100	$h_{nom} + 30$ ≥ 100	$h_{nom} + 2d_0$	$h_{nom} + 2d_0$	$h_{nom} + 2d_0$	$h_{nom} + 2d_0$
Min. spacing	s_{min}	[mm]	40	40	40	40	40	40	50	70
Min. edge distance	c_{min}	[mm]	40	40	40	40	40	40	50	70
MINIMUM EMBEDMENT DEPTH										
Installation depth	$h_{nom, min}$	[mm]	60	60	60	60	64	80	100	128
MAXIMUM EMBEDMENT DEPTH										
Installation depth	$h_{nom, max}$	[mm]	160	200	240	240	320	400	500	640

Installation data (cont.)

Minimum working and curing time

Resin temperature °C	Concrete temperature °C	Working time [min]			Curing time* [min.]		
		R-KER-II	R-KER-II S	R-KER-II W	R-KER-II	R-KER-II S	R-KER-II W
5	0	30	-	14	3 h	-	2h
5	5	15	40	9	90	12h	60
10	10	8	20	5.5	60	8h	45
15	15	5	15	3	60	6h	30
20	20	2.5	10	2	45	4h	15
25	25	2	9.5	1.5	45	3h	10
25	30	2	7	1.5	45	2h	10
25	35	1.5	6.5	1	30	2h	5
25	40	1.5	6.5	1	30	1,5h	5

*For wet concrete the curing time must be doubled

Mechanical properties

REBARS AS ANCHORS

Size			Ø8	Ø10	Ø12	Ø14	Ø16	Ø20	Ø25	Ø32
f_{uk} = 540 (e.g. 500 B acc. to BS 4449; B 500 B acc. to SS 560)										
Nominal ultimate tensile strength - tension	f _{uk}	[N/mm ²]	540	540	540	540	540	540	540	540
Nominal yield strength - tension	f _{yk}	[N/mm ²]	500	500	500	500	500	500	500	500
Cross sectional area - tension	A _s	[mm ²]	50.3	78.5	113.1	153.9	201.1	314.2	490.9	804.2
Elastic section modulus	W _{el}	[mm ³]	50.3	98.2	169.6	269.4	402.1	785.4	1534	3217
f_{uk} = 575 (e.g. B 500 SP acc. to EC2)										
Nominal ultimate tensile strength - tension	f _{uk}	[N/mm ²]	575	575	575	575	575	575	575	575
Nominal yield strength - tension	f _{yk}	[N/mm ²]	500	500	500	500	500	500	500	500
Cross sectional area - tension	A _s	[mm ²]	50.3	78.5	113.1	153.9	201.1	314.2	490.9	804.2
Elastic section modulus	W _{el}	[mm ³]	50.3	98.2	169.6	269.4	402.1	785.4	1534	3217
f_{uk} = 620 (e.g. G-60 acc. to ASTM 615)										
Nominal ultimate tensile strength - tension	f _{uk}	[N/mm ²]	620	620	620	620	620	620	620	620
Nominal yield strength - tension	f _{yk}	[N/mm ²]	420	420	420	420	420	420	420	420
Cross sectional area - tension	A _s	[mm ²]	50.3	78.5	113.1	153.9	201.1	314.2	490.9	804.2
Elastic section modulus	W _{el}	[mm ³]	50.3	98.2	169.6	269.4	402.1	785.4	1534	3217

Basic performance data

REBARS AS ANCHORS

Size		Ø8	Ø10	Ø12	Ø14	Ø16	Ø20	Ø25	Ø32	Ø8	Ø10	Ø12	Ø14	Ø16	Ø20	Ø25	Ø32
Substrate		Non-cracked concrete								Cracked concrete							
CHARACTERISTIC LOAD																	
TENSION LOAD N_{Rk}																	
fuk = 540 (e.g. 500 B acc. to BS 4449; B 500 B acc. to SS 560)																	
Minimum embedment depth	[kN]	19.6	23.5	23.5	23.5	25.9	36.1	50.5	73.1	12.1	16.7	16.7	16.7	18.4	25.8	36.0	45.0
Maximum embedment depth	[kN]	27.1	42.4	61.1	83.1	108.6	169.7	265.1	434.3	27.1	42.4	61.1	83.1	108.6	169.7	235.6	225.2
fuk = 575 (e.g. B 500 SP acc. to EC2)																	
Minimum embedment depth	[kN]	19.6	23.5	23.5	23.5	25.9	36.1	50.5	73.1	12.1	16.7	16.7	16.7	18.4	25.8	36.0	45.0
Maximum embedment depth	[kN]	28.9	45.2	65.0	88.5	115.6	180.6	282.3	462.4	28.9	45.2	65.0	88.5	115.6	180.6	235.6	225.2
fuk = 620 (e.g. G-60 acc. to ASTM 615)																	
Minimum embedment depth	[kN]	19.6	23.5	23.5	23.5	25.9	36.1	50.5	73.1	12.1	16.7	16.7	16.7	18.4	25.8	36.0	45.0
Maximum embedment depth	[kN]	31.2	48.7	70.1	95.4	124.7	194.8	304.3	482.6	31.2	48.7	70.1	95.4	124.7	188.5	235.6	225.2
SHEAR LOAD V_{Rk}																	
fuk = 540 (e.g. 500 B acc. to BS 4449; B 500 B acc. to SS 560)																	
Minimum embedment depth	[kN]	13.6	21.2	30.5	41.6	51.7	72.3	101.0	146.3	13.6	21.2	30.5	33.5	36.9	51.5	72.0	90.1
Maximum embedment depth	[kN]	13.6	21.2	30.5	41.6	54.3	84.8	132.5	217.2	13.6	21.2	30.5	41.6	54.3	84.8	132.5	217.2
fuk = 575 (e.g. B 500 SP acc. to EC2)																	
Minimum embedment depth	[kN]	14.5	22.6	32.5	44.3	51.7	72.3	101.0	146.3	14.5	22.6	32.5	33.5	36.9	51.5	72.0	90.1
Maximum embedment depth	[kN]	14.5	22.6	32.5	44.3	57.8	90.3	141.1	231.2	14.5	22.6	32.5	44.3	57.8	90.3	141.1	231.2
fuk = 620 (e.g. G-60 acc. to ASTM 615)																	
Minimum embedment depth	[kN]	15.6	24.4	35.1	46.9	51.7	72.3	101.0	146.3	15.6	24.4	33.5	33.5	36.9	51.5	72.0	90.1
Maximum embedment depth	[kN]	15.6	24.4	35.1	47.7	62.3	97.4	152.2	249.3	15.6	24.4	35.1	47.7	62.3	97.4	152.2	249.3
DESIGN LOAD																	
TENSION LOAD N_{Rd}																	
fuk = 540 (e.g. 500 B acc. to BS 4449; B 500 B acc. to SS 560)																	
Minimum embedment depth	[kN]	13.1	15.7	15.7	15.7	17.2	24.1	33.7	48.8	8.04	11.2	11.2	11.2	12.3	17.2	24.0	30.3
Maximum embedment depth	[kN]	19.4	30.3	43.6	59.4	77.6	121.2	189.3	310.2	19.4	30.3	43.6	59.4	77.6	121.2	157.1	150.1
fuk = 575 (e.g. B 500 SP acc. to EC2)																	
Minimum embedment depth	[kN]	13.1	15.7	15.7	15.7	17.2	24.1	33.7	48.8	8.04	11.2	11.2	11.2	12.3	17.2	24.0	30.3
Maximum embedment depth	[kN]	20.6	32.3	46.5	63.2	82.6	129.0	201.6	321.7	20.6	32.3	46.5	63.2	82.6	125.7	157.1	150.1
fuk = 620 (e.g. G-60 acc. to ASTM 615)																	
Minimum embedment depth	[kN]	13.1	15.7	15.7	15.7	17.2	24.1	33.7	48.8	8.04	11.2	11.2	11.2	12.3	17.2	24.0	30.3
Maximum embedment depth	[kN]	22.3	34.8	50.1	68.2	89.0	139.1	217.4	321.7	21.5	34.8	50.1	68.2	89.0	125.7	157.1	150.1
SHEAR LOAD V_{Rd}																	
fuk = 540 (e.g. 500 B acc. to BS 4449; B 500 B acc. to SS 560)																	
Minimum embedment depth	[kN]	9.05	14.1	20.4	27.7	34.5	48.2	67.3	97.5	9.05	14.1	20.4	22.3	24.6	34.4	48.0	60.1
Maximum embedment depth	[kN]	9.05	14.1	20.4	27.7	36.2	56.6	88.4	144.8	9.05	14.1	20.4	27.7	36.2	56.6	88.4	144.8
fuk = 575 (e.g. B 500 SP acc. to EC2)																	
Minimum embedment depth	[kN]	9.63	15.1	21.7	29.5	34.5	48.2	67.3	97.5	9.63	15.1	21.7	22.3	24.6	34.4	48.0	60.1
Maximum embedment depth	[kN]	9.63	15.1	21.7	29.5	38.5	60.2	94.1	154.2	9.63	15.1	21.7	29.5	38.5	60.2	94.1	154.2
fuk = 620 (e.g. G-60 acc. to ASTM 615)																	
Minimum embedment depth	[kN]	10.4	16.2	23.4	31.3	34.5	48.2	67.3	97.5	10.4	16.2	22.3	22.3	24.6	34.4	48.0	60.1
Maximum embedment depth	[kN]	10.4	16.2	23.4	31.8	41.6	64.9	101.5	166.2	10.4	16.2	23.4	31.8	41.6	64.9	101.5	166.2

Basic performance data (cont.)

REBARS AS ANCHORS

Size		Ø8	Ø10	Ø12	Ø14	Ø16	Ø20	Ø25	Ø32	Ø8	Ø10	Ø12	Ø14	Ø16	Ø20	Ø25	Ø32
RECOMMENDED LOAD																	
TENSION LOAD N_{rec}																	
fuk = 540 (e.g. 500 B acc. to BS 4449; B 500 B acc. to SS 560)																	
Minimum embedment depth	[kN]	9.34	11.2	11.2	11.2	12.3	17.2	24.1	34.8	5.74	7.97	7.97	7.97	8.78	12.3	17.1	21.5
Maximum embedment depth	[kN]	13.9	21.6	31.2	42.4	55.4	86.6	135.2	221.6	13.9	21.6	31.2	42.4	55.4	86.6	112.2	107.2
fuk = 575 (e.g. B 500 SP acc. to EC2)																	
Minimum embedment depth	[kN]	9.34	11.2	11.2	11.2	12.3	17.2	24.1	34.8	5.74	7.97	7.97	7.97	8.78	12.3	17.1	21.5
Maximum embedment depth	[kN]	14.8	23.0	33.2	45.2	59.0	92.2	144.0	229.8	14.8	23.0	33.2	45.2	59.0	89.8	111.2	107.2
fuk = 620 (e.g. G-60 acc. to ASTM 615)																	
Minimum embedment depth	[kN]	9.34	11.2	11.2	11.2	12.3	17.2	24.1	34.8	5.74	7.97	7.97	7.97	8.78	12.3	17.1	21.5
Maximum embedment depth	[kN]	15.9	24.8	35.8	48.7	63.6	99.4	155.3	229.8	15.3	24.8	35.8	48.7	63.6	89.8	112.2	107.2
SHEAR LOAD V_{rec}																	
fuk = 540 (e.g. 500 B acc. to BS 4449; B 500 B acc. to SS 560)																	
Minimum embedment depth	[kN]	6.46	10.1	14.5	19.8	24.6	34.4	48.1	69.7	6.46	10.1	14.5	15.9	17.6	24.5	34.3	42.9
Maximum embedment depth	[kN]	6.46	10.1	14.5	19.8	25.9	40.4	63.1	103.4	6.46	10.1	14.5	19.8	25.9	40.4	63.1	103.4
fuk = 575 (e.g. B 500 SP acc. to EC2)																	
Minimum embedment depth	[kN]	6.88	10.8	15.5	21.1	24.6	34.4	48.1	69.7	6.88	10.8	15.5	15.9	17.6	24.5	34.3	42.9
Maximum embedment depth	[kN]	6.88	10.8	15.5	21.1	27.5	43.0	67.2	110.1	6.88	10.8	15.5	21.1	27.5	43.0	67.2	110.1
fuk = 620 (e.g. G-60 acc. to ASTM 615)																	
Minimum embedment depth	[kN]	7.42	11.6	16.7	22.4	24.6	34.4	48.1	69.7	7.42	11.6	15.9	15.9	17.6	24.5	34.3	42.9
Maximum embedment depth	[kN]	7.42	11.6	16.7	22.7	29.7	46.4	72.5	118.7	7.42	11.6	16.7	22.7	29.7	46.4	72.5	118.7

Product commercial data

Product Code	Volume [m ³]	Quantity [pcs]			Weight [kg]			Bar Code
		Box	Outer	Pallet	Box	Outer	Pallet	
R-KER II-300	300	10	10	840	5.2	5.2	466.8	5906675293738
R-KER II-345	345	10	10	840	7.6	7.6	668.4	5906675395203
R-KER II-400	400	10	10	560	8.2	8.2	489.2	5906675392103
R-KER II-300-S	300	10	10	840	5.2	5.2	466.8	5906675432045
R-KER II-400-S	400	10	10	560	8.2	8.2	489.2	5906675432076
R-KER II-300-W	300	10	10	840	5.2	5.2	466.8	5906675432038
R-KER II-345-W	345	10	10	840	7.6	7.6	668.4	5906675432052
R-KER II-400-W	400	10	10	560	8.2	8.2	489.2	5906675432069

R-KER-II Hybrid with Post-Installed Rebars

High performance hybrid resin approved for use with post-installed rebar connections



Installation movie



Approvals and Reports

- ETA-17/0874



Product overview

Features and benefits

- Approved for use with post-installed rebars
- Suitable for use in dry and wet substrates
- Very high load capacity
- Anchor does not generate tensions in the substrate which enables R-KER II to be specified where closer edge and spacing distances are required
- Suitable for multiple use. Partly used product can be reused after fitting new nozzle
- Three methods for preparing core holes, including automatic Dustless Drill
- High depth of anchoring up to 1,5 m for rebar applications

Applications

- Post-installed rebar connections
- Rebar
- Temporary works/formworks support systems
- Safety barriers
- Barriers
- Platforms
- Rebar dowelling
- Starter bars
- Rebar missed-outs

Base materials

Approved for use in:

- Concrete C12/15-C50/60

Installation guide

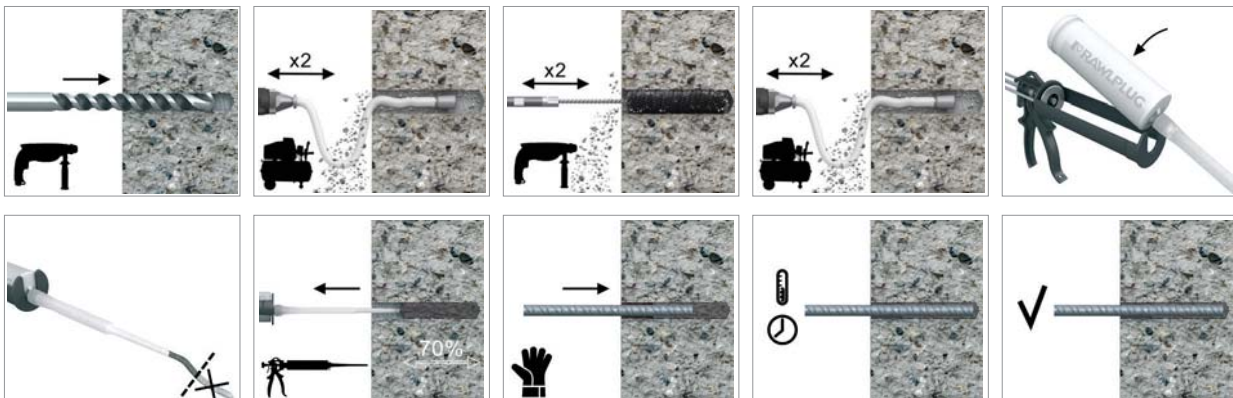

Installation guide (cont.)

1. Drill hole to the required diameter and depth for rebar size being used.
2. Clean the drill hole thoroughly with brush and pump (compressed air) at least two times before installation
3. Insert cartridge into gun and attach nozzle.
4. Dispense to waste until even colour is obtained (min. 10 cm)
5. Insert the mixer nozzle to the bottom of the drill hole and inject resin, slowly withdrawing the nozzle as the hole is filled to 70% of its depth.
6. Immediately insert the rebar, slowly and with slight twisting motion. Remove any excess resin around the hole before it sets and leave it undisturbed until the curing time elapses. Attach fixture and tighten the nut to the required torque.

Product information

Product Code	Resin	Description / Resin Type	Volume
			[m]
R-KER-II-300-S	R-KER-II-S	R-KER II Hybrid Resin for High Temperature (Summer) / Slow Cure Styrene Free Hybrid Resin	300
R-KER-II-400-S			400

Installation data

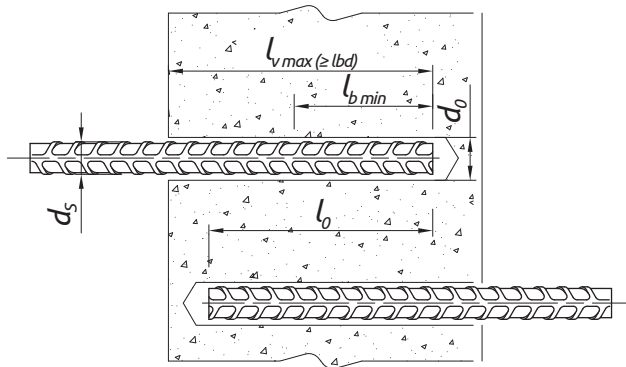

POST INSTALLED REBARS

Size			Ø8	Ø10	Ø12	Ø14	Ø16	Ø20	Ø25	Ø28	Ø32	Ø40
Rebar diameter	d_s	[mm]	8	10	12	14	16	20	25	28	32	40
Hole diameter in substrate	d_0	[mm]	12	14	16	18	20	25	30	35	40	50
Brush diameter	-	[mm]	14	16	18	20	22	27	32	37	42	50
Min. anchorage length	$l_{b, min.}$	[mm]	115	145	170	200	230	285	355	400	455	570
Min. lap length (overlap splice)	$l_{0, min.}$	[mm]	200	215	255	300	340	430	540	600	690	860
Max. anchorage length	$l_{v, max.}$	[mm]	400	500	600	700	800	1000	1200	1400	1500	1000

Minimum working and curing time

Resin temperature	Concrete temperature	Working time [min]	Curing time* [min.]
°C	°C	R-KER-II S	R-KER-II S
5	5	40	12h
10	10	20	8h
15	15	15	6h
20	20	10	4h
25	25	9.5	3h
25	30	7	2h
25	35	6.5	2h
25	40	6.5	1.5h
25	45	6	1h
25	50	6	0.5h

*For wet concrete the curing time must be doubled

Mechanical properties

POST INSTALLED REBARS

Size			Ø8	Ø10	Ø12	Ø14	Ø16	Ø20	Ø25	Ø28	Ø32	Ø40
fyk = 410 (e.g. 34GS acc. to EC2)												
Nominal yield strength - tension	f_{yk}	[N/mm ²]	410	410	410	410	410	410	410	410	410	410
Cross sectional area - tension	A_s	[mm ²]	50.3	78.5	113.1	153.9	201.1	314.2	490.9	615.8	804.2	1256.6
fyk = 420 (e.g. G-60 acc. to ASTM 615)												
Nominal yield strength - tension	f_{yk}	[N/mm ²]	420	420	420	420	420	420	420	420	420	420
Cross sectional area - tension	A_s	[mm ²]	50.3	78.5	113.1	153.9	201.1	314.2	490.9	615.8	804.2	1256.6
fyk = 460 (e.g. 460 B acc. to BS 4449)												
Nominal yield strength - tension	f_{yk}	[N/mm ²]	460	460	460	460	460	460	460	460	460	460
Cross sectional area - tension	A_s	[mm ²]	50.3	78.5	113.1	153.9	201.1	314.2	490.9	615.8	804.2	1256.6
fyk = 500 (e.g. B 500 SP acc. to EC2; 500 B acc. to BS 4449; B 500 B acc. to SS 560)												
Nominal yield strength - tension	f_{yk}	[N/mm ²]	500	500	500	500	500	500	500	500	500	500
Cross sectional area - tension	A_s	[mm ²]	50.3	78.5	113.1	153.9	201.1	314.2	490.9	615.8	804.2	1256.6
fyk = 600 (e.g. B 600 B acc. to SS 560)												
Nominal yield strength - tension	f_{yk}	[N/mm ²]	600	600	600	600	600	600	600	600	600	600
Cross sectional area - tension	A_s	[mm ²]	50.3	78.5	113.1	153.9	201.1	314.2	490.9	615.8	804.2	1256.6

Basic performance data

ANCHORAGES – DESIGN RESISTANCE – CONCRETE C20/25, NOMINAL YIELD STRENGTH FOR TENSION - $f_{yk} = 410$ [N/mm ²]																									
$\frac{l_{bd}}{d_s}$ [mm]	100	120	140	160	180	200	250	300	350	400	450	500	550	600	650	700	750	800	850	900	950	1000	1250	1500	Steel failure
8	5,8	6,9	8,1	9,2	10,4	11,6	14,5	17,3	17,9	17,9	-	-	-	-	-	-	-	-	-	-	-	-	-	-	17,9
10	-	8,7	10,1	11,6	13,0	14,5	18,1	21,7	25,3	28,0	28,0	28,0	-	-	-	-	-	-	-	-	-	-	-	-	28,0
12	-	-	12,1	13,9	15,6	17,3	21,7	26,0	30,3	34,7	39,0	40,3	40,3	40,3	-	-	-	-	-	-	-	-	-	-	40,3
14	-	-	-	-	18,2	20,2	25,3	30,3	35,4	40,5	45,5	50,6	54,9	54,9	54,9	54,9	-	-	-	-	-	-	-	-	54,9
16	-	-	-	-	-	23,1	28,9	34,7	40,5	46,2	52,0	57,8	63,6	69,4	71,7	71,7	71,7	71,7	-	-	-	-	-	-	71,7
20	-	-	-	-	-	-	36,1	43,4	50,6	57,8	65,0	72,3	79,5	86,7	93,9	101,2	108,4	112,0	112,0	112,0	112,0	112,0	-	-	112,0
25	-	-	-	-	-	-	-	54,2	63,2	72,3	81,3	90,3	99,4	108,4	117,4	126,4	135,5	144,5	153,5	162,6	171,6	175,0	-	-	175,0
28	-	-	-	-	-	-	-	-	70,8	80,9	91,0	101,2	111,3	121,4	131,5	141,6	151,7	161,9	172,0	182,1	192,2	202,3	219,5	-	219,5
32	-	-	-	-	-	-	-	-	-	92,5	104,0	115,6	127,2	138,7	150,3	161,9	173,4	185,0	196,5	208,1	219,7	231,2	286,7	286,7	286,7
40	-	-	-	-	-	-	-	-	-	-	-	125,7	138,2	150,8	163,4	175,9	188,5	201,1	213,6	226,2	238,8	251,3	-	-	448,0

ANCHORAGES – DESIGN RESISTANCE – CONCRETE C50/60, NOMINAL YIELD STRENGTH FOR TENSION - $f_{yk} = 410$ [N/mm ²]																									
$\frac{l_{bd}}{d_s}$ [mm]	100	120	140	160	180	200	250	300	350	400	450	500	550	600	650	700	750	800	850	900	950	1000	1250	1500	Steel failure
8	10,8	13,0	15,1	17,3	17,9	17,9	17,9	17,9	17,9	17,9	-	-	-	-	-	-	-	-	-	-	-	-	-	-	17,9
10	13,5	16,2	18,9	21,6	24,3	27,0	28,0	28,0	28,0	28,0	28,0	28,0	-	-	-	-	-	-	-	-	-	-	-	-	28,0
12	-	18,1	21,1	24,1	27,1	30,2	37,7	40,3	40,3	40,3	40,3	40,3	40,3	40,3	-	-	-	-	-	-	-	-	-	-	40,3
14	-	-	24,6	28,1	31,7	35,2	44,0	52,8	54,9	54,9	54,9	54,9	54,9	54,9	54,9	54,9	-	-	-	-	-	-	-	-	54,9
16	-	-	-	29,8	33,5	37,2	46,5	55,8	65,1	71,7	71,7	71,7	71,7	71,7	71,7	71,7	71,7	71,7	-	-	-	-	-	-	71,7
20	-	-	-	-	-	46,5	58,1	69,7	81,4	93,0	104,6	112,0	112,0	112,0	112,0	112,0	112,0	112,0	112,0	112,0	112,0	112,0	-	-	112,0
25	-	-	-	-	-	-	66,8	80,1	93,5	106,8	120,2	133,5	146,9	160,2	173,6	175,0	175,0	175,0	175,0	175,0	175,0	175,0	-	-	175,0
28	-	-	-	-	-	-	-	89,7	104,7	119,6	134,6	149,5	164,5	179,4	194,4	209,4	219,5	219,5	219,5	219,5	219,5	219,5	219,5	-	219,5
32	-	-	-	-	-	-	-	-	105,6	120,6	135,7	150,8	165,9	181,0	196,0	211,1	226,2	241,3	256,4	271,4	286,5	286,7	286,7	286,7	286,7
40	-	-	-	-	-	-	-	-	-	-	130,1	144,5	159,0	173,4	187,9	202,3	216,8	231,2	245,7	260,1	274,6	289,0	-	-	448,0

Basic performance data (cont.)

OVERLAP SPLICE – DESIGN RESISTANCE – CONCRETE C20/25, NOMINAL YIELD STRENGTH FOR TENSION - $f_{yk} = 410$ [N/mm ²]																									
$\frac{l_b}{d_s}$	200	220	240	260	280	300	325	350	375	400	450	500	550	600	650	700	750	800	850	900	950	1000	1250	1500	Steel Failure
8	11,6	12,7	13,9	15,0	16,2	17,3	17,9	17,9	17,9	17,9	-	-	-	-	-	-	-	-	-	-	-	-	-	-	17,9
10	14,5	15,9	17,3	18,8	20,2	21,7	23,5	25,3	27,1	28,0	28,0	28,0	-	-	-	-	-	-	-	-	-	-	-	-	28,0
12	-	19,1	20,8	22,5	24,3	26,0	28,2	30,3	32,5	34,7	39,0	40,3	40,3	40,3	-	-	-	-	-	-	-	-	-	-	40,3
14	-	-	-	26,3	28,3	30,3	32,9	35,4	37,9	40,5	45,5	50,6	54,9	54,9	54,9	54,9	-	-	-	-	-	-	-	-	54,9
16	-	-	-	-	32,4	34,7	37,6	40,5	43,4	46,2	52,0	57,8	63,6	69,4	71,7	71,7	71,7	71,7	-	-	-	-	-	-	71,7
20	-	-	-	-	-	-	-	50,6	54,2	57,8	65,0	72,3	79,5	86,7	93,9	101,2	108,4	112,0	112,0	112,0	112,0	112,0	-	-	112,0
25	-	-	-	-	-	-	-	-	-	-	81,3	90,3	99,4	108,4	117,4	126,4	135,5	144,5	153,5	162,6	171,6	175,0	-	-	175,0
28	-	-	-	-	-	-	-	-	-	-	-	101,2	111,3	121,4	131,5	141,6	151,7	161,9	172,0	182,1	192,2	202,3	219,5	-	219,5
32	-	-	-	-	-	-	-	-	-	-	-	-	-	138,7	150,3	161,9	173,4	185,0	196,5	208,1	219,7	231,2	286,7	286,7	286,7
40	-	-	-	-	-	-	-	-	-	-	-	-	-	-	-	-	188,5	201,1	213,6	226,2	238,8	251,3	-	-	448,0

OVERLAP SPLICE – DESIGN RESISTANCE – CONCRETE C50/60, NOMINAL YIELD STRENGTH FOR TENSION - $f_{yk} = 410$ [N/mm ²]																									
$\frac{l_b}{d_s}$	200	220	240	260	280	300	325	350	375	400	450	500	550	600	650	700	750	800	850	900	950	1000	1250	1500	Steel Failure
8	17,9	17,9	17,9	17,9	17,9	17,9	17,9	17,9	17,9	17,9	-	-	-	-	-	-	-	-	-	-	-	-	-	-	17,9
10	27,0	28,0	28,0	28,0	28,0	28,0	28,0	28,0	28,0	28,0	28,0	28,0	-	-	-	-	-	-	-	-	-	-	-	-	28,0
12	30,2	33,2	36,2	39,2	40,3	40,3	40,3	40,3	40,3	40,3	40,3	40,3	40,3	40,3	-	-	-	-	-	-	-	-	-	-	40,3
14	-	38,7	42,2	45,7	49,3	52,8	54,9	54,9	54,9	54,9	54,9	54,9	54,9	54,9	54,9	54,9	-	-	-	-	-	-	-	-	54,9
16	-	-	44,6	48,4	52,1	55,8	60,4	65,1	69,7	71,7	71,7	71,7	71,7	71,7	71,7	71,7	71,7	71,7	-	-	-	-	-	-	71,7
20	-	-	-	-	-	69,7	75,6	81,4	87,2	93,0	104,6	112,0	112,0	112,0	112,0	112,0	112,0	112,0	112,0	112,0	112,0	112,0	-	-	112,0
25	-	-	-	-	-	-	-	-	100,1	106,8	120,2	133,5	146,9	160,2	173,6	175,0	175,0	175,0	175,0	175,0	175,0	175,0	-	-	175,0
28	-	-	-	-	-	-	-	-	-	134,6	149,5	164,5	179,4	194,4	209,4	219,5	219,5	219,5	219,5	219,5	219,5	219,5	219,5	-	219,5
32	-	-	-	-	-	-	-	-	-	-	150,8	165,9	181,0	196,0	211,1	226,2	241,3	256,4	271,4	286,5	286,7	286,7	286,7	286,7	286,7
40	-	-	-	-	-	-	-	-	-	-	-	-	-	-	187,9	202,3	216,8	231,2	245,7	260,1	274,6	289,0	-	-	448,0

ANCHORAGES – DESIGN RESISTANCE – CONCRETE C20/25, NOMINAL YIELD STRENGTH FOR TENSION - $f_{yk} = 420$ [N/mm ²]																									
$\frac{l_{bd}}{d_s}$	100	120	140	160	180	200	250	300	350	400	450	500	550	600	650	700	750	800	850	900	950	1000	1250	1500	Steel Failure
8	5,8	6,9	8,1	9,2	10,4	11,6	14,5	17,3	18,4	18,4	-	-	-	-	-	-	-	-	-	-	-	-	-	-	18,4
10	-	8,7	10,1	11,6	13,0	14,5	18,1	21,7	25,3	28,7	28,7	28,7	-	-	-	-	-	-	-	-	-	-	-	-	28,7
12	-	-	-	13,9	15,6	17,3	21,7	26,0	30,3	34,7	39,0	41,3	41,3	41,3	-	-	-	-	-	-	-	-	-	-	41,3
14	-	-	-	-	18,2	20,2	25,3	30,3	35,4	40,5	45,5	50,6	55,6	56,2	56,2	56,2	-	-	-	-	-	-	-	-	56,2
16	-	-	-	-	-	23,1	28,9	34,7	40,5	46,2	52,0	57,8	63,6	69,4	73,4	73,4	73,4	73,4	-	-	-	-	-	-	73,4
20	-	-	-	-	-	-	36,1	43,4	50,6	57,8	65,0	72,3	79,5	86,7	93,9	101,2	108,4	114,8	114,8	114,8	114,8	114,8	-	-	114,8
25	-	-	-	-	-	-	-	54,2	63,2	72,3	81,3	90,3	99,4	108,4	117,4	126,4	135,5	144,5	153,5	162,6	171,6	179,3	-	-	179,3
28	-	-	-	-	-	-	-	-	70,8	80,9	91,0	101,2	111,3	121,4	131,5	141,6	151,7	161,9	172,0	182,1	192,2	202,3	224,9	-	224,9
32	-	-	-	-	-	-	-	-	-	92,5	104,0	115,6	127,2	138,7	150,3	161,9	173,4	185,0	196,5	208,1	219,7	231,2	289,0	293,7	293,7
40	-	-	-	-	-	-	-	-	-	-	-	-	138,2	150,8	163,4	175,9	188,5	201,1	213,6	226,2	238,8	251,3	-	-	458,9

Basic performance data (cont.)

ANCHORAGES – DESIGN RESISTANCE – CONCRETE C50/60, NOMINAL YIELD STRENGTH FOR TENSION - $f_{yk} = 420$ [N/mm ²]																										
l_{bd} [mm]	d_s [mm]	100	120	140	160	180	200	250	300	350	400	450	500	550	600	650	700	750	800	850	900	950	1000	1250	1500	Steel failure
8		10,8	13,0	15,1	17,3	18,4	18,4	18,4	18,4	18,4	-	-	-	-	-	-	-	-	-	-	-	-	-	-	-	18,4
10		13,5	16,2	18,9	21,6	24,3	27,0	28,7	28,7	28,7	28,7	28,7	28,7	-	-	-	-	-	-	-	-	-	-	-	-	28,7
12		-	18,1	21,1	24,1	27,1	30,2	37,7	41,3	41,3	41,3	41,3	41,3	41,3	-	-	-	-	-	-	-	-	-	-	-	41,3
14		-	-	24,6	28,1	31,7	35,2	44,0	52,8	56,2	56,2	56,2	56,2	56,2	56,2	56,2	-	-	-	-	-	-	-	-	-	56,2
16		-	-	-	29,8	33,5	37,2	46,5	55,8	65,1	73,4	73,4	73,4	73,4	73,4	73,4	73,4	73,4	-	-	-	-	-	-	-	73,4
20		-	-	-	-	-	46,5	58,1	69,7	81,4	93,0	104,6	114,8	114,8	114,8	114,8	114,8	114,8	114,8	114,8	114,8	114,8	114,8	-	-	114,8
25		-	-	-	-	-	-	66,8	80,1	93,5	106,8	120,2	133,5	146,9	160,2	173,6	179,3	179,3	179,3	179,3	179,3	179,3	179,3	-	-	179,3
28		-	-	-	-	-	-	-	89,7	104,7	119,6	134,6	149,5	164,5	179,4	194,4	209,4	224,3	224,9	224,9	224,9	224,9	224,9	224,9	-	224,9
32		-	-	-	-	-	-	-	-	105,6	120,6	135,7	150,8	165,9	181,0	196,0	211,1	226,2	241,3	256,4	271,4	286,5	293,7	293,7	293,7	293,7
40		-	-	-	-	-	-	-	-	-	-	130,1	144,5	159,0	173,4	187,9	202,3	216,8	231,2	245,7	260,1	274,6	289,0	-	-	458,9

OVERLAP SPLICE – DESIGN RESISTANCE – CONCRETE C20/25, NOMINAL YIELD STRENGTH FOR TENSION - $f_{yk} = 420$ [N/mm ²]																										
l_o [mm]	d_s [mm]	200	220	240	260	280	300	325	350	375	400	450	500	550	600	650	700	750	800	850	900	950	1000	1250	1500	Steel failure
8		11,6	12,7	13,9	15,0	16,2	17,3	18,4	18,4	18,4	18,4	-	-	-	-	-	-	-	-	-	-	-	-	-	-	18,4
10		14,5	15,9	17,3	18,8	20,2	21,7	23,5	25,3	27,1	28,7	28,7	28,7	-	-	-	-	-	-	-	-	-	-	-	-	28,7
12		-	19,1	20,8	22,5	24,3	26,0	28,2	30,3	32,5	34,7	39,0	41,3	41,3	41,3	-	-	-	-	-	-	-	-	-	-	41,3
14		-	-	-	26,3	28,3	30,3	32,9	35,4	37,9	40,5	45,5	50,6	55,6	56,2	56,2	56,2	-	-	-	-	-	-	-	-	56,2
16		-	-	-	-	-	34,7	37,6	40,5	43,4	46,2	52,0	57,8	63,6	69,4	73,4	73,4	73,4	73,4	-	-	-	-	-	-	73,4
20		-	-	-	-	-	-	-	-	54,2	57,8	65,0	72,3	79,5	86,7	93,9	101,2	108,4	114,8	114,8	114,8	114,8	114,8	-	-	114,8
25		-	-	-	-	-	-	-	-	-	-	81,3	90,3	99,4	108,4	117,4	126,4	135,5	144,5	153,5	162,6	171,6	179,3	-	-	179,3
28		-	-	-	-	-	-	-	-	-	-	-	-	111,3	121,4	131,5	141,6	151,7	161,9	172,0	182,1	192,2	202,3	224,9	-	224,9
32		-	-	-	-	-	-	-	-	-	-	-	-	-	138,7	150,3	161,9	173,4	185,0	196,5	208,1	219,7	231,2	289,0	293,7	293,7
40		-	-	-	-	-	-	-	-	-	-	-	-	-	-	-	-	-	201,1	213,6	226,2	238,8	251,3	-	-	458,9

OVERLAP SPLICE – DESIGN RESISTANCE – CONCRETE C50/60, NOMINAL YIELD STRENGTH FOR TENSION - $f_{yk} = 420$ [N/mm ²]																										
l_o [mm]	d_s [mm]	200	220	240	260	280	300	325	350	375	400	450	500	550	600	650	700	750	800	850	900	950	1000	1250	1500	Steel failure
8		18,4	18,4	18,4	18,4	18,4	18,4	18,4	18,4	18,4	18,4	-	-	-	-	-	-	-	-	-	-	-	-	-	-	18,4
10		27,0	28,7	28,7	28,7	28,7	28,7	28,7	28,7	28,7	28,7	28,7	28,7	-	-	-	-	-	-	-	-	-	-	-	-	28,7
12		30,2	33,2	36,2	39,2	41,3	41,3	41,3	41,3	41,3	41,3	41,3	41,3	41,3	-	-	-	-	-	-	-	-	-	-	-	41,3
14		-	38,7	42,2	45,7	49,3	52,8	56,2	56,2	56,2	56,2	56,2	56,2	56,2	56,2	56,2	-	-	-	-	-	-	-	-	-	56,2
16		-	-	44,6	48,4	52,1	55,8	60,4	65,1	69,7	73,4	73,4	73,4	73,4	73,4	73,4	73,4	73,4	73,4	-	-	-	-	-	-	73,4
20		-	-	-	-	-	69,7	75,6	81,4	87,2	93,0	104,6	114,8	114,8	114,8	114,8	114,8	114,8	114,8	114,8	114,8	114,8	114,8	-	-	114,8
25		-	-	-	-	-	-	-	-	100,1	106,8	120,2	133,5	146,9	160,2	173,6	179,3	179,3	179,3	179,3	179,3	179,3	179,3	-	-	179,3
28		-	-	-	-	-	-	-	-	-	-	134,6	149,5	164,5	179,4	194,4	209,4	224,3	224,9	224,9	224,9	224,9	224,9	224,9	-	224,9
32		-	-	-	-	-	-	-	-	-	-	-	150,8	165,9	181,0	196,0	211,1	226,2	241,3	256,4	271,4	286,5	293,7	293,7	293,7	293,7
40		-	-	-	-	-	-	-	-	-	-	-	-	-	-	-	202,3	216,8	231,2	245,7	260,1	274,6	289,0	-	-	458,9

Basic performance data (cont.)

ANCHORAGES – DESIGN RESISTANCE – CONCRETE C20/25, NOMINAL YIELD STRENGTH FOR TENSION - $f_{yk} = 460$ [N/mm ²]																										
$\frac{l_{bd}}{d_s}$	100	120	140	160	180	200	250	300	350	400	450	500	550	600	650	700	750	800	850	900	950	1000	1250	1500	Steel Failure	
8	-	6,9	8,1	9,2	10,4	11,6	14,5	17,3	20,1	20,1	-	-	-	-	-	-	-	-	-	-	-	-	-	-	-	20,1
10	-	-	10,1	11,6	13,0	14,5	18,1	21,7	25,3	28,9	31,4	31,4	-	-	-	-	-	-	-	-	-	-	-	-	-	31,4
12	-	-	-	13,9	15,6	17,3	21,7	26,0	30,3	34,7	39,0	43,4	45,2	45,2	-	-	-	-	-	-	-	-	-	-	-	45,2
14	-	-	-	-	-	20,2	25,3	30,3	35,4	40,5	45,5	50,6	55,6	60,7	61,6	61,6	-	-	-	-	-	-	-	-	-	61,6
16	-	-	-	-	-	-	28,9	34,7	40,5	46,2	52,0	57,8	63,6	69,4	75,1	80,4	80,4	80,4	-	-	-	-	-	-	-	80,4
20	-	-	-	-	-	-	-	43,4	50,6	57,8	65,0	72,3	79,5	86,7	93,9	101,2	108,4	115,6	122,8	125,7	125,7	125,7	-	-	-	125,7
25	-	-	-	-	-	-	-	-	63,2	72,3	81,3	90,3	99,4	108,4	117,4	126,4	135,5	144,5	153,5	162,6	171,6	180,6	-	-	-	196,4
28	-	-	-	-	-	-	-	-	-	80,9	91,0	101,2	111,3	121,4	131,5	141,6	151,7	161,9	172,0	182,1	192,2	202,3	246,3	-	-	246,3
32	-	-	-	-	-	-	-	-	-	-	104,0	115,6	127,2	138,7	150,3	161,9	173,4	185,0	196,5	208,1	219,7	231,2	289,0	321,7	-	321,7
40	-	-	-	-	-	-	-	-	-	-	-	-	-	150,8	163,4	175,9	188,5	201,1	213,6	226,2	238,8	251,3	-	-	-	502,6

ANCHORAGES – DESIGN RESISTANCE – CONCRETE C50/60, NOMINAL YIELD STRENGTH FOR TENSION - $f_{yk} = 460$ [N/mm ²]																										
$\frac{l_{bd}}{d_s}$	100	120	140	160	180	200	250	300	350	400	450	500	550	600	650	700	750	800	850	900	950	1000	1250	1500	Steel Failure	
8	10,8	13,0	15,1	17,3	19,5	20,1	20,1	20,1	20,1	20,1	-	-	-	-	-	-	-	-	-	-	-	-	-	-	-	20,1
10	13,5	16,2	18,9	21,6	24,3	27,0	31,4	31,4	31,4	31,4	31,4	31,4	-	-	-	-	-	-	-	-	-	-	-	-	-	31,4
12	-	18,1	21,1	24,1	27,1	30,2	37,7	45,2	45,2	45,2	45,2	45,2	45,2	-	-	-	-	-	-	-	-	-	-	-	-	45,2
14	-	-	24,6	28,1	31,7	35,2	44,0	52,8	61,6	61,6	61,6	61,6	61,6	61,6	61,6	61,6	-	-	-	-	-	-	-	-	-	61,6
16	-	-	-	29,8	33,5	37,2	46,5	55,8	65,1	74,4	80,4	80,4	80,4	80,4	80,4	80,4	80,4	80,4	-	-	-	-	-	-	-	80,4
20	-	-	-	-	-	46,5	58,1	69,7	81,4	93,0	104,6	116,2	125,7	125,7	125,7	125,7	125,7	125,7	125,7	125,7	125,7	125,7	-	-	-	125,7
25	-	-	-	-	-	-	66,8	80,1	93,5	106,8	120,2	133,5	146,9	160,2	173,6	186,9	196,4	196,4	196,4	196,4	196,4	196,4	-	-	-	196,4
28	-	-	-	-	-	-	-	89,7	104,7	119,6	134,6	149,5	164,5	179,4	194,4	209,4	224,3	239,3	246,3	246,3	246,3	246,3	246,3	246,3	-	246,3
32	-	-	-	-	-	-	-	-	105,6	120,6	135,7	150,8	165,9	181,0	196,0	211,1	226,2	241,3	256,4	271,4	286,5	301,6	321,7	321,7	-	321,7
40	-	-	-	-	-	-	-	-	-	-	-	144,5	159,0	173,4	187,9	202,3	216,8	231,2	245,7	260,1	274,6	289,0	-	-	-	502,6

OVERLAP SPLICE – DESIGN RESISTANCE – CONCRETE C20/25, NOMINAL YIELD STRENGTH FOR TENSION - $f_{yk} = 460$ [N/mm ²]																										
$\frac{l_o}{d_s}$	200	220	240	260	280	300	325	350	375	400	450	500	550	600	650	700	750	800	850	900	950	1000	1250	1500	Steel Failure	
8	11,6	12,7	13,9	15,0	16,2	17,3	18,8	20,1	20,1	20,1	-	-	-	-	-	-	-	-	-	-	-	-	-	-	-	20,1
10	14,5	15,9	17,3	18,8	20,2	21,7	23,5	25,3	27,1	28,9	31,4	31,4	-	-	-	-	-	-	-	-	-	-	-	-	-	31,4
12	-	-	20,8	22,5	24,3	26,0	28,2	30,3	32,5	34,7	39,0	43,4	45,2	45,2	-	-	-	-	-	-	-	-	-	-	-	45,2
14	-	-	-	-	28,3	30,3	32,9	35,4	37,9	40,5	45,5	50,6	55,6	60,7	61,6	61,6	-	-	-	-	-	-	-	-	-	61,6
16	-	-	-	-	-	-	37,6	40,5	43,4	46,2	52,0	57,8	63,6	69,4	75,1	80,4	80,4	80,4	-	-	-	-	-	-	-	80,4
20	-	-	-	-	-	-	-	-	-	57,8	65,0	72,3	79,5	86,7	93,9	101,2	108,4	115,6	122,8	125,7	125,7	125,7	-	-	-	125,7
25	-	-	-	-	-	-	-	-	-	-	90,3	99,4	108,4	117,4	126,4	135,5	144,5	153,5	162,6	171,6	180,6	-	-	-	-	196,4
28	-	-	-	-	-	-	-	-	-	-	-	111,3	121,4	131,5	141,6	151,7	161,9	172,0	182,1	192,2	202,3	246,3	-	-	-	246,3
32	-	-	-	-	-	-	-	-	-	-	-	-	-	-	150,3	161,9	173,4	185,0	196,5	208,1	219,7	231,2	289,0	321,7	-	321,7
40	-	-	-	-	-	-	-	-	-	-	-	-	-	-	-	-	-	-	-	213,6	226,2	238,8	251,3	-	-	502,6

Basic performance data (cont.)

OVERLAP SPLICE – DESIGN RESISTANCE – CONCRETE C50/60, NOMINAL YIELD STRENGTH FOR TENSION - $f_{yk} = 460$ [N/mm ²]																										
l_b [mm]	d_s [mm]	200	220	240	260	280	300	325	350	375	400	450	500	550	600	650	700	750	800	850	900	950	1000	1250	1500	Steel failure
8		20,1	20,1	20,1	20,1	20,1	20,1	20,1	20,1	20,1	-	-	-	-	-	-	-	-	-	-	-	-	-	-	-	20,1
10		27,0	29,7	31,4	31,4	31,4	31,4	31,4	31,4	31,4	31,4	31,4	-	-	-	-	-	-	-	-	-	-	-	-	-	31,4
12		30,2	33,2	36,2	39,2	42,2	45,2	45,2	45,2	45,2	45,2	45,2	45,2	45,2	-	-	-	-	-	-	-	-	-	-	-	45,2
14		-	38,7	42,2	45,7	49,3	52,8	57,2	61,6	61,6	61,6	61,6	61,6	61,6	61,6	61,6	61,6	-	-	-	-	-	-	-	-	61,6
16		-	-	44,6	48,4	52,1	55,8	60,4	65,1	69,7	74,4	80,4	80,4	80,4	80,4	80,4	80,4	80,4	80,4	-	-	-	-	-	-	80,4
20		-	-	-	-	-	69,7	75,6	81,4	87,2	93,0	104,6	116,2	125,7	125,7	125,7	125,7	125,7	125,7	125,7	125,7	125,7	125,7	-	-	125,7
25		-	-	-	-	-	-	-	-	100,1	106,8	120,2	133,5	146,9	160,2	173,6	186,9	196,4	196,4	196,4	196,4	196,4	196,4	-	-	196,4
28		-	-	-	-	-	-	-	-	-	-	134,6	149,5	164,5	179,4	194,4	209,4	224,3	239,3	246,3	246,3	246,3	246,3	246,3	-	246,3
32		-	-	-	-	-	-	-	-	-	-	-	150,8	165,9	181,0	196,0	211,1	226,2	241,3	256,4	271,4	286,5	301,6	321,7	321,7	321,7
40		-	-	-	-	-	-	-	-	-	-	-	-	-	-	-	-	216,8	231,2	245,7	260,1	274,6	289,0	-	-	502,6

ANCHORAGES – DESIGN RESISTANCE – CONCRETE C20/25, NOMINAL YIELD STRENGTH FOR TENSION - $f_{yk} = 500$ [N/mm ²]																										
l_b [mm]	d_s [mm]	100	120	140	160	180	200	250	300	350	400	450	500	550	600	650	700	750	800	850	900	950	1000	1250	1500	Steel failure
8		-	6,9	8,1	9,2	10,4	11,6	14,5	17,3	20,2	21,9	-	-	-	-	-	-	-	-	-	-	-	-	-	-	21,9
10		-	-	-	11,6	13,0	14,5	18,1	21,7	25,3	28,9	32,5	34,1	-	-	-	-	-	-	-	-	-	-	-	-	34,1
12		-	-	-	-	15,6	17,3	21,7	26,0	30,3	34,7	39,0	43,4	47,7	49,2	-	-	-	-	-	-	-	-	-	-	49,2
14		-	-	-	-	-	20,2	25,3	30,3	35,4	40,5	45,5	50,6	55,6	60,7	65,8	66,9	-	-	-	-	-	-	-	-	66,9
16		-	-	-	-	-	-	28,9	34,7	40,5	46,2	52,0	57,8	63,6	69,4	75,1	80,9	86,7	87,4	-	-	-	-	-	-	87,4
20		-	-	-	-	-	-	-	43,4	50,6	57,8	65,0	72,3	79,5	86,7	93,9	101,2	108,4	115,6	122,8	130,1	136,6	136,6	-	-	136,6
25		-	-	-	-	-	-	-	-	-	72,3	81,3	90,3	99,4	108,4	117,4	126,4	135,5	144,5	153,5	162,6	171,6	180,6	-	-	213,4
28		-	-	-	-	-	-	-	-	-	80,9	91,0	101,2	111,3	121,4	131,5	141,6	151,7	161,9	172,0	182,1	192,2	202,3	252,9	-	267,7
32		-	-	-	-	-	-	-	-	-	-	-	115,6	127,2	138,7	150,3	161,9	173,4	185,0	196,5	208,1	219,7	231,2	289,0	346,8	349,7
40		-	-	-	-	-	-	-	-	-	-	-	-	-	150,8	163,4	175,9	188,5	201,1	213,6	226,2	238,8	251,3	-	-	546,3

ANCHORAGES – DESIGN RESISTANCE – CONCRETE C50/60, NOMINAL YIELD STRENGTH FOR TENSION - $f_{yk} = 500$ [N/mm ²]																										
l_b [mm]	d_s [mm]	100	120	140	160	180	200	250	300	350	400	450	500	550	600	650	700	750	800	850	900	950	1000	1250	1500	Steel failure
8		10,8	13,0	15,1	17,3	19,5	21,6	21,9	21,9	21,9	21,9	-	-	-	-	-	-	-	-	-	-	-	-	-	-	21,9
10		13,5	16,2	18,9	21,6	24,3	27,0	33,8	34,1	34,1	34,1	34,1	34,1	-	-	-	-	-	-	-	-	-	-	-	-	34,1
12		-	18,1	21,1	24,1	27,1	30,2	37,7	45,2	49,2	49,2	49,2	49,2	49,2	49,2	-	-	-	-	-	-	-	-	-	-	49,2
14		-	-	24,6	28,1	31,7	35,2	44,0	52,8	61,6	66,9	66,9	66,9	66,9	66,9	66,9	66,9	-	-	-	-	-	-	-	-	66,9
16		-	-	-	29,8	33,5	37,2	46,5	55,8	65,1	74,4	83,7	87,4	87,4	87,4	87,4	87,4	87,4	87,4	-	-	-	-	-	-	87,4
20		-	-	-	-	-	46,5	58,1	69,7	81,4	93,0	104,6	116,2	127,9	136,6	136,6	136,6	136,6	136,6	136,6	136,6	136,6	136,6	-	-	136,6
25		-	-	-	-	-	-	66,8	80,1	93,5	106,8	120,2	133,5	146,9	160,2	173,6	186,9	200,3	213,4	213,4	213,4	213,4	213,4	-	-	213,4
28		-	-	-	-	-	-	-	89,7	104,7	119,6	134,6	149,5	164,5	179,4	194,4	209,4	224,3	239,3	254,2	267,7	267,7	267,7	267,7	-	267,7
32		-	-	-	-	-	-	-	-	105,6	120,6	135,7	150,8	165,9	181,0	196,0	211,1	226,2	241,3	256,4	271,4	286,5	301,6	349,7	349,7	349,7
40		-	-	-	-	-	-	-	-	-	-	-	-	159,0	173,4	187,9	202,3	216,8	231,2	245,7	260,1	274,6	289,0	-	-	546,3

Basic performance data (cont.)

OVERLAP SPLICE – DESIGN RESISTANCE – CONCRETE C20/25, NOMINAL YIELD STRENGTH FOR TENSION - $f_{yk} = 500$ [N/mm ²]																										
$\frac{l_0}{d_s}$ [mm]	200	220	240	260	280	300	325	350	375	400	450	500	550	600	650	700	750	800	850	900	950	1000	1250	1500	Steel failure	
8	11,6	12,7	13,9	15,0	16,2	17,3	18,8	20,2	21,7	21,9	-	-	-	-	-	-	-	-	-	-	-	-	-	-	-	21,9
10	-	15,9	17,3	18,8	20,2	21,7	23,5	25,3	27,1	28,9	32,5	34,1	-	-	-	-	-	-	-	-	-	-	-	-	-	34,1
12	-	-	-	22,5	24,3	26,0	28,2	30,3	32,5	34,7	39,0	43,4	47,7	49,2	-	-	-	-	-	-	-	-	-	-	-	49,2
14	-	-	-	-	-	30,3	32,9	35,4	37,9	40,5	45,5	50,6	55,6	60,7	65,8	66,9	-	-	-	-	-	-	-	-	-	66,9
16	-	-	-	-	-	-	-	40,5	43,4	46,2	52,0	57,8	63,6	69,4	75,1	80,9	86,7	87,4	-	-	-	-	-	-	-	87,4
20	-	-	-	-	-	-	-	-	-	-	65,0	72,3	79,5	86,7	93,9	101,2	108,4	115,6	122,8	130,1	136,6	136,6	-	-	-	136,6
25	-	-	-	-	-	-	-	-	-	-	-	-	99,4	108,4	117,4	126,4	135,5	144,5	153,5	162,6	171,6	180,6	-	-	-	213,4
28	-	-	-	-	-	-	-	-	-	-	-	-	-	121,4	131,5	141,6	151,7	161,9	172,0	182,1	192,2	202,3	252,9	-	-	267,7
32	-	-	-	-	-	-	-	-	-	-	-	-	-	-	-	161,9	173,4	185,0	196,5	208,1	219,7	231,2	289,0	346,8	-	349,7
40	-	-	-	-	-	-	-	-	-	-	-	-	-	-	-	-	-	-	-	226,2	238,8	251,3	-	-	-	546,3

OVERLAP SPLICE – DESIGN RESISTANCE – CONCRETE C50/60, NOMINAL YIELD STRENGTH FOR TENSION - $f_{yk} = 500$ [N/mm ²]																										
$\frac{l_0}{d_s}$ [mm]	200	220	240	260	280	300	325	350	375	400	450	500	550	600	650	700	750	800	850	900	950	1000	1250	1500	Steel failure	
8	21,6	21,9	21,9	21,9	21,9	21,9	21,9	21,9	21,9	21,9	-	-	-	-	-	-	-	-	-	-	-	-	-	-	-	21,9
10	27,0	29,7	32,4	34,1	34,1	34,1	34,1	34,1	34,1	34,1	34,1	34,1	-	-	-	-	-	-	-	-	-	-	-	-	-	34,1
12	30,2	33,2	36,2	39,2	42,2	45,2	49,0	49,2	49,2	49,2	49,2	49,2	49,2	49,2	-	-	-	-	-	-	-	-	-	-	-	49,2
14	-	38,7	42,2	45,7	49,3	52,8	57,2	61,6	66,0	66,9	66,9	66,9	66,9	66,9	66,9	66,9	-	-	-	-	-	-	-	-	-	66,9
16	-	-	44,6	48,4	52,1	55,8	60,4	65,1	69,7	74,4	83,7	87,4	87,4	87,4	87,4	87,4	87,4	87,4	-	-	-	-	-	-	-	87,4
20	-	-	-	-	-	69,7	75,6	81,4	87,2	93,0	104,6	116,2	127,9	136,6	136,6	136,6	136,6	136,6	136,6	136,6	136,6	136,6	-	-	-	136,6
25	-	-	-	-	-	-	-	-	100,1	106,8	120,2	133,5	146,9	160,2	173,6	186,9	200,3	213,4	213,4	213,4	213,4	213,4	-	-	-	213,4
28	-	-	-	-	-	-	-	-	-	134,6	149,5	164,5	179,4	194,4	209,4	224,3	239,3	254,2	267,7	267,7	267,7	267,7	267,7	-	-	267,7
32	-	-	-	-	-	-	-	-	-	-	-	165,9	181,0	196,0	211,1	226,2	241,3	256,4	271,4	286,5	301,6	349,7	349,7	-	-	349,7
40	-	-	-	-	-	-	-	-	-	-	-	-	-	-	-	-	-	231,2	245,7	260,1	274,6	289,0	-	-	-	546,3

ANCHORAGES – DESIGN RESISTANCE – CONCRETE C20/25, NOMINAL YIELD STRENGTH FOR TENSION - $f_{yk} = 600$ [N/mm ²]																										
$\frac{l_0}{d_s}$ [mm]	100	120	140	160	180	200	250	300	350	400	450	500	550	600	650	700	750	800	850	900	950	1000	1250	1500	Steel failure	
8	-	-	8,1	9,2	10,4	11,6	14,5	17,3	20,2	23,1	-	-	-	-	-	-	-	-	-	-	-	-	-	-	-	26,2
10	-	-	-	-	13,0	14,5	18,1	21,7	25,3	28,9	32,5	36,1	-	-	-	-	-	-	-	-	-	-	-	-	-	41,0
12	-	-	-	-	-	-	21,7	26,0	30,3	34,7	39,0	43,4	47,7	52,0	-	-	-	-	-	-	-	-	-	-	-	59,0
14	-	-	-	-	-	-	25,3	30,3	35,4	40,5	45,5	50,6	55,6	60,7	65,8	70,8	-	-	-	-	-	-	-	-	-	80,3
16	-	-	-	-	-	-	-	34,7	40,5	46,2	52,0	57,8	63,6	69,4	75,1	80,9	86,7	92,5	-	-	-	-	-	-	-	104,9
20	-	-	-	-	-	-	-	-	50,6	57,8	65,0	72,3	79,5	86,7	93,9	101,2	108,4	115,6	122,8	130,1	137,3	144,5	-	-	-	163,9
25	-	-	-	-	-	-	-	-	-	-	81,3	90,3	99,4	108,4	117,4	126,4	135,5	144,5	153,5	162,6	171,6	180,6	-	-	-	256,1
28	-	-	-	-	-	-	-	-	-	-	-	101,2	111,3	121,4	131,5	141,6	151,7	161,9	172,0	182,1	192,2	202,3	252,9	-	-	321,3
32	-	-	-	-	-	-	-	-	-	-	-	-	127,2	138,7	150,3	161,9	173,4	185,0	196,5	208,1	219,7	231,2	289,0	346,8	-	419,6
40	-	-	-	-	-	-	-	-	-	-	-	-	-	-	-	-	188,5	201,1	213,6	226,2	238,8	251,3	-	-	-	655,6

Basic performance data (cont.)

ANCHORAGES – DESIGN RESISTANCE – CONCRETE C50/60, NOMINAL YIELD STRENGTH FOR TENSION - $f_{yk} = 600$ [N/mm ²]																									
l_0 [mm]	100	120	140	160	180	200	250	300	350	400	450	500	550	600	650	700	750	800	850	900	950	1000	1250	1500	Steel failure
d_s [mm]	100	120	140	160	180	200	250	300	350	400	450	500	550	600	650	700	750	800	850	900	950	1000	1250	1500	Steel failure
8	10,8	13,0	15,1	17,3	19,5	21,6	26,2	26,2	26,2	26,2	-	-	-	-	-	-	-	-	-	-	-	-	-	-	26,2
10	13,5	16,2	18,9	21,6	24,3	27,0	33,8	40,5	41,0	41,0	41,0	41,0	-	-	-	-	-	-	-	-	-	-	-	-	41,0
12	-	18,1	21,1	24,1	27,1	30,2	37,7	45,2	52,8	59,0	59,0	59,0	59,0	-	-	-	-	-	-	-	-	-	-	-	59,0
14	-	-	24,6	28,1	31,7	35,2	44,0	52,8	61,6	70,4	79,2	80,3	80,3	80,3	80,3	-	-	-	-	-	-	-	-	-	80,3
16	-	-	-	-	33,5	37,2	46,5	55,8	65,1	74,4	83,7	93,0	102,3	104,9	104,9	104,9	104,9	104,9	-	-	-	-	-	-	104,9
20	-	-	-	-	-	-	58,1	69,7	81,4	93,0	104,6	116,2	127,9	139,5	151,1	162,7	163,9	163,9	163,9	163,9	163,9	163,9	-	-	163,9
25	-	-	-	-	-	-	-	80,1	93,5	106,8	120,2	133,5	146,9	160,2	173,6	186,9	200,3	213,6	227,0	240,3	253,7	256,1	-	-	256,1
28	-	-	-	-	-	-	-	-	104,7	119,6	134,6	149,5	164,5	179,4	194,4	209,4	224,3	239,3	254,2	269,2	284,1	299,1	321,3	-	321,3
32	-	-	-	-	-	-	-	-	-	-	135,7	150,8	165,9	181,0	196,0	211,1	226,2	241,3	256,4	271,4	286,5	301,6	377,0	419,6	419,6
40	-	-	-	-	-	-	-	-	-	-	-	-	-	-	187,9	202,3	216,8	231,2	245,7	260,1	274,6	289,0	-	-	655,6

OVERLAP SPLICE – DESIGN RESISTANCE – CONCRETE C20/25, NOMINAL YIELD STRENGTH FOR TENSION - $f_{yk} = 600$ [N/mm ²]																									
l_0 [mm]	200	220	240	260	280	300	325	350	375	400	450	500	550	600	650	700	750	800	850	900	950	1000	1250	1500	Steel failure
d_s [mm]	200	220	240	260	280	300	325	350	375	400	450	500	550	600	650	700	750	800	850	900	950	1000	1250	1500	Steel failure
8	-	12,7	13,9	15,0	16,2	17,3	18,8	20,2	21,7	23,1	-	-	-	-	-	-	-	-	-	-	-	-	-	-	26,2
10	-	-	-	18,8	20,2	21,7	23,5	25,3	27,1	28,9	32,5	36,1	-	-	-	-	-	-	-	-	-	-	-	-	41,0
12	-	-	-	-	-	-	28,2	30,3	32,5	34,7	39,0	43,4	47,7	52,0	-	-	-	-	-	-	-	-	-	-	59,0
14	-	-	-	-	-	-	-	-	37,9	40,5	45,5	50,6	55,6	60,7	65,8	70,8	-	-	-	-	-	-	-	-	80,3
16	-	-	-	-	-	-	-	-	-	-	52,0	57,8	63,6	69,4	75,1	80,9	86,7	92,5	-	-	-	-	-	-	104,9
20	-	-	-	-	-	-	-	-	-	-	-	-	79,5	86,7	93,9	101,2	108,4	115,6	122,8	130,1	137,3	144,5	-	-	163,9
25	-	-	-	-	-	-	-	-	-	-	-	-	-	-	117,4	126,4	135,5	144,5	153,5	162,6	171,6	180,6	-	-	256,1
28	-	-	-	-	-	-	-	-	-	-	-	-	-	-	-	-	151,7	161,9	172,0	182,1	192,2	202,3	252,9	-	321,3
32	-	-	-	-	-	-	-	-	-	-	-	-	-	-	-	-	-	-	196,5	208,1	219,7	231,2	289,0	346,8	419,6
40	-	-	-	-	-	-	-	-	-	-	-	-	-	-	-	-	-	-	-	-	-	-	-	-	655,6

OVERLAP SPLICE – DESIGN RESISTANCE – CONCRETE C50/60, NOMINAL YIELD STRENGTH FOR TENSION - $f_{yk} = 600$ [N/mm ²]																									
l_0 [mm]	200	220	240	260	280	300	325	350	375	400	450	500	550	600	650	700	750	800	850	900	950	1000	1250	1500	Steel failure
d_s [mm]	200	220	240	260	280	300	325	350	375	400	450	500	550	600	650	700	750	800	850	900	950	1000	1250	1500	Steel failure
8	21,6	23,8	25,9	26,2	26,2	26,2	26,2	26,2	26,2	26,2	-	-	-	-	-	-	-	-	-	-	-	-	-	-	26,2
10	27,0	29,7	32,4	35,1	37,8	40,5	41,0	41,0	41,0	41,0	41,0	41,0	-	-	-	-	-	-	-	-	-	-	-	-	41,0
12	30,2	33,2	36,2	39,2	42,2	45,2	49,0	52,8	56,5	59,0	59,0	59,0	59,0	-	-	-	-	-	-	-	-	-	-	-	59,0
14	-	38,7	42,2	45,7	49,3	52,8	57,2	61,6	66,0	70,4	79,2	80,3	80,3	80,3	80,3	-	-	-	-	-	-	-	-	-	80,3
16	-	-	-	48,4	52,1	55,8	60,4	65,1	69,7	74,4	83,7	93,0	102,3	104,9	104,9	104,9	104,9	104,9	-	-	-	-	-	-	104,9
20	-	-	-	-	-	-	75,6	81,4	87,2	93,0	104,6	116,2	127,9	139,5	151,1	162,7	163,9	163,9	163,9	163,9	163,9	163,9	-	-	163,9
25	-	-	-	-	-	-	-	-	-	-	120,2	133,5	146,9	160,2	173,6	186,9	200,3	213,6	227,0	240,3	253,7	256,1	-	-	256,1
28	-	-	-	-	-	-	-	-	-	-	-	149,5	164,5	179,4	194,4	209,4	224,3	239,3	254,2	269,2	284,1	299,1	321,3	-	321,3
32	-	-	-	-	-	-	-	-	-	-	-	-	-	-	196,0	211,1	226,2	241,3	256,4	271,4	286,5	301,6	377,0	419,6	419,6
40	-	-	-	-	-	-	-	-	-	-	-	-	-	-	-	-	-	-	-	-	274,6	289,0	-	-	655,6

Basic performance data (cont.)

POST INSTALLED REBARS

Size			Ø8	Ø10	Ø12	Ø14	Ø16	Ø20	Ø25	Ø28	Ø32	Ø40
DESIGN LOAD												
Mean ultimate bond resistance C12/15	f_{bd}	[N/mm ²]	1.60	1.60	1.60	1.60	1.60	1.60	1.60	1.60	1.60	1.60
Mean ultimate bond resistance C16/20	f_{bd}	[N/mm ²]	2.00	2.00	2.00	2.00	2.00	2.00	2.00	2.00	2.00	2.00
Mean ultimate bond resistance C20/25	f_{bd}	[N/mm ²]	2.30	2.30	2.30	2.30	2.30	2.30	2.30	2.30	2.30	2.00
Mean ultimate bond resistance C25/30	f_{bd}	[N/mm ²]	2.70	2.70	2.70	2.70	2.70	2.70	2.70	2.70	2.70	2.00
Mean ultimate bond resistance C30/37	f_{bd}	[N/mm ²]	3.00	3.00	3.00	3.00	3.00	3.00	3.00	3.00	2.70	2.00
Mean ultimate bond resistance C35/45	f_{bd}	[N/mm ²]	3.40	3.40	3.40	3.40	3.40	3.40	3.00	3.00	3.00	2.00
Mean ultimate bond resistance C40/50	f_{bd}	[N/mm ²]	3.70	3.70	3.70	3.70	3.70	3.40	3.00	3.00	3.00	2.30
Mean ultimate bond resistance C45/55	f_{bd}	[N/mm ²]	4.00	4.00	4.00	3.70	3.70	3.40	3.40	3.00	3.00	2.30
Mean ultimate bond resistance C50/60	f_{bd}	[N/mm ²]	4.30	4.30	4.00	4.00	3.70	3.70	3.40	3.40	3.00	2.30

Product commercial data

Product Code	Volume [m ³]	Quantity [pcs]			Weight [kg]			Bar Code
		Box	Outer	Pallet	Box	Outer	Pallet	
R-KER-II-300-S ¹⁾	300	10	10	840	5.2	5.2	466.8	5906675432045
R-KER-II-400-S ¹⁾	400	10	10	560	8.2	8.2	489.2	5906675432076

¹⁾ ETA-17/0874

R-KER with Threaded Rods

High performance vinylester resin approved for use in cracked and non-cracked concrete



Installation movie



Approvals and Reports

• ETA-10/0055



Product overview

Features and benefits

- Approved for use with threaded rods for use in cracked and non-cracked concrete
- Suitable for use in low temperatures (down to -20°C for winter option) enables use throughout the year
- Winter version can be used in warmer temperatures for faster curing
- Suitable for use in dry and wet substrates as well as holes and substrates covered with water
- Rapid bonding time enables quick execution of works
- Very high load capacity
- Anchor does not generate tensions in the substrate which enables R-KER to be specified where closer edge and spacing distances are required

Applications

- Curtain walling
- Balustrading
- Handrails
- Canopies
- Large panel reinforcing system -Copy Eco
- Cable conduits and trays
- Fencing & gates manufacturing and installation
- Pipework/ductwork supports
- Platforms
- Pipelines systems
- Passenger lifts

Base materials

Approved for use in:

- Cracked concrete C20/25-C50/60
- Non-cracked concrete C20/25-C50/60

Installation guide

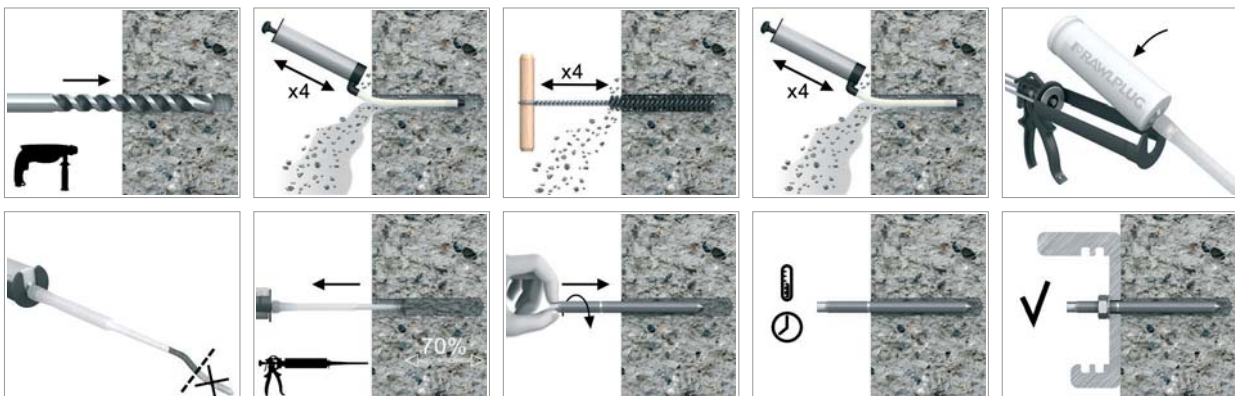

All products listed in this publication are branded and distributed with RAWLPLUG® or RAWL® trademarks.

Installation guide (cont.)

1. Drill hole to the required diameter and depth for stud size being used.
2. Clean the drill hole thoroughly with brush and hand pump at least four times before installation.
3. Attach nozzle and insert cartridge into gun.
4. Dispense to waste until even colour is obtained.
5. Insert the mixer nozzle to the bottom of the drill hole and inject resin, slowly withdrawing the nozzle as the hole is filled to 70% of its depth.
6. Immediately insert the stud, slowly and with slight twisting motion. Remove any excess resin around the hole before it sets and leave it undisturbed until the curing time elapses.
7. Attach fixture and tighten the nut to the required torque.

Product information

Product Code	Resin	Description / Resin Type	Volume
			[m]
R-KER-300	R-KER	Styrene Free Vinylester Resin	300
R-KER-345			345
R-KER-400			400
R-KER-300-W	R-KER-W	Low Temperature (Winter) / Rapid Cure Styrene Free Vinylester Resin	300
R-KER-380-W			380
R-KER-400-S	R-KER-S	High Temperature (Summer) / Slow Cure Styrene Free Vinylester Resin	400

R-STUDS

Size	Product Code			Anchor		Fixture			
	Steel class 5.8	Steel class 8.8	Steel grade A4	Diameter	Length	Hole diameter	Max. thickness t_{fix} for:		
				d	L	d_f	$h_{nom,min}$	$h_{nom,std}$	$h_{nom,max}$
				[mm]	[mm]	[mm]	[mm]	[mm]	[mm]
M8	R-STUDS-08110	R-STUDS-08110-88	R-STUDS-08110-A4	8	110	9	40	20	-
	R-STUDS-08160	-	R-STUDS-08160-A4	8	160	9	90	70	50
M10	R-STUDS-10130	R-STUDS-10130-88	R-STUDS-10130-A4	10	130	12	48	28	-
	R-STUDS-10170	-	R-STUDS-10170-A4	10	170	12	88	68	38
	R-STUDS-10190	-	R-STUDS-10190-A4	10	190	12	108	88	58
M12	R-STUDS-12160	R-STUDS-12160-88	R-STUDS-12160-A4	12	160	14	65	35	-
	R-STUDS-12190	-	R-STUDS-12190-A4	12	190	14	95	65	30
	R-STUDS-12220	-	R-STUDS-12220-A4	12	220	14	125	95	60
	R-STUDS-12260	-	R-STUDS-12260-A4	12	260	14	165	135	100
M16	R-STUDS-12300	-	R-STUDS-12300-A4	12	300	14	205	175	140
	R-STUDS-16190	R-STUDS-16190-88	R-STUDS-16190-A4	16	190	18	71	46	-
	R-STUDS-16220	R-STUDS-16220-88	R-STUDS-16220-A4	16	220	18	101	76	11
	R-STUDS-16260	-	R-STUDS-16260-A4	16	260	18	141	116	51
	R-STUDS-16300	-	R-STUDS-16300-A4	16	300	18	181	156	91
M20	R-STUDS-16380	-	R-STUDS-16380-A4	16	380	18	261	236	171
	R-STUDS-20260	R-STUDS-20260-88	R-STUDS-20260-A4	20	260	22	117	67	-
	R-STUDS-20300	-	R-STUDS-20300-A4	20	300	22	157	107	37
M24	R-STUDS-20350	-	R-STUDS-20350-A4	20	350	22	207	157	87
	R-STUDS-24300	R-STUDS-24300-88	R-STUDS-24300-A4	24	300	26	132	62	-
M30	R-STUDS-30380	R-STUDS-30380-88	R-STUDS-30380-A4	30	380	32	181	106	-

* Make to order

Installation data

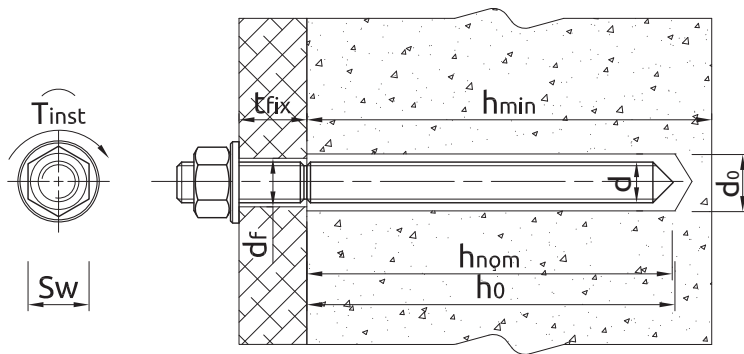

R-STUDS

Size			M8	M10	M12	M16	M20	M24	M30
Thread diameter	d	[mm]	8	10	12	16	20	24	30
Hole diameter in substrate	d ₀	[mm]	10	12	14	18	24	28	35
Hole diameter in fixture	d _f	[mm]	9	12	14	18	22	26	32
Min. hole depth in substrate	h ₀	[mm]	h _{nom} + 5	h _{nom} + 5	h _{nom} + 5	h _{nom} + 5	h _{nom} + 5	h _{nom} + 5	h _{nom} + 5
Min. substrate thickness	h _{min}	[mm]	h _{nom} + 30 ≥ 100	h _{nom} + 30 ≥ 100	h _{nom} + 30 ≥ 100	h _{nom} + 30 ≥ 100	h _{nom} + 2d ₀	h _{nom} + 2d ₀	h _{nom} + 2d ₀
Installation torque	T _{inst}	[Nm]	10	20	40	80	120	180	300
Min. spacing	s _{min}	[mm]	0.5 * h _{nom} ≥ 40	0.5 * h _{nom} ≥ 40	0.5 * h _{nom} ≥ 40	0.5 * h _{nom} ≥ 40	0.5 * h _{nom} ≥ 40	0.5 * h _{nom} ≥ 40	0.5 * h _{nom} ≥ 40
Min. edge distance	c _{min}	[mm]	0.5 * h _{nom} ≥ 40	0.5 * h _{nom} ≥ 40	0.5 * h _{nom} ≥ 40	0.5 * h _{nom} ≥ 40	0.5 * h _{nom} ≥ 40	0.5 * h _{nom} ≥ 40	0.5 * h _{nom} ≥ 40
MINIMUM EMBEDMENT DEPTH									
Installation depth	h _{nom, min}	[mm]	60	70	80	100	120	140	165
MAXIMUM EMBEDMENT DEPTH									
Installation depth	h _{nom, max}	[mm]	100	120	145	190	240	290	360

Minimum working and curing time

Resin temperature °C	Concrete temperature °C	Working time [min.]			Curing time* [min.]		
		R-KER-S	R-KER	R-KER-W	R-KER-S	R-KER	R-KER-W
5	-20	-	-	100	-	-	24 h
5	-15	-	-	60	-	-	16 h
5	-10	-	-	30	-	-	8 h
5	-5	65	60	16	24 h	6 h	4 h
5	0	50	40	12	16 h	3 h	2 h
5	5	35	20	8	12 h	2 h	1 h
10	10	20	12	5	8 h	80	45
15	15	12	8	3	6 h	60	30
20	20	9	5	2	4 h	45	10
25	25	7	3	-	3 h	30	-
25	30	6	2	-	2 h	20	-
25	40	4	0.5	-	45	10	-
25	45	3	-	-	35	-	-
25	50	2	-	-	25	-	-

*For wet concrete the curing time must be doubled

Mechanical properties

R-STUDS

Size			M8	M10	M12	M16	M20	M24	M30
R-STUDS METRIC THREADED RODS - steel class 5.8									
Nominal ultimate tensile strength - tension	f_{uk}	[N/mm ²]	500	500	500	500	500	500	500
Nominal yield strength - tension	f_{yk}	[N/mm ²]	400	400	400	400	400	400	400
Cross sectional area - tension	A_s	[mm ²]	36.6	58	84.3	157	245	352.8	559.8
Elastic section modulus	W_{el}	[mm ³]	31.2	62.3	109.2	277.5	541	935	1868
Characteristic bending resistance	$M^0_{Rk,s}$	[Nm]	19	37	65	166	324	561	1124
Design bending resistance	M	[Nm]	15	30	52	133	259	449	899
Allowable bending resistance	M_{rec}	[Nm]	11	21	37	95	185	321	642
R-STUDS METRIC THREADED RODS - steel class 8.8									
Nominal ultimate tensile strength - tension	f_{uk}	[N/mm ²]	800	800	800	800	800	800	800
Nominal yield strength - tension	f_{yk}	[N/mm ²]	640	640	640	640	640	640	640
Cross sectional area - tension	A_s	[mm ²]	36.6	58	84.3	157	245	352.8	559.8
Elastic section modulus	W_{el}	[mm ³]	31.2	62.3	109.2	277.5	541	935	1868
Characteristic bending resistance	$M^0_{Rk,s}$	[Nm]	30	60	105	266	519	898	1799
Design bending resistance	M	[Nm]	24	48	84	213	416	718	1439
Allowable bending resistance	M_{rec}	[Nm]	17	34	60	152	297	513	1028
R-STUDS METRIC THREADED RODS - A4									
Nominal ultimate tensile strength - tension	f_{uk}	[N/mm ²]	700	700	700	700	700	700	700
Nominal yield strength - tension	f_{yk}	[N/mm ²]	350	350	350	350	350	350	350
Cross sectional area - tension	A_s	[mm ²]	36.6	58	84.3	157	245	352.8	559.8
Elastic section modulus	W_{el}	[mm ³]	31.2	62.3	109.2	277.5	541	935	1868
Characteristic bending resistance	$M^0_{Rk,s}$	[Nm]	26	52	92	233	454	786	1574
Design bending resistance	M	[Nm]	17	34	59	149	291	504	1009
Allowable bending resistance	M_{rec}	[Nm]	12	24	42	107	208	360	721

Basic performance data

R-STUDS

Performance data for single anchor without influence of edge distance and spacing

Size		M8	M10	M12	M16	M20	M24	M30	M12	M16	M20	M24
CHARACTERISTIC LOAD												
TENSION LOAD N_{Rk}												
R-STUDS METRIC THREADED RODS - STEEL CLASS 5.8												
Minimum embedment depth	[kN]	18.0	28.6	36.1	50.5	66.4	83.7	107.0	19.6	22.6	30.2	42.2
Maximum embedment depth	[kN]	18.0	41.0	42.0	78.0	122.0	176.0	237.5	35.5	43.0	60.3	87.5
R-STUDS METRIC THREADED RODS - STEEL CLASS 8.8												
Minimum embedment depth	[kN]	19.6	28.6	36.1	50.5	66.4	83.7	107.0	19.6	22.6	30.2	42.2
Maximum embedment depth	[kN]	29.0	46.0	67.0	105.1	143.3	196.8	237.5	35.5	43.0	60.3	87.5
R-STUDS METRIC THREADED RODS - A4												
Minimum embedment depth	[kN]	19.6	28.6	36.1	50.5	66.4	83.7	107.0	19.6	22.6	30.2	42.2
Maximum embedment depth	[kN]	26.0	41.0	59.0	105.1	143.3	196.8	237.5	35.5	43.0	60.3	87.5
SHEAR LOAD V_{Rk}												
R-STUDS METRIC THREADED RODS - STEEL CLASS 5.8												
Minimum embedment depth	[kN]	9.00	20.0	21.0	39.0	61.0	88.0	140.0	21.0	39.0	60.3	84.5
Maximum embedment depth	[kN]	9.00	20.0	21.0	39.0	61.0	88.0	140.0	21.0	39.0	61.0	88.0
R-STUDS METRIC THREADED RODS - STEEL CLASS 8.8												
Minimum embedment depth	[kN]	15.0	23.0	34.0	63.0	98.0	141.0	214.1	34.0	45.2	60.3	84.5
Maximum embedment depth	[kN]	15.0	23.0	34.0	63.0	98.0	141.0	224.0	34.0	63.0	98.0	141.0
R-STUDS METRIC THREADED RODS - A4												
Minimum embedment depth	[kN]	13.0	20.0	29.0	55.0	86.0	124.0	196.0	29.0	45.2	60.3	84.5
Maximum embedment depth	[kN]	13.0	20.0	29.0	55.0	86.0	124.0	196.0	29.0	55.0	86.0	124.0

Basic performance data (cont.)

R-STUDS

Performance data for single anchor without influence of edge distance and spacing

Size		M8	M10	M12	M16	M20	M24	M30	M12	M16	M20	M24
DESIGN LOAD												
TENSION LOAD N_{Rd}												
R-STUDS METRIC THREADED RODS - STEEL CLASS 5.8												
Minimum embedment depth	[kN]	10.9	15.9	20.1	28.1	36.9	39.8	51.0	10.9	12.6	16.8	20.1
Maximum embedment depth	[kN]	12.0	21.9	28.0	52.0	79.6	93.7	113.1	19.7	23.9	33.5	41.7
R-STUDS METRIC THREADED RODS - STEEL CLASS 8.8												
Minimum embedment depth	[kN]	10.9	15.9	20.1	28.1	36.9	39.8	51.0	10.9	12.6	16.8	20.1
Maximum embedment depth	[kN]	18.2	27.2	39.5	58.4	79.6	93.7	113.1	19.7	23.9	33.5	41.7
R-STUDS METRIC THREADED RODS - A4												
Minimum embedment depth	[kN]	10.9	15.9	20.1	28.1	36.9	39.8	51.0	10.9	12.6	16.8	20.1
Maximum embedment depth	[kN]	13.9	21.9	31.6	58.4	79.6	93.7	113.1	19.7	23.9	33.5	41.7
SHEAR LOAD V_{Rd}												
R-STUDS METRIC THREADED RODS - STEEL CLASS 5.8												
Minimum embedment depth	[kN]	7.20	12.8	16.8	31.2	48.8	70.4	112.0	16.8	30.2	40.2	56.3
Maximum embedment depth	[kN]	7.20	12.8	16.8	31.2	48.8	70.4	112.0	16.8	31.2	48.8	70.4
R-STUDS METRIC THREADED RODS - STEEL CLASS 8.8												
Minimum embedment depth	[kN]	12.0	18.4	27.2	50.4	78.4	111.5	142.7	26.1	30.2	40.2	56.3
Maximum embedment depth	[kN]	12.0	18.4	27.2	50.4	78.4	112.8	179.2	27.2	50.4	78.4	112.8
R-STUDS METRIC THREADED RODS - A4												
Minimum embedment depth	[kN]	8.33	12.8	18.6	35.3	55.1	79.5	125.6	18.6	30.2	40.2	56.3
Maximum embedment depth	[kN]	8.33	12.8	18.6	35.3	55.1	79.5	125.6	18.6	35.3	55.1	79.5
RECOMMENDED LOAD												
TENSION LOAD N_{rec}												
R-STUDS METRIC THREADED RODS - STEEL CLASS 5.8												
Minimum embedment depth	[kN]	7.78	11.3	14.3	20.0	26.3	28.5	36.4	7.78	8.98	12.0	14.4
Maximum embedment depth	[kN]	8.57	15.7	20.0	37.1	56.9	66.9	80.8	14.1	17.1	23.9	29.8
R-STUDS METRIC THREADED RODS - STEEL CLASS 8.8												
Minimum embedment depth	[kN]	7.78	11.3	14.3	20.0	26.3	28.5	36.4	7.78	8.98	12.0	14.4
Maximum embedment depth	[kN]	13.0	19.5	28.2	41.7	56.9	66.9	80.8	14.1	17.1	23.9	29.8
R-STUDS METRIC THREADED RODS - A4												
Minimum embedment depth	[kN]	7.78	11.3	14.3	20.0	26.3	28.5	36.4	7.78	8.98	12.0	14.4
Maximum embedment depth	[kN]	9.93	15.7	22.5	41.7	56.9	66.9	80.8	14.1	17.1	23.9	29.8
SHEAR LOAD V_{rec}												
R-STUDS METRIC THREADED RODS - STEEL CLASS 5.8												
Minimum embedment depth	[kN]	5.14	9.16	12.0	22.3	34.9	50.3	80.0	12.0	21.5	28.7	40.2
Maximum embedment depth	[kN]	5.14	9.16	12.0	22.3	34.9	50.3	80.0	12.0	22.3	34.9	50.3
R-STUDS METRIC THREADED RODS - STEEL CLASS 8.8												
Minimum embedment depth	[kN]	8.57	13.1	19.4	36.0	56.0	79.7	101.9	18.7	21.5	28.7	40.2
Maximum embedment depth	[kN]	8.57	13.1	19.4	36.0	56.0	80.6	128.0	19.4	36.0	56.0	80.6
R-STUDS METRIC THREADED RODS - A4												
Minimum embedment depth	[kN]	5.95	9.16	13.3	25.2	39.4	56.8	89.7	13.3	21.5	28.7	40.2
Maximum embedment depth	[kN]	5.95	9.16	13.3	25.2	39.4	56.8	89.7	13.3	25.2	39.4	56.8

Product commercial data

Product Code	Volume [m]	Quantity [pcs]			Weight [kg]			Bar Codes
		Box	Outer	Pallet	Box	Outer	Pallet	
R-KER-300	300	10	10	840	6.3	6.3	559.2	5906675075167
R-KER-345	345	10	10	840	7.1	7.1	623.3	5906675291086
R-KER-380	380	10	10	560	8.2	8.2	486.6	5906675222707
R-KER-400	400	10	10	560	8.1	8.1	483.8	5906675329444
R-KER-300-W	300	10	10	840	6.3	6.3	559.2	5906675432021
R-KER-380-W	380	10	10	560	8.2	8.2	486.6	5906675222981
R-KER-400-W	400	10	10	560	8.2	8.2	489.2	5906675380445
R-KER-380-S	380	10	10	560	6.5	6.5	391.2	5906675099088
R-KER-400-S	400	10	10	560	8.2	8.2	489.2	5906675380452

R-KER with Sockets

High performance vinylester resin approved for use with internally threaded sockets



Approvals and Reports

- ETA-13/0805



Product overview

Features and benefits

- Approved for use with sockets in non-cracked concrete
- Allows removal of bolt to leave a re-usable socket in place
- Suitable for use in low temperatures (down to -20° C for winter option) enables use throughout the year
- Winter version can be used in warmer temperatures for faster curing
- Suitable for use in dry and wet substrates as well as holes and substrates covered with water
- Rapid bonding time enables quick execution of works
- Very high load capacity
- Anchor does not generate tensions in the substrate which enables R-KER to be specified where closer edge and spacing distances are required
- Suitable for multiple use. Partly used cartridge can continue to be used after fitting new nozzle

Applications

- Temporary works/formworks support systems
- Balustrading
- Cladding restrains
- Masonry support
- Machinery
- Platforms
- Steelwork

Base materials

- Approved for use in:
- Non-cracked concrete C20/25-C50/60

Installation guide

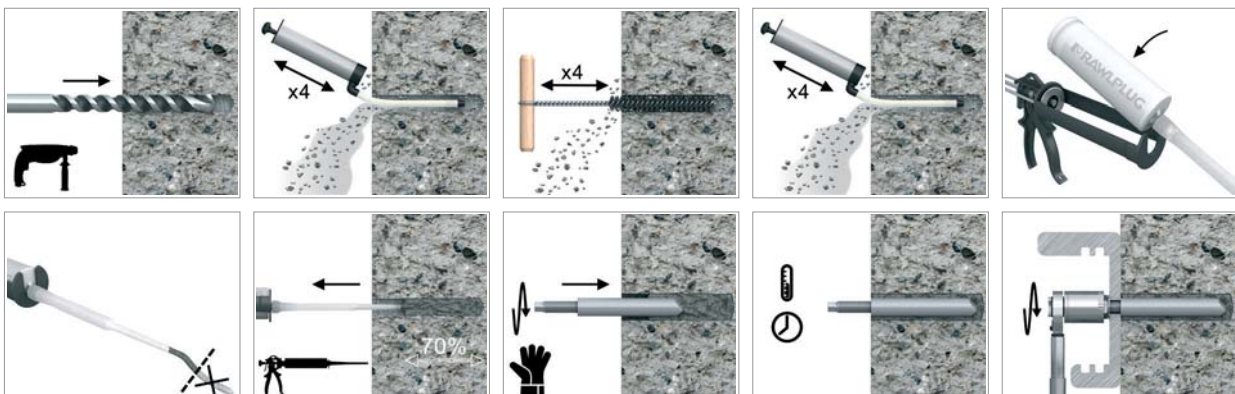

Installation guide (cont.)

1. Drill hole to the required diameter and depth for socket size being used.
2. Clean the drill hole thoroughly with brush and hand pump at least four times before installation.
3. Attach nozzle and insert cartridge into gun.
4. Dispense to waste until even colour is obtained.
5. Insert the mixer nozzle to the bottom of the drill hole and inject resin, slowly withdrawing the nozzle as the hole is filled to 70% of its depth.
6. Immediately insert the socket, slowly and with slight twisting motion. Remove any excess resin around the hole before it sets and leave it undisturbed until the curing time elapses.
7. Attach fixture and tighten the bolt to the required torque.

Product information

Product Code	Resin	Description / Resin Type	Volume
			[ml]
R-KER-300	R-KER	Styrene Free Vinylester Resin	300
R-KER-345			345
R-KER-380			380
R-KER-400			400
R-KER-300-W	R-KER-W	Low Temperature (Winter) / Rapid Cure Styrene Free Vinylester Resin	300
R-KER-380-W			380
R-KER-400-W			400
R-KER-380-S	R-KER-S	High Temperature (Summer) / Slow Cure Styrene Free Vinylester Resin	380
R-KER-400-S			400

SOCKETS

Size	Product Code		Anchor			Fixture
	Steel class 5.8	Steel grade A4	Socket diameter	Length	Internal thread length	Hole diameter
			d	L	l_g	d_f
			[mm]	[mm]	[mm]	[mm]
M6	R-ITS-Z-06075	R-ITS-A4-06075	10	75	24	7
M8	R-ITS-Z-08075	R-ITS-A4-08075	12	75	25	9
	R-ITS-Z-08090	R-ITS-A4-08090	12	90	25	9
M10	R-ITS-Z-10075	R-ITS-A4-10075	16	75	30	12
	R-ITS-Z-10100	R-ITS-A4-10100	16	100	30	12
M12	R-ITS-Z-12100	R-ITS-A4-12100	16	100	35	14
M16	R-ITS-Z-16125	R-ITS-A4-16125	24	125	50	18

Installation data

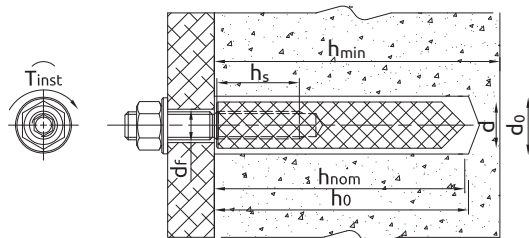

Size			M6	M8		M10		M12	M16
Installation depth	h_{nom}	[mm]	75	75	90	75	100	100	125
Thread diameter	d	[mm]	6	8	8	10	10	12	16
Hole diameter in substrate	d_0	[mm]	12	14	14	20	20	20	28
Hole diameter in fixture	d_f	[mm]	7	9	9	12	12	14	18
Thread engagement length; min - max	h_s	[mm]	24	25	25	30	30	35	50
Min. hole depth in substrate	h_0	[mm]	$h_{nom} + 5$	$h_{nom} + 5$	$h_{nom} + 5$	$h_{nom} + 5$	$h_{nom} + 5$	$h_{nom} + 5$	$h_{nom} + 5$
Min. substrate thickness	h_{min}	[mm]	105	105	120	115	140	140	181
Installation torque	T_{inst}	[Nm]	3	5	5	10	10	20	40
Min. spacing	s_{min}	[mm]	40	40	45	40	50	50	63
Min. edge distance	c_{min}	[mm]	40	40	45	40	50	50	63

Installation data

Minimum working and curing time

Resin temperature °C	Concrete temperature °C	Working time [min.]			Curing time* [min.]		
		R-KER-S	R-KER	R-KER-W	R-KER-S	R-KER	R-KER-W
5	-20	-	-	100	-	-	24h
5	-15	-	-	60	-	-	16h
5	-10	-	-	30	-	-	8h
5	-5	65	60	16	24h	6h	4h
5	0	50	40	12	16h	3h	2h
5	5	35	20	8	12h	2h	1h
10	10	20	12	5	8h	80	45
15	15	12	8	3	6h	60	30
20	20	9	5	2	4h	45	10
25	25	7	3	-	3h	30	-
25	30	6	2	-	2h	20	-
25	40	5	0.5	-	45	10	-
25	45	3	-	-	35	-	-
25	50	2	-	-	25	-	-

*For wet concrete the curing time must be doubled

Mechanical properties

SOCKETS

Size			M6	M8	M10	M12	M16
R-ITS-A4 INTERNALLY THREADED SOCKETS							
Nominal ultimate tensile strength - tension	f_{uk}	[N/mm ²]	700	700	700	700	700
Nominal yield strength - tension	f_{yk}	[N/mm ²]	350	350	350	350	350
Cross sectional area - tension	A_s	[mm ²]	20.1	36.6	58	84.3	157
Elastic section modulus	W_{el}	[mm ³]	21.21	50.27	98.17	169.65	402.12
R-ITS-Z INTERNALLY THREADED SOCKETS							
Nominal ultimate tensile strength - tension	f_{uk}	[N/mm ²]	520	500	500	500	500
Nominal yield strength - tension	f_{yk}	[N/mm ²]	420	400	400	400	400
Cross sectional area - tension	A_s	[mm ²]	20.1	36.6	58	84.3	157
Elastic section modulus	W_{el}	[mm ³]	21.21	50.27	98.17	169.65	402.12
R-STUDS METRIC THREADED RODS - steel class 5.8							
Characteristic bending resistance	$M_{Rk,s}^0$	[Nm]	8	19	37	65	166
Design bending resistance	M	[Nm]	6	15	30	52	133
Allowable bending resistance	M_{rec}	[Nm]	5	11	21	37	95
R-STUDS METRIC THREADED RODS - steel class 8.8							
Characteristic bending resistance	$M_{Rk,s}^0$	[Nm]	12	30	60	105	266
Design bending resistance	M	[Nm]	10	24	48	84	213
Allowable bending resistance	M_{rec}	[Nm]	7	17	34	60	152
R-STUDS METRIC THREADED RODS - A4							
Characteristic bending resistance	$M_{Rk,s}^0$	[Nm]	11	26	52	92	233
Design bending resistance	M	[Nm]	7	17	34	59	149
Allowable bending resistance	M_{rec}	[Nm]	5	12	24	42	107

Basic performance data

SOCKETS

Performance data for single anchor without influence of edge distance and spacing

Size		M6	M8	M10	M12	M16		
Substrate		Non-cracked concrete						
Embedment depth h_{nom}	[mm]	75	90	75	100	125		
CHARACTERISTIC LOAD								
TENSION LOAD N_{Rk}								
R-STUDS METRIC THREADED RODS - STEEL CLASS 5.8	[kN]	10.0	18.0	18.0	29.0	29.0	42.0	66.0
R-STUDS METRIC THREADED RODS - STEEL CLASS 8.8	[kN]	16.0	25.4	29.0	32.8	46.0	42.7	66.0
R-STUDS METRIC THREADED RODS - A4	[kN]	14.0	25.4	26.0	32.8	41.0	42.7	66.0
SHEAR LOAD V_{Rk}								
R-STUDS METRIC THREADED RODS - STEEL CLASS 5.8	[kN]	5.0	9.0	9.0	14.0	14.0	21.0	39.0
R-STUDS METRIC THREADED RODS - STEEL CLASS 8.8	[kN]	8.0	15.0	15.0	23.0	23.0	34.0	63.0
R-STUDS METRIC THREADED RODS - A4	[kN]	7.0	13.0	13.0	20.0	20.0	29.0	55.0
DESIGN LOAD								
TENSION LOAD N_{Rd}								
R-STUDS METRIC THREADED RODS - STEEL CLASS 5.8	[kN]	6.7	12.0	12.0	18.2	19.3	23.7	36.7
R-STUDS METRIC THREADED RODS - STEEL CLASS 8.8	[kN]	9.82	14.1	17.0	18.2	26.5	23.7	36.7
R-STUDS METRIC THREADED RODS - A4	[kN]	7.49	13.9	13.9	18.2	21.9	23.7	36.7
SHEAR LOAD V_{Rd}								
R-STUDS METRIC THREADED RODS - STEEL CLASS 5.8	[kN]	4.0	7.2	7.2	11.2	11.2	16.8	31.2
R-STUDS METRIC THREADED RODS - STEEL CLASS 8.8	[kN]	6.4	12.0	12.0	18.4	18.4	27.2	50.4
R-STUDS METRIC THREADED RODS - A4	[kN]	4.49	8.33	8.33	12.8	12.8	18.6	35.3
RECOMMENDED LOAD								
TENSION LOAD N_{rec}								
R-STUDS METRIC THREADED RODS - STEEL CLASS 5.8	[kN]	4.79	8.57	8.57	13.0	13.8	16.9	26.2
R-STUDS METRIC THREADED RODS - STEEL CLASS 8.8	[kN]	7.01	10.1	12.1	13.0	18.9	16.9	26.2
R-STUDS METRIC THREADED RODS - A4	[kN]	5.35	9.93	9.93	13.0	15.6	16.9	26.2
SHEAR LOAD V_{rec}								
R-STUDS METRIC THREADED RODS - STEEL CLASS 5.8	[kN]	2.86	5.14	5.14	8.0	8.0	12.0	22.3
R-STUDS METRIC THREADED RODS - STEEL CLASS 8.8	[kN]	4.57	8.57	8.57	13.1	13.1	19.4	36.0
R-STUDS METRIC THREADED RODS - A4	[kN]	3.21	5.95	5.95	9.16	9.16	13.3	25.2

Product commercial data

Product Code	Volume [m]	Quantity [pcs]			Weight [kg]			Bar Codes
		Box	Outer	Pallet	Box	Outer	Pallet	
R-KER-300	300	10	10	840	6.3	6.3	559.2	5906675075167
R-KER-345	345	10	10	840	7.1	7.1	623.3	5906675291086
R-KER-400	400	10	10	560	8.1	8.1	483.8	5906675329444
R-KER-300-W	300	10	10	840	6.3	6.3	559.2	5906675432021
R-KER-380-W	380	10	10	560	8.2	8.2	486.6	5906675222981
R-KER-400-S	400	10	10	560	8.2	8.2	489.2	5906675380452

R-KER with Rebar as an Anchor

High performance vinylester resin approved for use with reinforcement bars



Installation movie



Approvals and Reports

- ETA-13/0805



Product overview

Features and benefits

- Approved for use with rebar as an anchor in non-cracked concrete
- Suitable for use in low temperatures (down to -20° C for winter option) enables use throughout the year
- Winter version can be used in warmer temperatures for faster curing
- Suitable for use in dry and wet substrates as well as holes and substrates covered with water
- Rapid bonding time enables quick execution of works
- Very high load capacity
- Anchor does not generate tensions in the substrate which enables R-KER to be specified where closer edge and spacing distances are required
- Suitable for multiple use. Partly used cartridge can continue to be used after fitting new nozzle

Applications

- Curtain walling
- Balustrading
- Barriers
- Cable trays
- Cladding restraints
- Steelwork
- Rebar dowelling
- Starter bars
- Rebar missed-outs

Base materials

Approved for use in:

- Non-cracked concrete C20/25-C50/60

Installation guide

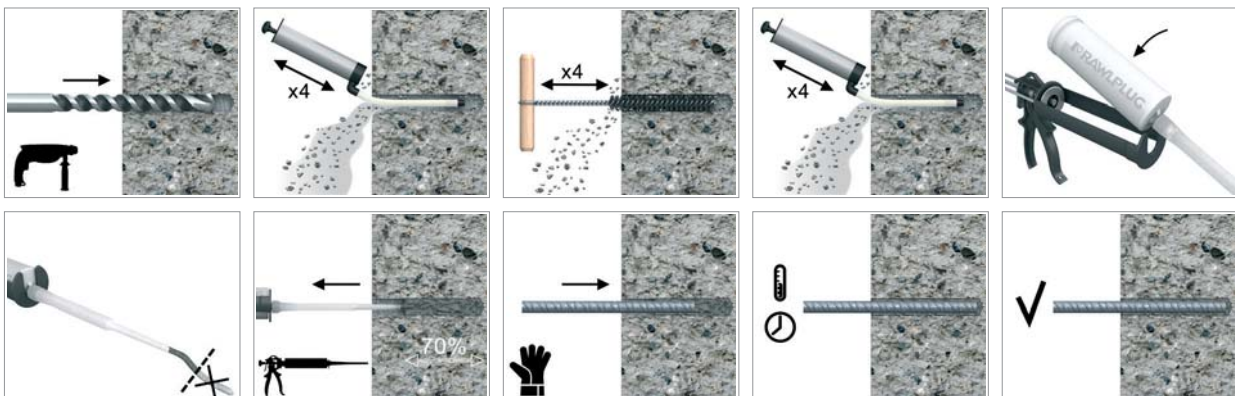

Installation guide (cont.)

1. Drill hole to the required diameter and depth for rebar size being used.
2. Clean the drill hole thoroughly with brush and hand pump at least four times before installation.
3. Attach nozzle and insert cartridge into gun.
4. Dispense to waste until even colour is obtained.
5. Insert the mixer nozzle to the bottom of the drill hole and inject resin, slowly withdrawing the nozzle as the hole is filled to 70% of its depth.
6. Immediately insert the rebar, slowly and with slight twisting motion. Remove any access resin around the hole before it sets and leave it undisturbed until the curing time elapses.

Product information

Product Code	Resin	Description / Resin Type	Volume
			[ml]
R-KER-300	R-KER	Styrene Free Vinylester Resin	300
R-KER-345			345
R-KER-400			400
R-KER-300-W	R-KER-W	Low Temperature (Winter) / Rapid Cure Styrene Free Vinylester Resin	300
R-KER-380-W			380
R-KER-400-S	R-KER-S	High Temperature (Summer) / Slow Cure Styrene Free Vinylester Resin	400

Installation data

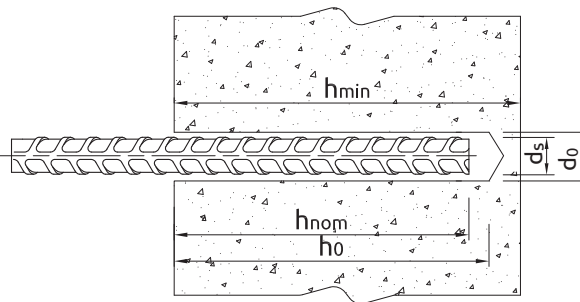

REBARS AS ANCHORS

Size			Ø8	Ø10	Ø12	Ø14	Ø16	Ø20	Ø25	Ø32
Rebar diameter	d_s	[mm]	8	10	12	14	16	20	25	32
Hole diameter in substrate	d_0	[mm]	12	14	18	18	22	26	32	40
Min. hole depth in substrate	h_0	[mm]	$h_{nom}+5$	$h_{nom}+5$	$h_{nom}+5$	$h_{nom}+5$	$h_{nom}+5$	$h_{nom}+5$	$h_{nom}+5$	$h_{nom}+5$
Min. substrate thickness	h_{min}	[mm]	$h_{nom}+30$ ≥ 100	$h_{nom}+30$ ≥ 100	$h_{nom}+2d_0$	$h_{nom}+2d_0$	$h_{nom}+2d_0$	$h_{nom}+2d_0$	$h_{nom}+2d_0$	$h_{nom}+2d_0$
Min. spacing	s_{min}	[mm]	$0.5 * h_{nom} \geq 40$	$0.5 * h_{nom} \geq 40$	$0.5 * h_{nom} \geq 40$	$0.5 * h_{nom} \geq 40$	$0.5 * h_{nom} \geq 40$	$0.5 * h_{nom} \geq 40$	$0.5 * h_{nom} \geq 40$	$0.5 * h_{nom} \geq 40$
Min. edge distance	c_{min}	[mm]	$0.5 * h_{nom} \geq 40$	$0.5 * h_{nom} \geq 40$	$0.5 * h_{nom} \geq 40$	$0.5 * h_{nom} \geq 40$	$0.5 * h_{nom} \geq 40$	$0.5 * h_{nom} \geq 40$	$0.5 * h_{nom} \geq 40$	$0.5 * h_{nom} \geq 40$
MINIMUM EMBEDMENT DEPTH										
Installation depth	$h_{nom,min}$	[mm]	60	70	80	80	100	120	140	165
MAXIMUM EMBEDMENT DEPTH										
Installation depth	$h_{nom,max}$	[mm]	100	120	145	145	190	240	290	360

Installation data (cont.)

Minimum working and curing time

Resin temperature °C	Concrete temperature °C	Working time [min.]			Curing time* [min.]		
		R-KER-S	R-KER	R-KER-W	R-KER-S	R-KER	R-KER-W
5	-20	-	-	100	-	-	24h
5	-15	-	-	60	-	-	16h
5	-10	-	-	30	-	-	8h
5	-5	65	60	16	24h	6h	4h
5	0	50	40	12	16h	3h	2h
5	5	35	20	8	12h	2h	1h
10	10	20	12	5	8h	80	45
15	15	12	8	3	6h	60	30
20	20	9	5	2	4h	45	10
25	25	7	3	-	3h	30	-
25	30	6	2	-	2h	20	-
25	40	5	0.5	-	45	10	-
25	45	3	-	-	35	-	-
25	50	2	-	-	25	-	-

*For wet concrete the curing time must be doubled

Mechanical properties

REBARS AS ANCHORS

Size			Ø8	Ø10	Ø12	Ø14	Ø16	Ø20	Ø25	Ø32
f_{uk} = 540 (e.g. 500 B acc. to BS 4449; B 500 B acc. to SS 560)										
Nominal ultimate tensile strength - tension	f _{uk}	[N/mm ²]	540	540	540	540	540	540	540	540
Nominal yield strength - tension	f _{yk}	[N/mm ²]	500	500	500	500	500	500	500	500
Cross sectional area - tension	A _s	[mm ²]	50.3	78.5	113.1	153.9	201.1	314.2	490.9	804.2
Elastic section modulus	W _{el}	[mm ³]	50.3	98.2	169.6	269.4	402.1	785.4	1534	3217
f_{uk} = 575 (e.g. B 500 SP acc. to EC2)										
Nominal ultimate tensile strength - tension	f _{uk}	[N/mm ²]	575	575	575	575	575	575	575	575
Nominal yield strength - tension	f _{yk}	[N/mm ²]	500	500	500	500	500	500	500	500
Cross sectional area - tension	A _s	[mm ²]	50.3	78.5	113.1	153.9	201.1	314.2	490.9	804.2
Elastic section modulus	W _{el}	[mm ³]	50.3	98.2	169.6	269.4	402.1	785.4	1534	3217
f_{uk} = 620 (e.g. G-60 acc. to ASTM 615)										
Nominal ultimate tensile strength - tension	f _{uk}	[N/mm ²]	620	620	620	620	620	620	620	620
Nominal yield strength - tension	f _{yk}	[N/mm ²]	420	420	420	420	420	420	420	420
Cross sectional area - tension	A _s	[mm ²]	50.3	78.5	113.1	153.9	201.1	314.2	490.9	804.2
Elastic section modulus	W _{el}	[mm ³]	50.3	98.2	169.6	269.4	402.1	785.4	1534	3217

Basic performance data

REBARS AS ANCHORS

Size		Ø8	Ø10	Ø12	Ø14	Ø16	Ø20	Ø25	Ø32
Substrate		Non-cracked concrete							
CHARACTERISTIC LOAD									
TENSION LOAD N_{rk}									
fuk = 540 (e.g. 500 B acc. to BS 4449; B 500 B acc. to SS 560)									
Minimum embedment depth	[kN]	16.6	22.0	30.2	31.7	45.3	56.6	77.0	107.0
Maximum embedment depth	[kN]	27.1	37.7	54.7	57.4	86.0	113.1	159.4	235.2
fuk = 575 (e.g. B 500 SP acc. to EC2)									
Minimum embedment depth	[kN]	16.6	22.0	30.2	31.7	45.2	56.6	77.0	107.0
Maximum embedment depth	[kN]	27.7	37.7	54.7	57.4	86.0	113.1	159.4	235.2
fuk = 620 (e.g. G-60 acc. to ASTM 615)									
Minimum embedment depth	[kN]	16.6	22.0	30.2	31.7	45.2	56.6	77.0	107.0
Maximum embedment depth	[kN]	27.7	37.7	54.7	57.4	86.0	113.1	159.4	235.2
SHEAR LOAD V_{rk}									
fuk = 540 (e.g. 500 B acc. to BS 4449; B 500 B acc. to SS 560)									
Minimum embedment depth	[kN]	13.6	21.2	30.5	41.6	54.3	84.8	132.5	214.1
Maximum embedment depth	[kN]	13.6	21.2	30.5	41.6	54.3	84.8	132.5	217.2
fuk = 575 (e.g. B 500 SP acc. to EC2)									
Minimum embedment depth	[kN]	14.5	22.6	32.5	44.3	57.8	90.3	141.1	214.1
Maximum embedment depth	[kN]	14.5	22.6	32.5	44.3	57.8	90.3	141.1	231.2
fuk = 620 (e.g. G-60 acc. to ASTM 615)									
Minimum embedment depth	[kN]	15.6	24.4	35.1	47.7	62.3	97.4	152.2	214.1
Maximum embedment depth	[kN]	15.6	24.4	35.1	47.7	62.3	97.4	152.2	249.3
DESIGN LOAD									
TENSION LOAD N_{Rd}									
fuk = 540 (e.g. 500 B acc. to BS 4449; B 500 B acc. to SS 560)									
Minimum embedment depth	[kN]	9.22	12.2	16.8	17.6	25.1	31.4	42.8	59.5
Maximum embedment depth	[kN]	15.4	20.9	30.4	31.9	47.8	62.8	88.6	130.7
fuk = 575 (e.g. B 500 SP acc. to EC2)									
Minimum embedment depth	[kN]	9.22	12.2	16.8	17.6	25.1	31.4	42.8	59.5
Maximum embedment depth	[kN]	15.4	20.9	30.4	31.9	47.8	62.8	88.6	130.7
fuk = 620 (e.g. G-60 acc. to ASTM 615)									
Minimum embedment depth	[kN]	9.22	12.2	16.8	17.6	25.1	31.4	42.8	59.5
Maximum embedment depth	[kN]	15.4	20.9	30.4	31.9	47.8	62.8	88.6	130.7
SHEAR LOAD V_{Rd}									
fuk = 540 (e.g. 500 B acc. to BS 4449; B 500 B acc. to SS 560)									
Minimum embedment depth	[kN]	9.05	14.1	20.4	27.7	36.2	56.6	88.4	142.7
Maximum embedment depth	[kN]	9.05	14.1	20.4	27.7	36.2	56.6	88.4	144.8
fuk = 575 (e.g. B 500 SP acc. to EC2)									
Minimum embedment depth	[kN]	9.63	15.1	21.7	29.5	38.5	60.2	94.1	142.7
Maximum embedment depth	[kN]	9.63	15.1	21.7	29.5	38.5	60.2	94.1	154.2
fuk = 620 (e.g. G-60 acc. to ASTM 615)									
Minimum embedment depth	[kN]	10.4	16.2	23.4	31.8	41.6	64.9	101.5	142.7
Maximum embedment depth	[kN]	10.4	16.2	23.4	31.8	41.6	64.9	101.5	166.2

Basic performance data (cont.)

REBARS AS ANCHORS

Size		Ø8	Ø10	Ø12	Ø14	Ø16	Ø20	Ø25	Ø32
RECOMMENDED LOAD									
TENSION LOAD N_{rec}									
fuk = 540 (e.g. 500 B acc. to BS 4449; B 500 B acc. to SS 560)									
Minimum embedment depth	[kN]	6.58	8.73	12.0	12.6	18.0	22.4	30.5	42.3
Maximum embedment depth	[kN]	11.0	15.0	21.7	22.8	34.1	44.9	63.3	93.4
fuk = 575 (e.g. B 500 SP acc. to EC2)									
Minimum embedment depth	[kN]	6.58	8.73	12.0	12.6	18.0	22.4	30.5	42.5
Maximum embedment depth	[kN]	11.0	15.0	21.7	22.8	34.1	44.9	63.3	93.4
fuk = 620 (e.g. G-60 acc. to ASTM 615)									
Minimum embedment depth	[kN]	6.58	8.73	12.0	12.6	18.0	22.4	30.5	42.5
Maximum embedment depth	[kN]	11.0	15.0	21.7	22.8	34.1	44.9	63.3	93.6
SHEAR LOAD V_{rec}									
fuk = 540 (e.g. 500 B acc. to BS 4449; B 500 B acc. to SS 560)									
Minimum embedment depth	[kN]	6.46	10.1	14.5	19.8	25.9	40.4	63.1	101.9
Maximum embedment depth	[kN]	6.46	10.1	14.5	19.8	25.9	40.4	63.1	103.4
fuk = 575 (e.g. B 500 SP acc. to EC2)									
Minimum embedment depth	[kN]	6.88	10.8	15.5	21.1	27.5	43.0	67.2	101.9
Maximum embedment depth	[kN]	6.88	10.8	15.5	21.1	27.5	43.0	67.2	110.1
fuk = 620 (e.g. G-60 acc. to ASTM 615)									
Minimum embedment depth	[kN]	7.42	11.6	16.7	22.7	29.7	46.4	72.5	101.9
Maximum embedment depth	[kN]	7.42	11.6	16.7	22.7	29.7	46.4	72.5	118.7

Product commercial data

Product Code	Volume [ml]	Quantity [pcs]			Weight [kg]			Bar Codes
		Box	Outer	Pallet	Box	Outer	Pallet	
R-KER-300	300	10	10	840	6.3	6.3	559.2	5906675075167
R-KER-345	345	10	10	840	7.1	7.1	623.3	5906675291086
R-KER-400	400	10	10	560	8.1	8.1	483.8	5906675329444
R-KER-300-W	300	10	10	840	6.3	6.3	559.2	5906675432021
R-KER-380-W	380	10	10	560	8.2	8.2	486.6	5906675222981
R-KER-400-S	400	10	10	560	8.2	8.2	489.2	5906675380452

R-KER with Post-Installed Rebar

High performance vinylester resin approved for use with post-installed rebar connections



Installation movie



Approvals and Reports

- ETA-12/0319



Product overview

Features and benefits

- Approved for use with post-installed rebars in non-cracked concrete
- Suitable for use in low temperatures (down to -20°C for winter option) enables use throughout the year
- Winter version can be used in warmer temperatures for faster curing
- Suitable for use in dry and wet substrates as well as holes and substrates covered with water
- Rapid bonding time enables quick execution of works
- Very high load capacity

Applications

- Post-installed rebar connections
- Rebar
- Temporary works/formworks support systems
- Safety barriers
- Barriers
- Platforms
- Rebar dowelling
- Starter bars
- Rebar missed-outs

Base materials

Approved for use in:

- Concrete C12/C15-C50/60

Installation guide

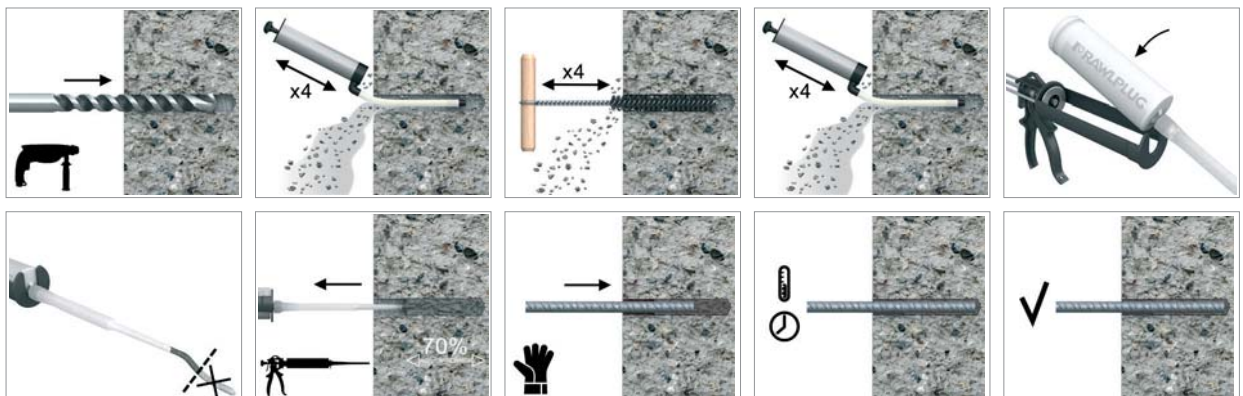

Installation guide (cont.)

1. Drill hole to the required diameter and depth for rebar size being used.
2. Clean the drill hole thoroughly with brush and hand pump at least four times before installation.
3. Attach nozzle and insert cartridge into gun.
4. Dispense to waste until even colour is obtained.
5. Insert the mixer nozzle to the bottom of the drill hole and inject resin, slowly withdrawing the nozzle as the hole is filled to 70% of its depth.
6. Immediately insert the rebar, slowly and with slight twisting motion. Remove any excess resin around the hole before it sets and leave it undisturbed until the curing time elapses. Attach fixture and tighten the nut to the required torque.

Product information

Product Code	Resin	Description / Resin Type	Volume
			[ml]
R-KER-300	R-KER	Styrene Free Vinylester Resin	300
R-KER-345			345
R-KER-400			400
R-KER-300-W	R-KER-W	Low Temperature (Winter) / Rapid Cure Styrene Free Vinylester Resin	300
R-KER-380-W			380
R-KER-400-S	R-KER-S	High Temperature (Summer) / Slow Cure Styrene Free Vinylester Resin	400

Installation data

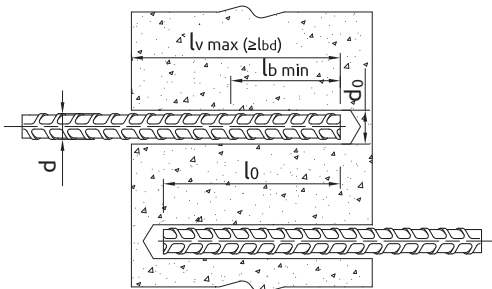

POST-INSTALLED REBARS

Size		Ø8	Ø10	Ø12	Ø14	Ø16	Ø20	Ø25	Ø28	Ø32
Rebar diameter	d_s [mm]	8	10	12	14	16	20	25	28	32
Hole diameter in substrate	d_0 [mm]	12	14	16	18	20	25	30	35	40
Brush diameter	- [mm]	14	16	18	20	22	27	32	37	42
Min. anchorage length	$l_{b, min.}$ [mm]	115	145	170	200	230	285	355	400	455
Min. lap length (overlap splice)	$l_{0, min.}$ [mm]	200	200	200	210	240	300	375	420	480
Max. anchorage length	$l_{v, max.}$ [mm]	400	500	600	700	800	1000	1000	1000	1000

Minimum working and curing time

Resin temperature °C	Concrete temperature °C	Working time [min.]			Curing time* [min.]		
		R-KER-S	R-KER	R-KER-W	R-KER-S	R-KER	R-KER-W
5	-20	-	-	100	-	-	24h
5	-15	-	-	60	-	-	16h
5	-10	-	-	30	-	-	8h
5	-5	65	60	16	24h	6h	4h
5	0	50	40	12	16h	3h	2h
5	5	35	20	8	12h	2h	1h
10	10	20	12	5	8h	80	45
15	15	12	8	3	6h	60	30
20	20	9	5	2	4h	45	10
25	25	7	3	-	3h	30	-
25	30	6	2	-	2h	20	-
25	40	5	0.5	-	45	10	-
25	45	3	-	-	35	-	-
25	50	2	-	-	25	-	-

*For wet concrete the curing time must be doubled

All products listed in this publication are branded and distributed with RAWLPLUG® or RAWL® trademarks.

Mechanical properties

POST INSTALLED REBARS

Size			Ø8	Ø10	Ø12	Ø14	Ø16	Ø20	Ø25	Ø28	Ø30	Ø32
fyk = 410 (e.g. 34GS acc. to EC2)												
Nominal yield strength - tension	f_{yk}	[N/mm ²]	410	410	410	410	410	410	410	410	410	410
Cross sectional area - tension	A_s	[mm ²]	50.3	78.5	113.1	153.9	201.1	314.2	490.9	615.8	706.9	804.2
fyk = 420 (e.g. G-60 acc. to ASTM 615)												
Nominal yield strength - tension	f_{yk}	[N/mm ²]	420	420	420	420	420	420	420	420	420	420
Cross sectional area - tension	A_s	[mm ²]	50.3	78.5	113.1	153.9	201.1	314.2	490.9	615.8	706.9	804.2
fyk = 460 (e.g. 460 B acc. to BS 4449)												
Nominal yield strength - tension	f_{yk}	[N/mm ²]	460	460	460	460	460	460	460	460	460	460
Cross sectional area - tension	A_s	[mm ²]	50.3	78.5	113.1	153.9	201.1	314.2	490.9	615.8	706.9	804.2
fyk = 500 (e.g. B 500 SP acc. to EC2; 500 B acc. to BS 4449; B 500 B acc. to SS 560)												
Nominal yield strength - tension	f_{yk}	[N/mm ²]	500	500	500	500	500	500	500	500	500	500
Cross sectional area - tension	A_s	[mm ²]	50.3	78.5	113.1	153.9	201.1	314.2	490.9	615.8	706.9	804.2
fyk = 600 (e.g. B 600 B acc. to SS 560)												
Nominal yield strength - tension	f_{yk}	[N/mm ²]	600	600	600	600	600	600	600	600	600	600
Cross sectional area - tension	A_s	[mm ²]	50.3	78.5	113.1	153.9	201.1	314.2	490.9	615.8	706.9	804.2

Basic performance data

ANCHORAGES – DESIGN RESISTANCE – CONCRETE C20/25, NOMINAL YIELD STRENGTH FOR TENSION - $f_{yk} = 410$ [N/mm ²]																										
l_{bd} [mm]	d_s [mm]	100	120	140	160	180	200	230	260	290	320	350	400	450	500	550	600	650	700	750	800	850	900	950	1000	Steel failure
8		5,8	6,9	8,1	9,2	10,4	11,6	13,3	15,0	16,8	17,9	17,9	17,9	-	-	-	-	-	-	-	-	-	-	-	-	17,9
10		-	8,7	10,1	11,6	13,0	14,5	16,6	18,8	21,0	23,1	25,3	28,0	28,0	28,0	-	-	-	-	-	-	-	-	-	-	28,0
12		-	-	12,1	13,9	15,6	17,3	19,9	22,5	25,1	27,7	30,3	34,7	39,0	40,3	40,3	40,3	-	-	-	-	-	-	-	-	40,3
14		-	-	-	-	18,2	20,2	23,3	26,3	29,3	32,4	35,4	40,5	45,5	50,6	54,9	54,9	54,9	54,9	-	-	-	-	-	-	54,9
16		-	-	-	-	-	23,1	26,6	30,1	33,5	37,0	40,5	46,2	52,0	57,8	63,6	69,4	71,7	71,7	71,7	71,7	-	-	-	-	71,7
20		-	-	-	-	-	-	-	37,6	41,9	46,2	50,6	57,8	65,0	72,3	79,5	86,7	93,9	101,2	108,4	112,0	112,0	112,0	112,0	112,0	112,0
25		-	-	-	-	-	-	-	-	-	57,8	63,2	72,3	81,3	90,3	99,4	108,4	117,4	126,4	135,5	144,5	153,5	162,6	171,6	175,0	175,0
28		-	-	-	-	-	-	-	-	-	-	70,8	80,9	91,0	101,2	111,3	121,4	131,5	141,6	151,7	161,9	172,0	182,1	192,2	202,3	219,5
30		-	-	-	-	-	-	-	-	-	-	75,9	86,7	97,5	108,4	119,2	130,1	140,9	151,7	162,6	173,4	184,3	195,1	205,9	216,8	252,0
32		-	-	-	-	-	-	-	-	-	-	-	92,5	104,0	115,6	127,2	138,7	150,3	161,9	173,4	185,0	196,5	208,1	219,7	231,2	286,7

ANCHORAGES – DESIGN RESISTANCE – CONCRETE C50/60, NOMINAL YIELD STRENGTH FOR TENSION - $f_{yk} = 410$ [N/mm ²]																										
l_{bd} [mm]	d_s [mm]	100	120	140	160	180	200	225	250	275	300	350	400	450	500	550	600	650	700	750	800	850	900	950	1000	Steel failure
8		10,8	13,0	15,1	17,3	17,9	17,9	17,9	17,9	17,9	17,9	17,9	17,9	-	-	-	-	-	-	-	-	-	-	-	-	17,9
10		13,5	16,2	18,9	21,6	24,3	27,0	28,0	28,0	28,0	28,0	28,0	28,0	28,0	28,0	-	-	-	-	-	-	-	-	-	-	28,0
12		-	19,5	22,7	25,9	29,2	32,4	36,5	40,3	40,3	40,3	40,3	40,3	40,3	40,3	40,3	40,3	-	-	-	-	-	-	-	-	40,3
14		-	-	26,5	30,3	34,0	37,8	42,6	47,3	52,0	54,9	54,9	54,9	54,9	54,9	54,9	54,9	54,9	54,9	-	-	-	-	-	-	54,9
16		-	-	-	32,2	36,2	40,2	45,2	50,3	55,3	60,3	70,4	71,7	71,7	71,7	71,7	71,7	71,7	71,7	71,7	71,7	-	-	-	-	71,7
20		-	-	-	-	-	46,5	52,3	58,1	63,9	69,7	81,4	93,0	104,6	112,0	112,0	112,0	112,0	112,0	112,0	112,0	112,0	112,0	112,0	112,0	112,0
25		-	-	-	-	-	-	-	58,9	64,8	70,7	82,5	94,2	106,0	117,8	129,6	141,4	153,2	164,9	175,0	175,0	175,0	175,0	175,0	175,0	175,0
28		-	-	-	-	-	-	-	-	-	79,2	92,4	105,6	118,8	131,9	145,1	158,3	171,5	184,7	197,9	211,1	219,5	219,5	219,5	219,5	219,5
30		-	-	-	-	-	-	-	-	-	76,3	89,1	101,8	114,5	127,2	140,0	152,7	165,4	178,1	190,9	203,6	216,3	229,0	241,7	252,0	252,0
32		-	-	-	-	-	-	-	-	-	-	95,0	108,6	122,1	135,7	149,3	162,9	176,4	190,0	203,6	217,1	230,7	244,3	257,9	271,4	286,7

Basic performance data (cont.)

OVERLAP SPLICE – DESIGN RESISTANCE – CONCRETE C20/25, NOMINAL YIELD STRENGTH FOR TENSION - $f_{yk} = 410$ [N/mm ²]																										
l_{bd} [mm]	d_s [mm]	200	220	240	260	280	300	325	350	375	400	425	450	475	500	550	600	650	700	750	800	850	900	950	1000	Steel failure
8		11,6	12,7	13,9	15,0	16,2	17,3	17,9	17,9	17,9	-	-	-	-	-	-	-	-	-	-	-	-	-	-	-	17,9
10		14,5	15,9	17,3	18,8	20,2	21,7	23,5	25,3	27,1	28,0	28,0	28,0	28,0	-	-	-	-	-	-	-	-	-	-	-	28,0
12		-	19,1	20,8	22,5	24,3	26,0	28,2	30,3	32,5	34,7	36,9	39,0	40,3	40,3	40,3	-	-	-	-	-	-	-	-	-	40,3
14		-	-	-	26,3	28,3	30,3	32,9	35,4	37,9	40,5	43,0	45,5	48,1	50,6	54,9	54,9	54,9	54,9	-	-	-	-	-	-	54,9
16		-	-	-	-	32,4	34,7	37,6	40,5	43,4	46,2	49,1	52,0	54,9	57,8	63,6	69,4	71,7	71,7	71,7	71,7	-	-	-	-	71,7
20		-	-	-	-	-	-	-	50,6	54,2	57,8	61,4	65,0	68,6	72,3	79,5	86,7	93,9	101,2	108,4	112,0	112,0	112,0	112,0	112,0	112,0
25		-	-	-	-	-	-	-	-	-	-	-	81,3	85,8	90,3	99,4	108,4	117,4	126,4	135,5	144,5	153,5	162,6	171,6	175,0	175,0
28		-	-	-	-	-	-	-	-	-	-	-	-	-	101,2	111,3	121,4	131,5	141,6	151,7	161,9	172,0	182,1	192,2	202,3	219,5
30		-	-	-	-	-	-	-	-	-	-	-	-	-	-	119,2	130,1	140,9	151,7	162,6	173,4	184,3	195,1	205,9	216,8	252,0
32		-	-	-	-	-	-	-	-	-	-	-	-	-	-	-	138,7	150,3	161,9	173,4	185,0	196,5	208,1	219,7	231,2	286,7

OVERLAP SPLICE – DESIGN RESISTANCE – CONCRETE C50/60, NOMINAL YIELD STRENGTH FOR TENSION - $f_{yk} = 410$ [N/mm ²]																										
l_{bd} [mm]	d_s [mm]	200	220	240	260	280	300	325	350	375	400	425	450	475	500	550	600	650	700	750	800	850	900	950	1000	Steel failure
8		17,9	17,9	17,9	17,9	17,9	17,9	17,9	17,9	17,9	-	-	-	-	-	-	-	-	-	-	-	-	-	-	-	17,9
10		27,0	28,0	28,0	28,0	28,0	28,0	28,0	28,0	28,0	28,0	28,0	28,0	28,0	-	-	-	-	-	-	-	-	-	-	-	28,0
12		32,4	35,7	38,9	40,3	40,3	40,3	40,3	40,3	40,3	40,3	40,3	40,3	40,3	40,3	40,3	-	-	-	-	-	-	-	-	-	40,3
14		-	41,6	45,4	49,2	53,0	54,9	54,9	54,9	54,9	54,9	54,9	54,9	54,9	54,9	54,9	54,9	54,9	54,9	-	-	-	-	-	-	54,9
16		-	-	48,3	52,3	56,3	60,3	65,3	70,4	71,7	71,7	71,7	71,7	71,7	71,7	71,7	71,7	71,7	71,7	71,7	-	-	-	-	-	71,7
20		-	-	-	-	-	69,7	75,6	81,4	87,2	93,0	98,8	104,6	110,4	112,0	112,0	112,0	112,0	112,0	112,0	112,0	112,0	112,0	112,0	112,0	112,0
25		-	-	-	-	-	-	-	-	88,4	94,2	100,1	106,0	111,9	117,8	129,6	141,4	153,2	164,9	175,0	175,0	175,0	175,0	175,0	175,0	175,0
28		-	-	-	-	-	-	-	-	-	-	112,2	118,8	125,3	131,9	145,1	158,3	171,5	184,7	197,9	211,1	219,5	219,5	219,5	219,5	219,5
30		-	-	-	-	-	-	-	-	-	-	-	114,5	120,9	127,2	140,0	152,7	165,4	178,1	190,9	203,6	216,3	229,0	241,7	252,0	252,0
32		-	-	-	-	-	-	-	-	-	-	-	-	-	135,7	149,3	162,9	176,4	190,0	203,6	217,1	230,7	244,3	257,9	271,4	286,7

ANCHORAGES – DESIGN RESISTANCE – CONCRETE C20/25, NOMINAL YIELD STRENGTH FOR TENSION - $f_{yk} = 420$ [N/mm ²]																										
l_{bd} [mm]	d_s [mm]	100	120	140	160	180	200	230	260	290	320	350	400	450	500	550	600	650	700	750	800	850	900	950	1000	Steel failure
8		5,8	6,9	8,1	9,2	10,4	11,6	13,3	15,0	16,8	18,4	18,4	18,4	-	-	-	-	-	-	-	-	-	-	-	-	18,4
10		-	8,7	10,1	11,6	13,0	14,5	16,6	18,8	21,0	23,1	25,3	28,7	28,7	28,7	-	-	-	-	-	-	-	-	-	-	28,7
12		-	-	-	13,9	15,6	17,3	19,9	22,5	25,1	27,7	30,3	34,7	39,0	41,3	41,3	41,3	-	-	-	-	-	-	-	-	41,3
14		-	-	-	-	18,2	20,2	23,3	26,3	29,3	32,4	35,4	40,5	45,5	50,6	55,6	56,2	56,2	56,2	-	-	-	-	-	-	56,2
16		-	-	-	-	-	23,1	26,6	30,1	33,5	37,0	40,5	46,2	52,0	57,8	63,6	69,4	73,4	73,4	73,4	73,4	-	-	-	-	73,4
20		-	-	-	-	-	-	-	37,6	41,9	46,2	50,6	57,8	65,0	72,3	79,5	86,7	93,9	101,2	108,4	114,8	114,8	114,8	114,8	114,8	114,8
25		-	-	-	-	-	-	-	-	-	57,8	63,2	72,3	81,3	90,3	99,4	108,4	117,4	126,4	135,5	144,5	153,5	162,6	171,6	179,3	179,3
28		-	-	-	-	-	-	-	-	-	-	70,8	80,9	91,0	101,2	111,3	121,4	131,5	141,6	151,7	161,9	172,0	182,1	192,2	202,3	224,9
30		-	-	-	-	-	-	-	-	-	-	-	86,7	97,5	108,4	119,2	130,1	140,9	151,7	162,6	173,4	184,3	195,1	205,9	216,8	258,2
32		-	-	-	-	-	-	-	-	-	-	-	92,5	104,0	115,6	127,2	138,7	150,3	161,9	173,4	185,0	196,5	208,1	219,7	231,2	293,7

ANCHORAGES – DESIGN RESISTANCE – CONCRETE C50/60, NOMINAL YIELD STRENGTH FOR TENSION - $f_{yk} = 420$ [N/mm ²]																										
l_{bd} [mm]	d_s [mm]	100	120	140	160	180	200	230	260	290	320	350	400	450	500	550	600	650	700	750	800	850	900	950	1000	Steel failure
8		10,8	13,0	15,1	17,3	18,4	18,4	18,4	18,4	18,4	18,4	18,4	18,4	-	-	-	-	-	-	-	-	-	-	-	-	18,4
10		13,5	16,2	18,9	21,6	24,3	27,0	28,7	28,7	28,7	28,7	28,7	28,7	28,7	28,7	-	-	-	-	-	-	-	-	-	-	28,7
12		-	19,5	22,7	25,9	29,2	32,4	37,3	41,3	41,3	41,3	41,3	41,3	41,3	41,3	41,3	-	-	-	-	-	-	-	-	-	41,3
14		-	-	26,5	30,3	34,0	37,8	43,5	49,2	54,8	56,2	56,2	56,2	56,2	56,2	56,2	56,2	56,2	56,2	-	-	-	-	-	-	56,2
16		-	-	-	32,2	36,2	40,2	46,2	52,3	58,3	64,3	70,4	73,4	73,4	73,4	73,4	73,4	73,4	73,4	73,4	73,4	-	-	-	-	73,4
20		-	-	-	-	-	46,5	53,5	60,4	67,4	74,4	81,4	93,0	104,6	114,8	114,8	114,8	114,8	114,8	114,8	114,8	114,8	114,8	114,8	114,8	114,8
25		-	-	-	-	-	-	-	61,3	68,3	75,4	82,5	94,2	106,0	117,8	129,6	141,4	153,2	164,9	176,7	179,3	179,3	179,3	179,3	179,3	179,3
28		-	-	-	-	-	-	-	-	76,5	84,4	92,4	105,6	118,8	131,9	145,1	158,3	171,5	184,7	197,9	211,1	224,3	224,9	224,9	224,9	224,9
30		-	-	-	-	-	-	-	-	-	81,4	89,1	101,8	114,5	127,2	140,0	152,7	165,4	178,1	190,9	203,6	216,3	229,0	241,7	254,5	258,2
32		-	-	-	-	-	-	-	-	-	-	95,0	108,6	122,1	135,7	149,3	162,9	176,4	190,0	203,6	217,1	230,7	244,3	257,9	271,4	293,7

All products listed in this publication are branded and distributed with RAWLPLUG® or RAWL® trademarks.

Basic performance data (cont.)

OVERLAP SPLICE – DESIGN RESISTANCE – CONCRETE C20/25, NOMINAL YIELD STRENGTH FOR TENSION - $f_{yk} = 420$ [N/mm ²]																									
$\frac{l_{bd}}{d_s}$	200	220	240	260	280	300	325	350	375	400	425	450	475	500	550	600	650	700	750	800	850	900	950	1000	Steel failure
8	11,6	12,7	13,9	15,0	16,2	17,3	18,4	18,4	18,4	18,4	-	-	-	-	-	-	-	-	-	-	-	-	-	-	18,4
10	14,5	15,9	17,3	18,8	20,2	21,7	23,5	25,3	27,1	28,7	28,7	28,7	28,7	28,7	-	-	-	-	-	-	-	-	-	-	28,7
12	-	19,1	20,8	22,5	24,3	26,0	28,2	30,3	32,5	34,7	36,9	39,0	41,2	41,3	41,3	41,3	-	-	-	-	-	-	-	-	41,3
14	-	-	-	26,3	28,3	30,3	32,9	35,4	37,9	40,5	43,0	45,5	48,1	50,6	55,6	56,2	56,2	56,2	-	-	-	-	-	-	56,2
16	-	-	-	-	-	34,7	37,6	40,5	43,4	46,2	49,1	52,0	54,9	57,8	63,6	69,4	73,4	73,4	73,4	73,4	-	-	-	-	73,4
20	-	-	-	-	-	-	-	-	54,2	57,8	61,4	65,0	68,6	72,3	79,5	86,7	93,9	101,2	108,4	114,8	114,8	114,8	114,8	114,8	114,8
25	-	-	-	-	-	-	-	-	-	-	-	81,3	85,8	90,3	99,4	108,4	117,4	126,4	135,5	144,5	153,5	162,6	171,6	179,3	179,3
28	-	-	-	-	-	-	-	-	-	-	-	-	-	-	111,3	121,4	131,5	141,6	151,7	161,9	172,0	182,1	192,2	202,3	224,9
30	-	-	-	-	-	-	-	-	-	-	-	-	-	-	119,2	130,1	140,9	151,7	162,6	173,4	184,3	195,1	205,9	216,8	258,2
32	-	-	-	-	-	-	-	-	-	-	-	-	-	-	-	138,7	150,3	161,9	173,4	185,0	196,5	208,1	219,7	231,2	293,7

OVERLAP SPLICE – DESIGN RESISTANCE – CONCRETE C50/60, NOMINAL YIELD STRENGTH FOR TENSION - $f_{yk} = 420$ [N/mm ²]																									
$\frac{l_{bd}}{d_s}$	200	220	240	260	280	300	325	350	375	400	425	450	475	500	550	600	650	700	750	800	850	900	950	1000	Steel failure
8	18,4	18,4	18,4	18,4	18,4	18,4	18,4	18,4	18,4	18,4	-	-	-	-	-	-	-	-	-	-	-	-	-	-	18,4
10	27,0	28,7	28,7	28,7	28,7	28,7	28,7	28,7	28,7	28,7	28,7	28,7	28,7	28,7	-	-	-	-	-	-	-	-	-	-	28,7
12	32,4	35,7	38,9	41,3	41,3	41,3	41,3	41,3	41,3	41,3	41,3	41,3	41,3	41,3	41,3	41,3	-	-	-	-	-	-	-	-	41,3
14	-	41,6	45,4	49,2	53,0	56,2	56,2	56,2	56,2	56,2	56,2	56,2	56,2	56,2	56,2	56,2	56,2	56,2	-	-	-	-	-	-	56,2
16	-	-	48,3	52,3	56,3	60,3	65,3	70,4	73,4	73,4	73,4	73,4	73,4	73,4	73,4	73,4	73,4	73,4	73,4	73,4	-	-	-	-	73,4
20	-	-	-	-	-	69,7	75,6	81,4	87,2	93,0	98,8	104,6	110,4	114,8	114,8	114,8	114,8	114,8	114,8	114,8	114,8	114,8	114,8	114,8	114,8
25	-	-	-	-	-	-	-	-	88,4	94,2	100,1	106,0	111,9	117,8	129,6	141,4	153,2	164,9	176,7	179,3	179,3	179,3	179,3	179,3	179,3
28	-	-	-	-	-	-	-	-	-	112,2	118,8	125,3	131,9	145,1	158,3	171,5	184,7	197,9	211,1	224,3	224,9	224,9	224,9	224,9	224,9
30	-	-	-	-	-	-	-	-	-	-	-	120,9	127,2	140,0	152,7	165,4	178,1	190,9	203,6	216,3	229,0	241,7	254,5	258,2	258,2
32	-	-	-	-	-	-	-	-	-	-	-	-	-	135,7	149,3	162,9	176,4	190,0	203,6	217,1	230,7	244,3	257,9	271,4	293,7

ANCHORAGES – DESIGN RESISTANCE – CONCRETE C20/25, NOMINAL YIELD STRENGTH FOR TENSION - $f_{yk} = 460$ [N/mm ²]																									
$\frac{l_{bd}}{d_s}$	100	120	140	160	180	200	230	260	290	320	350	400	450	500	550	600	650	700	750	800	850	900	950	1000	Steel failure
8	-	6,9	8,1	9,2	10,4	11,6	13,3	15,0	16,8	18,5	20,1	20,1	-	-	-	-	-	-	-	-	-	-	-	-	20,1
10	-	-	10,1	11,6	13,0	14,5	16,6	18,8	21,0	23,1	25,3	28,9	31,4	31,4	-	-	-	-	-	-	-	-	-	-	31,4
12	-	-	-	13,9	15,6	17,3	19,9	22,5	25,1	27,7	30,3	34,7	39,0	43,4	45,2	45,2	-	-	-	-	-	-	-	-	45,2
14	-	-	-	-	-	20,2	23,3	26,3	29,3	32,4	35,4	40,5	45,5	50,6	55,6	60,7	61,6	61,6	-	-	-	-	-	-	61,6
16	-	-	-	-	-	-	26,6	30,1	33,5	37,0	40,5	46,2	52,0	57,8	63,6	69,4	75,1	80,4	80,4	80,4	-	-	-	-	80,4
20	-	-	-	-	-	-	-	-	41,9	46,2	50,6	57,8	65,0	72,3	79,5	86,7	93,9	101,2	108,4	115,6	122,8	125,7	125,7	125,7	125,7
25	-	-	-	-	-	-	-	-	-	63,2	72,3	81,3	90,3	99,4	108,4	117,4	126,4	135,5	144,5	153,5	162,6	171,6	180,6	196,4	196,4
28	-	-	-	-	-	-	-	-	-	-	80,9	91,0	101,2	111,3	121,4	131,5	141,6	151,7	161,9	172,0	182,1	192,2	202,3	246,3	246,3
30	-	-	-	-	-	-	-	-	-	-	-	86,7	97,5	108,4	119,2	130,1	140,9	151,7	162,6	173,4	184,3	195,1	205,9	216,8	282,7
32	-	-	-	-	-	-	-	-	-	-	-	-	104,0	115,6	127,2	138,7	150,3	161,9	173,4	185,0	196,5	208,1	219,7	231,2	321,7

ANCHORAGES – DESIGN RESISTANCE – CONCRETE C50/60, NOMINAL YIELD STRENGTH FOR TENSION - $f_{yk} = 460$ [N/mm ²]																									
$\frac{l_{bd}}{d_s}$	100	120	140	160	180	200	230	260	290	320	350	400	450	500	550	600	650	700	750	800	850	900	950	1000	Steel failure
8	10,8	13,0	15,1	17,3	19,5	20,1	20,1	20,1	20,1	20,1	20,1	-	-	-	-	-	-	-	-	-	-	-	-	-	20,1
10	13,5	16,2	18,9	21,6	24,3	27,0	31,1	31,4	31,4	31,4	31,4	31,4	31,4	31,4	-	-	-	-	-	-	-	-	-	-	31,4
12	-	19,5	22,7	25,9	29,2	32,4	37,3	42,1	45,2	45,2	45,2	45,2	45,2	45,2	45,2	45,2	-	-	-	-	-	-	-	-	45,2
14	-	-	26,5	30,3	34,0	37,8	43,5	49,2	54,8	60,5	61,6	61,6	61,6	61,6	61,6	61,6	61,6	61,6	-	-	-	-	-	-	61,6
16	-	-	-	32,2	36,2	40,2	46,2	52,3	58,3	64,3	70,4	80,4	80,4	80,4	80,4	80,4	80,4	80,4	80,4	80,4	-	-	-	-	80,4
20	-	-	-	-	-	46,5	53,5	60,4	67,4	74,4	81,4	93,0	104,6	116,2	125,7	125,7	125,7	125,7	125,7	125,7	125,7	125,7	125,7	125,7	125,7
25	-	-	-	-	-	-	-	61,3	68,3	75,4	82,5	94,2	106,0	117,8	129,6	141,4	153,2	164,9	176,7	188,5	196,4	196,4	196,4	196,4	196,4
28	-	-	-	-	-	-	-	-	76,5	84,4	92,4	105,6	118,8	131,9	145,1	158,3	171,5	184,7	197,9	211,1	224,3	237,5	246,3	246,3	246,3
30	-	-	-	-	-	-	-	-	-	89,1	101,8	114,5	127,2	140,0	152,7	165,4	178,1	190,9	203,6	216,3	229,0	241,7	254,5	282,7	282,7
32	-	-	-	-	-	-	-	-	-	-	108,6	122,1	135,7	149,3	162,9	176,4	190,0	203,6	217,1	230,7	244,3	257,9	271,4	321,7	321,7

Basic performance data (cont.)

OVERLAP SPLICE – DESIGN RESISTANCE – CONCRETE C20/25, NOMINAL YIELD STRENGTH FOR TENSION - $f_{yk} = 460$ [N/mm ²]																											
$\frac{l_{bd}}{d_s}$	d_s	200	220	240	260	280	300	325	350	375	400	425	450	475	500	550	600	650	700	750	800	850	900	950	1000	Steel failure	
8	8	11,6	12,7	13,9	15,0	16,2	17,3	18,8	20,1	20,1	-	-	-	-	-	-	-	-	-	-	-	-	-	-	-	20,1	
10	10	14,5	15,9	17,3	18,8	20,2	21,7	23,5	25,3	27,1	28,9	30,7	31,4	31,4	31,4	-	-	-	-	-	-	-	-	-	-	-	31,4
12	12	-	-	20,8	22,5	24,3	26,0	28,2	30,3	32,5	34,7	36,9	39,0	41,2	43,4	45,2	45,2	-	-	-	-	-	-	-	-	-	45,2
14	14	-	-	-	-	28,3	30,3	32,9	35,4	37,9	40,5	43,0	45,5	48,1	50,6	55,6	60,7	61,6	61,6	-	-	-	-	-	-	-	61,6
16	16	-	-	-	-	-	-	37,6	40,5	43,4	46,2	49,1	52,0	54,9	57,8	63,6	69,4	75,1	80,4	80,4	80,4	-	-	-	-	-	80,4
20	20	-	-	-	-	-	-	-	-	-	57,8	61,4	65,0	68,6	72,3	79,5	86,7	93,9	101,2	108,4	115,6	122,8	125,7	125,7	125,7	125,7	125,7
25	25	-	-	-	-	-	-	-	-	-	-	-	-	-	90,3	99,4	108,4	117,4	126,4	135,5	144,5	153,5	162,6	171,6	180,6	196,4	196,4
28	28	-	-	-	-	-	-	-	-	-	-	-	-	-	-	111,3	121,4	131,5	141,6	151,7	161,9	172,0	182,1	192,2	202,3	246,3	246,3
30	30	-	-	-	-	-	-	-	-	-	-	-	-	-	-	-	130,1	140,9	151,7	162,6	173,4	184,3	195,1	205,9	216,8	282,7	282,7
32	32	-	-	-	-	-	-	-	-	-	-	-	-	-	-	-	-	150,3	161,9	173,4	185,0	196,5	208,1	219,7	231,2	321,7	321,7

OVERLAP SPLICE – DESIGN RESISTANCE – CONCRETE C50/60, NOMINAL YIELD STRENGTH FOR TENSION - $f_{yk} = 460$ [N/mm ²]																											
$\frac{l_{bd}}{d_s}$	d_s	200	220	240	260	280	300	325	350	375	400	425	450	475	500	550	600	650	700	750	800	850	900	950	1000	Steel failure	
8	8	20,1	20,1	20,1	20,1	20,1	20,1	20,1	20,1	20,1	-	-	-	-	-	-	-	-	-	-	-	-	-	-	-	-	20,1
10	10	27,0	29,7	31,4	31,4	31,4	31,4	31,4	31,4	31,4	31,4	31,4	31,4	31,4	31,4	-	-	-	-	-	-	-	-	-	-	-	31,4
12	12	32,4	35,7	38,9	42,1	45,2	45,2	45,2	45,2	45,2	45,2	45,2	45,2	45,2	45,2	45,2	45,2	-	-	-	-	-	-	-	-	-	45,2
14	14	-	41,6	45,4	49,2	53,0	56,7	61,5	61,6	61,6	61,6	61,6	61,6	61,6	61,6	61,6	61,6	61,6	61,6	-	-	-	-	-	-	-	61,6
16	16	-	-	48,3	52,3	56,3	60,3	65,3	70,4	75,4	80,4	80,4	80,4	80,4	80,4	80,4	80,4	80,4	80,4	80,4	80,4	-	-	-	-	-	80,4
20	20	-	-	-	-	-	69,7	75,6	81,4	87,2	93,0	98,8	104,6	110,4	116,2	125,7	125,7	125,7	125,7	125,7	125,7	125,7	125,7	125,7	125,7	125,7	125,7
25	25	-	-	-	-	-	-	-	-	88,4	94,2	100,1	106,0	111,9	117,8	129,6	141,4	153,2	164,9	176,7	188,5	196,4	196,4	196,4	196,4	196,4	196,4
28	28	-	-	-	-	-	-	-	-	-	112,2	118,8	125,3	131,9	145,1	158,3	171,5	184,7	197,9	211,1	224,3	237,5	246,3	246,3	246,3	246,3	246,3
30	30	-	-	-	-	-	-	-	-	-	-	-	-	-	127,2	140,0	152,7	165,4	178,1	190,9	203,6	216,3	229,0	241,7	254,5	282,7	282,7
32	32	-	-	-	-	-	-	-	-	-	-	-	-	-	-	149,3	162,9	176,4	190,0	203,6	217,1	230,7	244,3	257,9	271,4	321,7	321,7

ANCHORAGES – DESIGN RESISTANCE – CONCRETE C20/25, NOMINAL YIELD STRENGTH FOR TENSION - $f_{yk} = 500$ [N/mm ²]																											
$\frac{l_{bd}}{d_s}$	d_s	100	120	140	160	180	200	230	260	290	320	350	400	450	500	550	600	650	700	750	800	850	900	950	1000	Steel failure	
8	8	-	6,9	8,1	9,2	10,4	11,6	13,3	15,0	16,8	18,5	20,2	21,9	-	-	-	-	-	-	-	-	-	-	-	-	-	21,9
10	10	-	-	-	11,6	13,0	14,5	16,6	18,8	21,0	23,1	25,3	28,9	32,5	34,1	-	-	-	-	-	-	-	-	-	-	-	34,1
12	12	-	-	-	-	15,6	17,3	19,9	22,5	25,1	27,7	30,3	34,7	39,0	43,4	47,7	49,2	-	-	-	-	-	-	-	-	-	49,2
14	14	-	-	-	-	-	20,2	23,3	26,3	29,3	32,4	35,4	40,5	45,5	50,6	55,6	60,7	65,8	66,9	-	-	-	-	-	-	-	66,9
16	16	-	-	-	-	-	-	26,6	30,1	33,5	37,0	40,5	46,2	52,0	57,8	63,6	69,4	75,1	80,9	86,7	87,4	-	-	-	-	-	87,4
20	20	-	-	-	-	-	-	-	-	41,9	46,2	50,6	57,8	65,0	72,3	79,5	86,7	93,9	101,2	108,4	115,6	122,8	130,1	136,6	136,6	136,6	136,6
25	25	-	-	-	-	-	-	-	-	-	-	-	72,3	81,3	90,3	99,4	108,4	117,4	126,4	135,5	144,5	153,5	162,6	171,6	180,6	213,4	213,4
28	28	-	-	-	-	-	-	-	-	-	-	-	80,9	91,0	101,2	111,3	121,4	131,5	141,6	151,7	161,9	172,0	182,1	192,2	202,3	267,7	267,7
30	30	-	-	-	-	-	-	-	-	-	-	-	-	97,5	108,4	119,2	130,1	140,9	151,7	162,6	173,4	184,3	195,1	205,9	216,8	307,3	307,3
32	32	-	-	-	-	-	-	-	-	-	-	-	-	-	115,6	127,2	138,7	150,3	161,9	173,4	185,0	196,5	208,1	219,7	231,2	349,7	349,7

ANCHORAGES – DESIGN RESISTANCE – CONCRETE C50/60, NOMINAL YIELD STRENGTH FOR TENSION - $f_{yk} = 500$ [N/mm ²]																											
$\frac{l_{bd}}{d_s}$	d_s	100	120	140	160	180	200	230	260	290	320	350	400	450	500	550	600	650	700	750	800	850	900	950	1000	Steel failure	
8	8	10,8	13,0	15,1	17,3	19,5	21,6	21,9	21,9	21,9	21,9	21,9	21,9	-	-	-	-	-	-	-	-	-	-	-	-	-	21,9
10	10	13,5	16,2	18,9	21,6	24,3	27,0	31,1	34,1	34,1	34,1	34,1	34,1	34,1	34,1	-	-	-	-	-	-	-	-	-	-	-	34,1
12	12	-	19,5	22,7	25,9	29,2	32,4	37,3	42,1	47,0	49,2	49,2	49,2	49,2	49,2	49,2	49,2	-	-	-	-	-	-	-	-	-	49,2
14	14	-	-	26,5	30,3	34,0	37,8	43,5	49,2	54,8	60,5	66,2	66,9	66,9	66,9	66,9	66,9	66,9	66,9	-	-	-	-	-	-	-	66,9
16	16	-	-	-	32,2	36,2	40,2	46,2	52,3	58,3	64,3	70,4	80,4	87,4	87,4	87,4	87,4	87,4	87,4	87,4	87,4	-	-	-	-	-	87,4
20	20	-	-	-	-	-	46,5	53,5	60,4	67,4	74,4	81,4	93,0	104,6	116,2	127,9	136,6	136,6	136,6	136,6	136,6	136,6	136,6	136,6	136,6	136,6	136,6
25	25	-	-	-	-	-	-	-	-	68,3	75,4	82,5	94,2	106,0	117,8	129,6	141,4	153,2	164,9	176,7	188,5	200,3	212,1	213,4	213,4	213,4	213,4
28	28	-	-	-	-	-	-	-	-	-	84,4	92,4	105,6	118,8	131,9	145,1	158,3	171,5	184,7	197,9	211,1	224,3	237,5	250,7	263,9	267,7	267,7
30	30	-	-	-	-	-	-	-	-	-	-	-	101,8	114,5	127,2	140,0	152,7	165,4	178,1	190,9	203,6	216,3	229,0	241,7	254,5	307,3	307,3
32	32	-	-	-	-	-	-	-	-	-	-	-	108,6	122,1	135,7	149,3	162,9	176,4	190,0	203,6	217,1	230,7	244,3	257,9	271,4	349,7	349,7

All products listed in this publication are branded and distributed with RAWLPLUG® or RAWL® trademarks.

Basic performance data (cont.)

OVERLAP SPLICE – DESIGN RESISTANCE – CONCRETE C20/25, NOMINAL YIELD STRENGTH FOR TENSION - $f_{yk} = 500$ [N/mm ²]																										
$\frac{l_{bd}}{d_s}$	d_s [mm]	200	220	240	260	280	300	325	350	375	400	425	450	475	500	550	600	650	700	750	800	850	900	950	1000	Steel failure
		8	11,6	12,7	13,9	15,0	16,2	17,3	18,8	20,2	21,7	21,9	-	-	-	-	-	-	-	-	-	-	-	-	-	-
10	-	15,9	17,3	18,8	20,2	21,7	23,5	25,3	27,1	28,9	30,7	32,5	34,1	34,1	-	-	-	-	-	-	-	-	-	-	-	34,1
12	-	-	-	22,5	24,3	26,0	28,2	30,3	32,5	34,7	36,9	39,0	41,2	43,4	47,7	49,2	-	-	-	-	-	-	-	-	-	49,2
14	-	-	-	-	-	30,3	32,9	35,4	37,9	40,5	43,0	45,5	48,1	50,6	55,6	60,7	65,8	66,9	-	-	-	-	-	-	-	66,9
16	-	-	-	-	-	-	-	40,5	43,4	46,2	49,1	52,0	54,9	57,8	63,6	69,4	75,1	80,9	86,7	87,4	-	-	-	-	-	87,4
20	-	-	-	-	-	-	-	-	-	-	-	65,0	68,6	72,3	79,5	86,7	93,9	101,2	108,4	115,6	122,8	130,1	136,6	136,6	136,6	136,6
25	-	-	-	-	-	-	-	-	-	-	-	-	-	-	99,4	108,4	117,4	126,4	135,5	144,5	153,5	162,6	171,6	180,6	180,6	213,4
28	-	-	-	-	-	-	-	-	-	-	-	-	-	-	-	121,4	131,5	141,6	151,7	161,9	172,0	182,1	192,2	202,3	202,3	267,7
30	-	-	-	-	-	-	-	-	-	-	-	-	-	-	-	-	140,9	151,7	162,6	173,4	184,3	195,1	205,9	216,8	216,8	307,3
32	-	-	-	-	-	-	-	-	-	-	-	-	-	-	-	-	-	161,9	173,4	185,0	196,5	208,1	219,7	231,2	231,2	349,7

OVERLAP SPLICE – DESIGN RESISTANCE – CONCRETE C50/60, NOMINAL YIELD STRENGTH FOR TENSION - $f_{yk} = 500$ [N/mm ²]																										
$\frac{l_{bd}}{d_s}$	d_s [mm]	200	220	240	260	280	300	325	350	375	400	425	450	475	500	550	600	650	700	750	800	850	900	950	1000	Steel failure
		8	21,6	21,9	21,9	21,9	21,9	21,9	21,9	21,9	21,9	21,9	-	-	-	-	-	-	-	-	-	-	-	-	-	-
10	27,0	29,7	32,4	34,1	34,1	34,1	34,1	34,1	34,1	34,1	34,1	34,1	34,1	34,1	-	-	-	-	-	-	-	-	-	-	-	34,1
12	32,4	35,7	38,9	42,1	45,4	48,6	49,2	49,2	49,2	49,2	49,2	49,2	49,2	49,2	49,2	49,2	-	-	-	-	-	-	-	-	-	49,2
14	-	41,6	45,4	49,2	53,0	56,7	61,5	66,2	66,9	66,9	66,9	66,9	66,9	66,9	66,9	66,9	66,9	66,9	66,9	-	-	-	-	-	-	66,9
16	-	-	48,3	52,3	56,3	60,3	65,3	70,4	75,4	80,4	85,5	87,4	87,4	87,4	87,4	87,4	87,4	87,4	87,4	87,4	87,4	-	-	-	-	87,4
20	-	-	-	-	-	69,7	75,6	81,4	87,2	93,0	98,8	104,6	110,4	116,2	127,9	136,6	136,6	136,6	136,6	136,6	136,6	136,6	136,6	136,6	136,6	136,6
25	-	-	-	-	-	-	-	-	-	100,1	106,0	111,9	117,8	129,6	141,4	153,2	164,9	176,7	188,5	200,3	212,1	213,4	213,4	213,4	213,4	213,4
28	-	-	-	-	-	-	-	-	-	-	-	125,3	131,9	145,1	158,3	171,5	184,7	197,9	211,1	224,3	237,5	250,7	263,9	263,9	263,9	267,7
30	-	-	-	-	-	-	-	-	-	-	-	-	-	-	140,0	152,7	165,4	178,1	190,9	203,6	216,3	229,0	241,7	254,5	254,5	307,3
32	-	-	-	-	-	-	-	-	-	-	-	-	-	-	-	162,9	176,4	190,0	203,6	217,1	230,7	244,3	257,9	271,4	271,4	349,7

ANCHORAGES – DESIGN RESISTANCE – CONCRETE C20/25, NOMINAL YIELD STRENGTH FOR TENSION - $f_{yk} = 600$ [N/mm ²]																										
$\frac{l_{bd}}{d_s}$	d_s [mm]	100	120	140	160	180	200	230	260	290	320	350	400	450	500	550	600	650	700	750	800	850	900	950	1000	Steel failure
		8	-	-	8,1	9,2	10,4	11,6	13,3	15,0	16,8	18,5	20,2	23,1	-	-	-	-	-	-	-	-	-	-	-	-
10	-	-	-	-	13,0	14,5	16,6	18,8	21,0	23,1	25,3	28,9	32,5	36,1	-	-	-	-	-	-	-	-	-	-	-	41,0
12	-	-	-	-	-	-	19,9	22,5	25,1	27,7	30,3	34,7	39,0	43,4	47,7	52,0	-	-	-	-	-	-	-	-	-	59,0
14	-	-	-	-	-	-	-	26,3	29,3	32,4	35,4	40,5	45,5	50,6	55,6	60,7	65,8	70,8	-	-	-	-	-	-	-	80,3
16	-	-	-	-	-	-	-	-	33,5	37,0	40,5	46,2	52,0	57,8	63,6	69,4	75,1	80,9	86,7	92,5	-	-	-	-	-	104,9
20	-	-	-	-	-	-	-	-	-	-	50,6	57,8	65,0	72,3	79,5	86,7	93,9	101,2	108,4	115,6	122,8	130,1	137,3	144,5	163,9	
25	-	-	-	-	-	-	-	-	-	-	-	-	81,3	90,3	99,4	108,4	117,4	126,4	135,5	144,5	153,5	162,6	171,6	180,6	256,1	
28	-	-	-	-	-	-	-	-	-	-	-	-	-	101,2	111,3	121,4	131,5	141,6	151,7	161,9	172,0	182,1	192,2	202,3	321,3	
30	-	-	-	-	-	-	-	-	-	-	-	-	-	-	-	119,2	130,1	140,9	151,7	162,6	173,4	184,3	195,1	205,9	368,8	
32	-	-	-	-	-	-	-	-	-	-	-	-	-	-	-	127,2	138,7	150,3	161,9	173,4	185,0	196,5	208,1	219,7	419,6	

ANCHORAGES – DESIGN RESISTANCE – CONCRETE C50/60, NOMINAL YIELD STRENGTH FOR TENSION - $f_{yk} = 600$ [N/mm ²]																										
$\frac{l_{bd}}{d_s}$	d_s [mm]	100	120	140	160	180	200	230	260	290	320	350	400	450	500	550	600	650	700	750	800	850	900	950	1000	Steel failure
		8	10,8	13,0	15,1	17,3	19,5	21,6	24,9	26,2	26,2	26,2	26,2	-	-	-	-	-	-	-	-	-	-	-	-	-
10	13,5	16,2	18,9	21,6	24,3	27,0	31,1	35,1	39,2	41,0	41,0	41,0	41,0	41,0	-	-	-	-	-	-	-	-	-	-	-	41,0
12	-	19,5	22,7	25,9	29,2	32,4	37,3	42,1	47,0	51,9	56,7	59,0	59,0	59,0	59,0	59,0	-	-	-	-	-	-	-	-	-	59,0
14	-	-	26,5	30,3	34,0	37,8	43,5	49,2	54,8	60,5	66,2	75,6	80,3	80,3	80,3	80,3	80,3	80,3	-	-	-	-	-	-	-	80,3
16	-	-	-	32,2	36,2	40,2	46,2	52,3	58,3	64,3	70,4	80,4	90,5	100,5	104,9	104,9	104,9	104,9	104,9	104,9	104,9	-	-	-	-	104,9
20	-	-	-	-	-	-	53,5	60,4	67,4	74,4	81,4	93,0	104,6	116,2	127,9	139,5	151,1	162,7	163,9	163,9	163,9	163,9	163,9	163,9	163,9	163,9
25	-	-	-	-	-	-	-	-	-	82,5	94,2	106,0	117,8	129,6	141,4	153,2	164,9	176,7	188,5	200,3	212,1	223,8	235,6	247,4	256,1	
28	-	-	-	-	-	-	-	-	-	-	105,6	118,8	131,9	145,1	158,3	171,5	184,7	197,9	211,1	224,3	237,5	250,7	263,9	277,1	321,3	
30	-	-	-	-	-	-	-	-	-	-	-	-	114,5	127,2	140,0	152,7	165,4	178,1	190,9	203,6	216,3	229,0	241,7	254,5	368,8	
32	-	-	-	-	-	-	-	-	-	-	-	-	-	-	135,7	149,3	162,9	176,4	190,0	203,6	217,1	230,7	244,3	257,9	419,6	

Basic performance data (cont.)

OVERLAP SPLICE – DESIGN RESISTANCE – CONCRETE C20/25, NOMINAL YIELD STRENGTH FOR TENSION - $f_{yk} = 600$ [N/mm ²]																									
$\frac{l_{bd}}{d_s}$	100	220	240	260	280	300	325	350	375	400	425	450	475	500	550	600	650	700	750	800	850	900	950	1000	Steel failure
8	-	12,7	13,9	15,0	16,2	17,3	18,8	20,2	21,7	23,1	-	-	-	-	-	-	-	-	-	-	-	-	-	-	26,2
10	-	-	-	18,8	20,2	21,7	23,5	25,3	27,1	28,9	30,7	32,5	34,3	36,1	-	-	-	-	-	-	-	-	-	-	41,0
12	-	-	-	-	-	-	28,2	30,3	32,5	34,7	36,9	39,0	41,2	43,4	47,7	52,0	-	-	-	-	-	-	-	-	59,0
14	-	-	-	-	-	-	-	-	37,9	40,5	43,0	45,5	48,1	50,6	55,6	60,7	65,8	70,8	-	-	-	-	-	-	80,3
16	-	-	-	-	-	-	-	-	-	49,1	52,0	54,9	57,8	63,6	69,4	75,1	80,9	86,7	92,5	-	-	-	-	-	104,9
20	-	-	-	-	-	-	-	-	-	-	-	-	-	-	79,5	86,7	93,9	101,2	108,4	115,6	122,8	130,1	137,3	144,5	163,9
25	-	-	-	-	-	-	-	-	-	-	-	-	-	-	-	-	117,4	126,4	135,5	144,5	153,5	162,6	171,6	180,6	256,1
28	-	-	-	-	-	-	-	-	-	-	-	-	-	-	-	-	-	-	151,7	161,9	172,0	182,1	192,2	202,3	321,3
30	-	-	-	-	-	-	-	-	-	-	-	-	-	-	-	-	-	-	-	173,4	184,3	195,1	205,9	216,8	368,8
32	-	-	-	-	-	-	-	-	-	-	-	-	-	-	-	-	-	-	-	-	196,5	208,1	219,7	231,2	419,6

OVERLAP SPLICE – DESIGN RESISTANCE – CONCRETE C50/60, NOMINAL YIELD STRENGTH FOR TENSION - $f_{yk} = 600$ [N/mm ²]																									
$\frac{l_{bd}}{d_s}$	200	220	240	260	280	300	325	350	375	400	425	450	475	500	550	600	650	700	750	800	850	900	950	1000	Steel failure
8	21,6	23,8	25,9	26,2	26,2	26,2	26,2	26,2	26,2	26,2	-	-	-	-	-	-	-	-	-	-	-	-	-	-	26,2
10	27,0	29,7	32,4	35,1	37,8	40,5	41,0	41,0	41,0	41,0	41,0	41,0	41,0	41,0	-	-	-	-	-	-	-	-	-	-	41,0
12	32,4	35,7	38,9	42,1	45,4	48,6	52,7	56,7	59,0	59,0	59,0	59,0	59,0	59,0	59,0	-	-	-	-	-	-	-	-	-	59,0
14	-	41,6	45,4	49,2	53,0	56,7	61,5	66,2	70,9	75,6	80,3	80,3	80,3	80,3	80,3	80,3	80,3	80,3	-	-	-	-	-	-	80,3
16	-	-	48,3	52,3	56,3	60,3	65,3	70,4	75,4	80,4	85,5	90,5	95,5	100,5	104,9	104,9	104,9	104,9	104,9	104,9	-	-	-	-	104,9
20	-	-	-	-	-	-	75,6	81,4	87,2	93,0	98,8	104,6	110,4	116,2	127,9	139,5	151,1	162,7	163,9	163,9	163,9	163,9	163,9	163,9	163,9
25	-	-	-	-	-	-	-	-	-	-	-	-	-	117,8	129,6	141,4	153,2	164,9	176,7	188,5	200,3	212,1	223,8	235,6	256,1
28	-	-	-	-	-	-	-	-	-	-	-	-	-	-	145,1	158,3	171,5	184,7	197,9	211,1	224,3	237,5	250,7	263,9	321,3
30	-	-	-	-	-	-	-	-	-	-	-	-	-	-	-	-	-	178,1	190,9	203,6	216,3	229,0	241,7	254,5	368,8
32	-	-	-	-	-	-	-	-	-	-	-	-	-	-	-	-	-	190,0	203,6	217,1	230,7	244,3	257,9	271,4	419,6

Product commercial data

Product Code	Volume [ml]	Quantity [pcs]			Weight [kg]			Bar Codes
		Box	Outer	Pallet	Box	Outer	Pallet	
R-KER-300	300	10	10	840	6.3	6.3	559.2	5906675075167
R-KER-345	345	10	10	840	7.1	7.1	623.3	5906675291086
R-KER-400	400	10	10	560	8.1	8.1	483.8	5906675329444
R-KER-300-W	300	10	10	840	6.3	6.3	559.2	5906675432021
R-KER-380-W	380	10	10	560	8.2	8.2	486.6	5906675222981
R-KER-400-S	400	10	10	560	8.2	8.2	489.2	5906675380452

R-KEM II with Threaded Rods for Concrete

Universal polyester (styrene free) resin - European Approval for 15 substrates



Installation movie



Approvals and Reports

- ETA-12/039



Product overview

Features and benefits

- The most convenient bonded anchor for general purpose use
- Quick, secure and simple installation
- Product with wide spectrum of use in the medium load capacity area
- Ideal for applications where mechanical anchors are not suitable
- Suitable for multiple use. Partly used product can be reused after fitting spare nozzle

Applications

- Consoles
- Staircases
- Gates
- High racking
- Canopies
- Sanitary appliances
- Steel constructions
- Railings
- Handrails
- Ladders
- Cable trays

Base materials

Approved for use in:

- Non-cracked concrete C20/25-C50/60

Also suitable for use in:

- Natural Stone (after site testing)

Installation guide

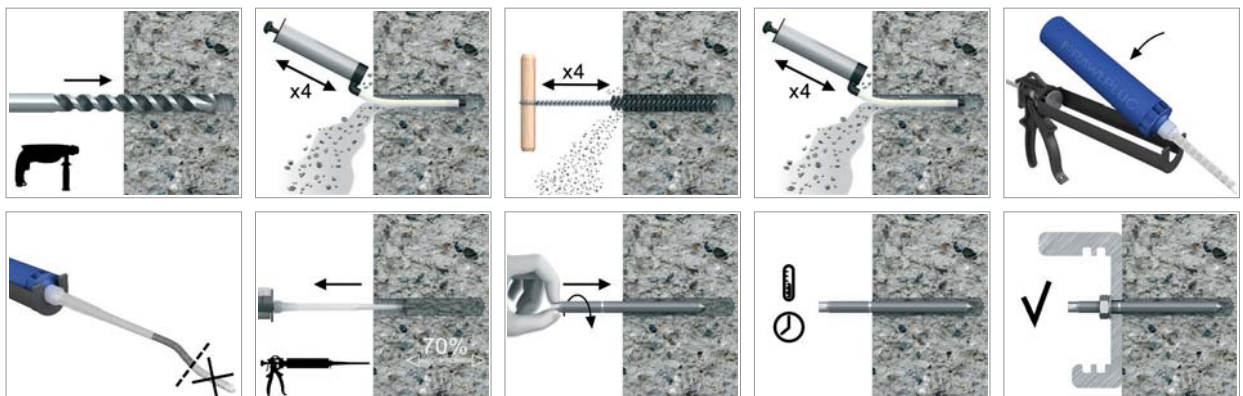

Installation guide (cont.)

1. Drill hole to the required diameter and depth for stud size being used.
2. Solid substrates: Clean the drill hole thoroughly with brush and hand pump at least four times before installation.
3. Attach nozzle and insert cartridge into gun.
4. Dispense to waste until even colour is obtained.
5. Insert the mixer nozzle to the bottom of the drill hole and inject resin, slowly withdrawing the nozzle as the hole is filled to 70% of its depth.
6. Immediately insert the stud, slowly and with slight twisting motion. Remove any excess resin around the hole before it sets and leave it undisturbed until the curing time elapses.
7. Attach fixture and tighten the nut to the required torque.

Product information

Product Code	Resin	Description / Resin Type	Volume
			[ml]
R-KEM-II-175	R-KEMII	Styrene Free Polyester Resin	175
R-KEM-II-300			300
R-KEM-II-380			380
R-KEM-II-410			410
R-KEM-II-175-W	R-KEMII-W	Low Temperature (Winter) / Rapid Cure Styrene Free Polyester Resin	175
R-KEM-II-300-W			300
R-KEM-II-175-S	R-KEMII-S	High Temperature (Summer) / Slow Cure Styrene Free Polyester Resin	175
R-KEM-II-300-S			300
R-KEM-II-175-SET	R-KEMII-SET	Set with 4 studs and plastic sleeves	175
R-KEM-II-300-SET			300
R-KEM-II-300-STONE	R-KEMII-STONE	Stone colour Styrene Free Polyester Resin	410
R-KEM-II-410-STONE			410
R-KEM-II-300-GREY	R-KEMII-GREY	Grey colour Styrene Free Polyester Resin	300
R-KEM-II-410-GREY			410

R-STUDS

Size	Product Code			Anchor		Fixture
	Steel class 5.8	Steel class 8.8	Steel grade A4	Diameter	Length	Hole diameter
				d	L	d _f
			[mm]	[mm]	[mm]	
M8	R-STUDS-08110	R-STUDS-08110-88	R-STUDS-08110-A4	8	110	9
	R-STUDS-08160	-	R-STUDS-08160-A4	8	160	9
M10	R-STUDS-10130	R-STUDS-10130-88	R-STUDS-10130-A4	10	130	12
	R-STUDS-10170	-	R-STUDS-10170-A4	10	170	12
	R-STUDS-10190	-	R-STUDS-10190-A4	10	190	12
M12	R-STUDS-12160	R-STUDS-12160-88	R-STUDS-12160-A4	12	160	14
	R-STUDS-12190	-	R-STUDS-12190-A4	12	190	14
	R-STUDS-12220	-	R-STUDS-12220-A4	12	220	14
	R-STUDS-12260	-	R-STUDS-12260-A4	12	260	14
	R-STUDS-12300	-	R-STUDS-12300-A4	12	300	14
M16	R-STUDS-16190	R-STUDS-16190-88	R-STUDS-16190-A4	16	190	18
	R-STUDS-16220	-	R-STUDS-16220-A4	16	220	18
	R-STUDS-16260	-	R-STUDS-16260-A4	16	260	18
	R-STUDS-16300	-	R-STUDS-16300-A4	16	300	18
	R-STUDS-16380	-	R-STUDS-16380-A4	16	380	18
M20	R-STUDS-20260	R-STUDS-20260-88	R-STUDS-20260-A4	20	260	22
	R-STUDS-20300	-	R-STUDS-20300-A4	20	300	22
	R-STUDS-20350	-	R-STUDS-20350-A4	20	350	22
M24	R-STUDS-24300	R-STUDS-24300-88	R-STUDS-24300-A4	24	300	26
M30	R-STUDS-30380	R-STUDS-30380-88	R-STUDS-30380-A4	30	380	32

* Make to order

All products listed in this publication are branded and distributed with RAWLPLUG® or RAWL® trademarks.

Installation data

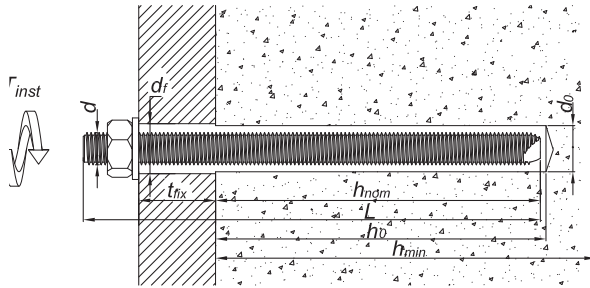

R-STUDS

Size			M8	M10	M12	M16	M20	M24	M30
Thread diameter	d	[mm]	8	10	12	16	20	24	30
Hole diameter in substrate	d ₀	[mm]	10	12	14	18	24	28	35
Hole diameter in fixture	d _f	[mm]	9	12	14	18	24	28	35
Min. hole depth in substrate	h ₀	[mm]	h _{nom} + 5	h _{nom} + 5	h _{nom} + 5	h _{nom} + 5	h _{nom} + 5	h _{nom} + 5	h _{nom} + 5
Min. substrate thickness	h _{min}	[mm]	h _{nom} + 2d ₀ ≥ 100	h _{nom} + 2d ₀ ≥ 100	h _{nom} + 2d ₀ ≥ 100	h _{nom} + 2d ₀ ≥ 100	h _{nom} + 2d ₀ ≥ 100	h _{nom} + 2d ₀ ≥ 100	h _{nom} + 2d ₀ ≥ 100
Installation torque	T _{inst}	[Nm]	10	20	40	80	120	180	300
Min. spacing	s _{min}	[mm]	0.5 * h _{nom} ≥ 40	0.5 * h _{nom} ≥ 40	0.5 * h _{nom} ≥ 40	0.5 * h _{nom} ≥ 40	0.5 * h _{nom} ≥ 40	0.5 * h _{nom} ≥ 40	0.5 * h _{nom} ≥ 40
Min. edge distance	c _{min}	[mm]	0.5 * h _{nom} ≥ 40	0.5 * h _{nom} ≥ 40	0.5 * h _{nom} ≥ 40	0.5 * h _{nom} ≥ 40	0.5 * h _{nom} ≥ 40	0.5 * h _{nom} ≥ 40	0.5 * h _{nom} ≥ 40
MINIMUM EMBEDMENT DEPTH									
Installation depth	h _{nom, min}	[mm]	60	70	80	100	120	140	165
MAXIMUM EMBEDMENT DEPTH									
Installation depth	h _{nom, max}	[mm]	100	120	145	190	240	290	360

Minimum working and curing time

Resin temperature [°C]	Concrete temperature [°C]	Working time [min]			Curing time* [min]		
		R-KEMII-S	R-KEMII	R-KEMII-W	R-KEMII-S	R-KEMII	R-KEMII-W
5	-20	-	-	45	-	-	24h
5	-15	-	-	30	-	-	18h
5	-10	-	-	20	-	-	8h
5	-5	3h	70	11	24h	8h	5h
5	0	2h	45	7	18h	4h	2h
5	5	1h	25	5	12h	2h	1h
10	10	45	15	2	8h	90	45
15	15	25	9	1,5	6h	60	30
20	20	15	5	1	4h	45	15
25	30	7	2	-	1.5h	30	-
25	35	6	-	-	1h	-	-
25	40	5	-	-	45	-	-

*For wet concrete the curing time must be doubled

Mechanical properties

Size			M8	M10	M12	M16	M20	M24	M30
R-STUDS METRIC THREADED RODS - steel class 5.8									
Nominal ultimate tensile strength - tension	f_{uk}	[N/mm ²]	500	500	500	500	500	500	500
Nominal yield strength - tension	f_{yk}	[N/mm ²]	400	400	400	400	400	400	400
Cross sectional area - tension	A_s	[mm ²]	36.6	58	84.3	157	245	352.8	559.8
Elastic section modulus	W_{el}	[mm ³]	31.2	62.3	109.2	277.5	541	935	1868
Characteristic bending resistance	$M_{Rk,s}^0$	[Nm]	19	37	65	166	324	561	1124
Design bending resistance	M	[Nm]	15	30	52	133	259	449	899
Allowable bending resistance	M_{rec}	[Nm]	11	21	37	95	185	321	642
R-STUDS METRIC THREADED RODS - steel class 8.8									
Nominal ultimate tensile strength - tension	f_{uk}	[N/mm ²]	800	800	800	800	800	800	800
Nominal yield strength - tension	f_{yk}	[N/mm ²]	640	640	640	640	640	640	640
Cross sectional area - tension	A_s	[mm ²]	36.6	58	84.3	157	245	352.8	559.8
Elastic section modulus	W_{el}	[mm ³]	31.2	62.3	109.2	277.5	541	935	1868
Characteristic bending resistance	$M_{Rk,s}^0$	[Nm]	30	60	105	266	519	898	1799
Design bending resistance	M	[Nm]	24	48	84	213	416	718	1439
Allowable bending resistance	M_{rec}	[Nm]	17	34	60	152	297	513	1028
R-STUDS METRIC THREADED RODS - A4									
Nominal ultimate tensile strength - tension	f_{uk}	[N/mm ²]	700	700	700	700	700	700	700
Nominal yield strength - tension	f_{yk}	[N/mm ²]	350	350	350	350	350	350	350
Cross sectional area - tension	A_s	[mm ²]	36.6	58	84.3	157	245	352.8	559.8
Elastic section modulus	W_{el}	[mm ³]	31.2	62.3	109.2	277.5	541	935	1868
Characteristic bending resistance	$M_{Rk,s}^0$	[Nm]	26	52	92	233	454	786	1574
Design bending resistance	M	[Nm]	17	34	59	149	291	504	1009
Allowable bending resistance	M_{rec}	[Nm]	12	24	42	107	208	360	721

Basic performance data

R-STUDS

Performance data for single anchor without influence of edge distance and spacing

CHARACTERISTIC LOAD									
TENSION LOAD N_{Rk}									
R-STUDS METRIC THREADED RODS - STEEL CLASS 5.8									
Minimum embedment depth	[kN]	14.3	20.9	27.1	40.2	60.3	68.6	85.5	
Maximum embedment depth	[kN]	18.0	29.0	42.0	76.4	120.6	142.1	186.6	
R-STUDS METRIC THREADED RODS - STEEL CLASS 8.8									
Minimum embedment depth	[kN]	14.3	20.9	27.1	40.2	60.3	68.6	85.5	
Maximum embedment depth	[kN]	23.9	35.8	49.2	76.4	120.6	142.1	186.6	
R-STUDS METRIC THREADED RODS - A4									
Minimum embedment depth	[kN]	14.3	20.9	27.1	40.2	60.3	68.6	85.5	
Maximum embedment depth	[kN]	23.9	35.8	49.2	76.4	120.6	142.1	186.6	
SHEAR LOAD V_{Rk}									
R-STUDS METRIC THREADED RODS - STEEL CLASS 5.8									
Minimum embedment depth	[kN]	9.00	14.0	21.0	39.0	61.0	88.0	140.0	
Maximum embedment depth	[kN]	9.00	14.0	21.0	39.0	61.0	88.0	140.0	
R-STUDS METRIC THREADED RODS - STEEL CLASS 8.8									
Minimum embedment depth	[kN]	15.0	23.0	34.0	63.0	98.0	137.2	171.1	
Maximum embedment depth	[kN]	15.0	23.0	34.0	63.0	98.0	141.0	224.0	
R-STUDS METRIC THREADED RODS - A4									
Minimum embedment depth	[kN]	13.0	20.0	29.0	86.0	86.0	124.0	171.1	
Maximum embedment depth	[kN]	13.0	20.0	29.0	86.0	86.0	124.0	196.0	

Basic performance data (cont.)

R-STUDS

Performance data for single anchor without influence of edge distance and spacing

DESIGN LOAD								
TENSION LOAD N_{Rd}								
R-STUDS METRIC THREADED RODS - STEEL CLASS 5.8								
Minimum embedment depth	[kN]	6.82	11.6	15.1	22.3	33.5	38.1	47.5
Maximum embedment depth	[kN]	11.4	19.3	27.3	42.5	67.0	79.0	103.7
R-STUDS METRIC THREADED RODS - STEEL CLASS 8.8								
Minimum embedment depth	[kN]	6.82	11.6	15.1	22.3	33.5	38.1	47.5
Maximum embedment depth	[kN]	11.4	19.9	27.3	42.5	67.0	79.0	103.7
R-STUDS METRIC THREADED RODS - A4								
Minimum embedment depth	[kN]	6.82	11.6	15.1	22.3	33.5	38.1	47.5
Maximum embedment depth	[kN]	11.4	19.9	27.3	42.5	67.0	79.0	103.7
SHEAR LOAD V_{Rd}								
R-STUDS METRIC THREADED RODS - STEEL CLASS 5.8								
Minimum embedment depth	[kN]	7.20	11.2	16.8	31.2	48.8	70.4	112.0
Maximum embedment depth	[kN]	7.20	11.2	16.8	31.2	48.8	70.4	112.0
R-STUDS METRIC THREADED RODS - STEEL CLASS 8.8								
Minimum embedment depth	[kN]	12.0	18.4	27.2	50.4	78.4	91.5	114.0
Maximum embedment depth	[kN]	12.0	18.4	27.2	50.4	78.4	112.8	179.2
R-STUDS METRIC THREADED RODS - A4								
Minimum embedment depth	[kN]	8.33	12.8	18.6	55.1	55.1	79.5	114.0
Maximum embedment depth	[kN]	8.33	12.8	18.6	55.1	55.1	79.5	125.6
RECOMMENDED LOAD								
TENSION LOAD N_{rec}								
R-STUDS METRIC THREADED RODS - STEEL CLASS 5.8								
Minimum embedment depth	[kN]	4.87	8.29	10.8	16.0	23.9	27.2	33.9
Maximum embedment depth	[kN]	8.12	13.8	19.5	30.3	47.9	56.4	74.1
R-STUDS METRIC THREADED RODS - STEEL CLASS 8.8								
Minimum embedment depth	[kN]	4.87	8.29	10.8	16.0	23.9	27.2	33.9
Maximum embedment depth	[kN]	8.12	14.2	19.5	30.3	47.9	56.4	74.1
R-STUDS METRIC THREADED RODS - A4								
Minimum embedment depth	[kN]	4.87	8.29	10.8	16.0	23.9	27.2	33.9
Maximum embedment depth	[kN]	8.12	14.2	19.5	30.3	47.9	56.4	74.1
SHEAR LOAD V_{rec}								
R-STUDS METRIC THREADED RODS - STEEL CLASS 5.8								
Minimum embedment depth	[kN]	5.14	8.00	12.0	22.3	34.9	50.3	80.0
Maximum embedment depth	[kN]	5.14	8.00	12.0	22.3	34.9	50.3	80.0
R-STUDS METRIC THREADED RODS - STEEL CLASS 8.8								
Minimum embedment depth	[kN]	8.57	13.1	19.4	36.0	56.0	65.4	81.5
Maximum embedment depth	[kN]	8.57	13.1	19.4	36.0	56.0	80.6	128.0
R-STUDS METRIC THREADED RODS - A4								
Minimum embedment depth	[kN]	5.95	9.16	13.3	39.4	39.4	56.8	81.5
Maximum embedment depth	[kN]	5.95	9.16	13.3	39.4	39.4	56.8	89.7

Product commercial data

Product Code	Volume [ml]	Quantity [pcs]			Weight [kg]			Bar Codes
		Box	Outer	Pallet	Box	Outer	Pallet	
R-KEM-II-175 ¹⁾	175	10	50	600	3.8	18.9	257.2	5906675050249
R-KEM-II-300 ¹⁾	300	10	10	840	5.9	5.9	529.0	5906675050256
R-KEM-II-380 ¹⁾	380	10	10	560	8.2	8.2	486.3	5906675097770
R-KEM-II-410 ¹⁾	410	10	10	560	8.4	8.4	498.7	5906675408163
R-KEM-II-175-W ¹⁾	175	10	50	600	3.8	19.2	260.6	5906675064659
R-KEM-II-300-W ¹⁾	300	10	50	600	5.9	29.6	385.1	5906675064666
R-KEM-II-175-S ¹⁾	175	10	50	600	6.0	30.0	390.0	5906675064635
R-KEM-II-300-S ¹⁾	300	10	50	600	6.0	30.0	390.0	5906675064642
R-KEM-II-175-SET ¹⁾	175	5	5	525	3.0	3.0	348.3	5906675057866
R-KEM-II-300-SET ¹⁾	300	5	5	320	4.9	4.9	345.9	5906675057859
R-KEM-II-300-STONE ¹⁾	300	10	50	600	6.0	30.0	390.0	5906675038124
R-KEM-II-410-STONE ¹⁾	410	10	10	560	8.4	8.4	498.7	5906675424958
R-KEM-II-300-GREY ¹⁾	300	10	50	600	6.0	30.0	390.0	5906675038131
R-KEM-II-410-GREY ¹⁾	410	10	10	560	8.4	8.4	498.7	5906675424941

1) ETA-12/0394

R-KEM II with Threaded Rods for Masonry

Universal polyester (styrene free) resin - European Approval for 15 substrates



Installation movie



Approvals and Reports

- ETA-12/0528



Product overview

Features and benefits

- The most convenient bonded anchor for general purpose use
- Approved for 15 substrates
- Quick, secure and simple installation
- Product with wide spectrum of use in the medium load capacity area
- Ideal for applications where mechanical anchors are not suitable
- Easy dosage thanks to patented self-opening system and use of manual or pneumatic gun
- Option of using standard manual silicone gun
- Suitable for multiple use. Partly used product can be reused after fitting spare nozzle

Applications

- Gates
- Window elements
- Canopies
- Sanitary appliances
- Railings
- Handrails
- Consoles
- Ladders
- Cable trays

Base materials

Approved for use in:

- Solid Brick
- Solid Sand-lime Brick
- Hollow Sand-lime Brick
- Hollow Brick
- Hollow Lightweight Concrete Block
- Aerated Concrete Block

Installation guide



Installation guide (cont.)

1. Drill hole to the required diameter and depth for stud size being used.
- 2a. Solid substrates: Clean the drill hole thoroughly with brush and hand pump at least four times before installation.
- 2b. Hollow substrates: Insert mesh sleeve into the hole.
3. Attach nozzle and insert cartridge into gun.
4. Dispense to waste until even colour is obtained.
- 5a. Solid Substrates: Insert the mixer nozzle to the bottom of the drill hole and inject resin,, slowly withdrawing the nozzle as the hole is filled to 70% of its depth.
- 5b. Hollow substrate: Insert the mixer nozzle to the bottom of the drill hole and inject resin, slowly withdrawing the nozzle as the hole is filled to the surface.
6. Immediately insert the stud, slowly and with slight twisting motion. Remove any excess resin around the hole before it sets and leave it undisturbed until the curing time elapses.
7. Attach fixture and tighten the nut to the required torque.

Product information

Product Code	Resin	Description / Resin Type	Volume
			[m]
R-KEM-II-175	R-KEMII	Styrene Free Polyester Resin	175
R-KEM-II-300			300
R-KEM-II-410			410
R-KEM-II-175-W	R-KEMII-W	Low Temperature (Winter) / Rapid Cure Styrene Free Polyester Resin	175
R-KEM-II-300-W			300
R-KEM-II-175-S	R-KEMII-S	High Temperature (Summer) / Slow Cure Styrene Free Polyester Resin	175
R-KEM-II-300-S			300
R-KEM-II-175-SET	R-KEMII-SET	Set with 4 studs and plastic sleeves	175
R-KEM-II-300-SET			300
R-KEM-II-300-STONE	R-KEMII-STONE	Stone colour Styrene Free Polyester Resin	300
R-KEM-II-410-STONE			410
R-KEM-II-300-GREY	R-KEMII-GREY	Grey colour Styrene Free Polyester Resin	300
R-KEM-II-410-GREY			410

R-STUDS

Size	Product Code			Anchor		Fixture							
	Steel class 5.8	Steel class 8.8	Steel grade A4	Diameter	Length	Hole diameter	Max. thickness Solid substrates	Max. thickness Hollow substrates		Max. thickness t_{fix} for: R-STUDS		Max. thickness t_{fix} for: R-STUDS_MIX	
				d	L	d_f	t_{fix} Standard	t_{fix} Standard	t_{fix} Maximum	$h_{nom, min}$	$h_{nom, max}$	$h_{nom, min}$	$h_{nom, max}$
				[mm]	[mm]	[mm]	[mm]	[mm]	[mm]	[mm]	[mm]	[mm]	[mm]
M8	R-STUDS-08110	R-STUDS-08110-88	R-STUDS-08110-A4	8	110	9	20	50	20	40	-	40	-
	R-STUDS-08160	-	R-STUDS-08160-A4	8	160	9	70	100	70	90	-	90	-
M10	R-STUDS-10130	R-STUDS-10130-88	R-STUDS-10130-A4	10	130	12	33	33	-	58	-	48	-
	R-STUDS-10170	-	R-STUDS-10170-A4	10	170	12	73	73	33	98	-	88	-
	R-STUDS-10190	-	R-STUDS-10190-A4	10	190	12	93	93	53	118	-	108	-
M12	R-STUDS-12160	R-STUDS-12160-88	R-STUDS-12160-A4	12	160	14	50	60	20	85	-	65	-
	R-STUDS-12190	-	R-STUDS-12190-A4	12	190	14	80	90	50	115	-	95	-
	R-STUDS-12220	-	R-STUDS-12220-A4	12	220	14	110	120	80	145	-	125	-
	R-STUDS-12260	-	R-STUDS-12260-A4	12	260	14	150	160	120	185	-	165	-
	R-STUDS-12300	-	R-STUDS-12300-A4	12	300	14	190	200	160	225	45	205	45
M16	R-STUDS-16190	R-STUDS-16190-88	R-STUDS-16190-A4	16	190	18	66	86	-	111	-	71	-
	R-STUDS-16220	-	R-STUDS-16220-A4	16	220	18	96	116	-	141	-	101	-
	R-STUDS-16260	-	R-STUDS-16260-A4	16	260	18	136	156	-	181	-	141	-
	R-STUDS-16300	-	R-STUDS-16300-A4	16	300	18	176	196	-	221	-	181	-
	R-STUDS-16380	-	R-STUDS-16380-A4	16	380	18	256	276	-	301	41	261	41

Installation data

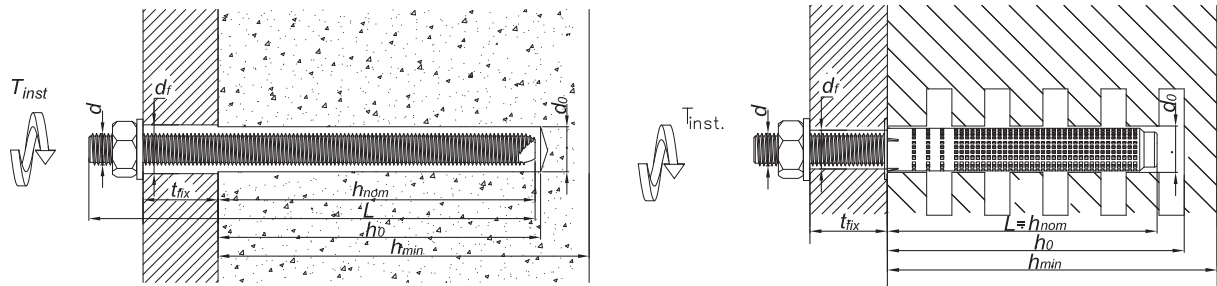

SOLID SUBSTRATES

Size			Mw8	M10	M12	M16	M8	M10	M12	M16
Substrate			Ceramic solid substrates				Aerated concrete			
Thread diameter	d	[mm]	8	10	12	16	8	10	12	16
Hole diameter in substrate	d ₀	[mm]	10	12	14	18	10	12	14	18
Installation torque	T _{inst}	[Nm]	3	8	6	10	5	8	10	15
Min. hole depth in substrate	h ₀	[mm]	h _{nom} + 5	h _{nom} + 5	h _{nom} + 5	h _{nom} + 5	h _{nom} + 5	h _{nom} + 5	h _{nom} + 5	h _{nom} + 5
Installation depth	h _{nom,min}	[mm]	80	85	95	105	80	85	95	105
Min. spacing	s _{min}	[mm]	50	50	50	54	50	50	50	54
Min. edge distance	c _{min}	[mm]	50	50	50	54	50	50	50	54

HOLLOW SUBSTRATES

Size			M8	M10	M12	M16				
Plastic mesh sleeve size	d _{xl}		12x50	12x80	16x130	16x85	16x130	16x85	20x85	
Thread diameter	d	[mm]	8	8	10	10	12	12	16	
Hole diameter in substrate	d ₀	[mm]	12	12	16	16	16	16	20	
Installation torque	T _{inst}	[Nm]	3	3	4	4	6	6	10	
Min. hole depth in substrate	h ₀	[mm]	h _{nom} + 5	h _{nom} + 5	h _{nom} + 5	h _{nom} + 5	h _{nom} + 5	h _{nom} + 5	h _{nom} + 5	
Min. spacing	s _{min}	[mm]	100	100	100	100	100	100	120	
Min. edge distance	c _{min}	[mm]	100	100	100	100	100	100	120	
STANDARD EMBEDMENT DEPTH										
Installation depth	h _{nom,s}	[mm]	50	-	-	85	-	85	85	
MAXIMUM EMBEDMENT DEPTH										
Installation depth	h _{nom,max}	[mm]	-	80	125	-	125	-	-	

Installation data

Minimum working and curing time

Resin temperature [°C]	Concrete temperature [°C]	Working time [min]			Curing time* [min]		
		R-KEMII-S	R-KEMII	R-KEMII-W	R-KEMII-S	R-KEMII	R-KEMII-W
5	-20	-	-	45	-	-	24 h
5	-15	-	-	30	-	-	18 h
5	-10	-	-	20	-	-	8 h
5	-5	3 h	70	11	24 h	8 h	5 h
5	0	2 h	45	7	18 h	4 h	2 h
5	5	1 h	25	5	12 h	2 h	1 h
10	10	45	15	2	8 h	1.5 h	45
15	15	25	9	1.5	6 h	1 h	30
20	20	15	5	1	4 h	45	15
25	30	7	2	-	1.5 h	30	-
25	35	6	-	-	1 h	-	-
25	40	5	-	-	45	-	-

*For wet concrete the curing time must be doubled

Mechanical properties

R-STUDS

Size			M8	M10	M12	M16
R-STUDS Metric Threaded Rods - Steel Class 5.8						
Nominal ultimate tensile strength - tension	f_{uk}	[N/mm ²]	500	500	500	500
Nominal yield strength - tension	f_{yk}	[N/mm ²]	400	400	400	400
Cross sectional area - tension	A_s	[mm ²]	36.6	58	84.3	157
Elastic section modulus	W_{el}	[mm ³]	31.2	62.3	109.2	277.5
Characteristic bending resistance	$M_{Rk,s}^0$	[Nm]	19	37	65	166
Design bending resistance	M	[Nm]	15	30	52	133
Allowable bending resistance	M_{rec}	[Nm]	11	21	37	95
R-STUDS Metric Threaded Rods - Steel Class 8.8						
Nominal ultimate tensile strength - tension	f_{uk}	[N/mm ²]	800	800	800	800
Nominal yield strength - tension	f_{yk}	[N/mm ²]	640	640	640	640
Cross sectional area - tension	A_s	[mm ²]	36.6	58	84.3	157
Elastic section modulus	W_{el}	[mm ³]	31.2	62.3	109.2	277.5
Characteristic bending resistance	$M_{Rk,s}^0$	[Nm]	30	60	105	266
Design bending resistance	M	[Nm]	24	48	84	213
Allowable bending resistance	M_{rec}	[Nm]	17	34	60	152
R-STUDS Metric Threaded Rods - A4						
Nominal ultimate tensile strength - tension	f_{uk}	[N/mm ²]	700	700	700	700
Nominal yield strength - tension	f_{yk}	[N/mm ²]	350	350	350	350
Cross sectional area - tension	A_s	[mm ²]	36.6	58	84.3	157
Elastic section modulus	W_{el}	[mm ³]	31.2	62.3	109.2	277.5
Characteristic bending resistance	$M_{Rk,s}^0$	[Nm]	26	52	92	233
Design bending resistance	M	[Nm]	17	34	59	149
Allowable bending resistance	M_{rec}	[Nm]	12	24	42	107

Basic performance data

SOLID SUBSTRATES

Performance data for single anchor without influence of edge distance and spacing

Size			M8	M10	M12	M16
Substrate	Solid substrates					
CHARACTERISTIC LOAD*						
TENSION LOADS N_{Rk}						
Solid clay brick min 20 MPa (eg Mz20/2.0)	[kN]		6.00	7.00	7.00	7.00
Autoclaved aerated concrete block min 6.0 MPa (AAC7)	[kN]		1.50	2.00	2.50	3.00
Solid silicate brick min 20 MPa (eg KS NF 20/2.0)	[kN]		5.00	5.00	5.00	5.00

All products listed in this publication are branded and distributed with RAWLPLUG® or RAWL® trademarks.

Basic performance data (cont.)

SOLID SUBSTRATES

Performance data for single anchor without influence of edge distance and spacing

Size		M8	M10	M12	M16
SHEAR LOADS VRk					
Solid clay brick min 20 MPa (eg Mz20/2.0)	[kN]	3.50	5.00	7.00	7.00
Autoclaved aerated concrete block min 6.0 MPa (AAC7)	[kN]	1.50	2.00	2.50	2.50
Solid silicate brick min 20 MPa (eg KS NF 20/2.0)	[kN]	3.50	5.00	5.00	5.00
DESIGN LOAD					
TENSION LOAD N_{Rd}					
Solid clay brick min 20 MPa (eg Mz20/2.0)	[kN]	2.40	2.80	2.80	2.80
Autoclaved aerated concrete block min 6.0 MPa (AAC7)	[kN]	0.75	1.00	1.25	1.50
Solid silicate brick min 20 MPa (eg KS NF 20/2.0)	[kN]	2.00	2.00	2.00	2.00
SHEAR LOAD V_{Rd}					
Solid clay brick min 20 MPa (eg Mz20/2.0)	[kN]	1.40	2.00	2.80	2.80
Autoclaved aerated concrete block min 6.0 MPa (AAC7)	[kN]	0.75	1.00	1.25	1.25
Solid silicate brick min 20 MPa (eg KS NF 20/2.0)	[kN]	1.40	2.00	2.00	2.00
RECOMMENDED LOAD**					
TENSION LOAD N_{rec}					
Solid clay brick min 20 MPa (eg Mz20/2.0)	[kN]	1.71	2.00	2.00	2.00
Autoclaved aerated concrete block min 6.0 MPa (AAC7)	[kN]	0.54	0.71	0.89	1.07
Solid silicate brick min 20 MPa (eg KS NF 20/2.0)	[kN]	1.43	1.43	1.43	1.43
SHEAR LOAD V_{rec}					
Solid clay brick min 20 MPa (eg Mz20/2.0)	[kN]	1.00	1.43	2.00	2.00
Autoclaved aerated concrete block min 6.0 MPa (AAC7)	[kN]	0.54	0.71	0.89	0.89
Solid silicate brick min 20 MPa (eg KS NF 20/2.0)	[kN]	1.00	1.43	1.43	1.43

*According to ETAG 029, **Partial safety factor 1.4

Basic performance data

HOLLOW SUBSTRATES

Performance data for single anchor without influence of edge distance and spacing

Size		M8	M10	M12	M16			
Substrate		Hollow substrates						
Plastic mesh sleeve (dxl)	[mm]	12x50	12x80	15x85	15x125	15x85	15x125	20x85
CHARACTERISTIC LOAD								
TENSION AND SHEAR LOAD F_{Rk}								
Silicate hollow block min 12 MPa (eg KS Ratio Block 8 DF)	[kN]	2.50	2.50	2.50	3.50	3.00	3.00	3.00
Perforated ceramic blocks min 12 MPa (eg Proton Hz 12/0.9 DF)	[kN]	2.00	2.50	2.50	2.50	2.50	2.50	2.50
Perforated ceramic blocks min 15 MPa (eg Wienerberger Porotherm)	[kN]	1.50	2.00	2.00	2.50	2.50	2.50	2.50
Perforated ceramic blocks min 10 MPa (eg Leiter Thermopor)	[kN]	1.50	2.00	2.00	2.50	2.50	2.50	2.50
Perforated ceramic blocks min 15 MPa (eg MEGA MAX)	[kN]	2.00	2.50	2.50	2.50	2.50	2.50	2.50
Perforated ceramic blocks min 6.0 MPa (eg LS Tableau Mono Rect)	[kN]	0.90	0.90	1.50	2.00	2.00	2.00	1.20
Perforated ceramic blocks min 6.0 MPa (eg LS Tableau Rect)	[kN]	0.90	1.20	1.50	1.50	1.50	2.00	1.50
Perforated ceramic blocks min 6.0 MPa (eg LS Monomur)	[kN]	0.90	0.90	1.20	1.50	1.50	1.50	1.50
Perforated ceramic blocks min 6 MPa (eg SM BGV Thermo)	[kN]	0.90	0.90	1.50	1.50	1.50	1.50	1.50
Perforated ceramic blocks min 6.0 MPa (eg SM BGV Thermo Plus)	[kN]	0.90	1.20	0.90	0.90	1.20	1.50	1.20
Lightweight concrete hollow block min 2.0 MPa	[kN]	1.20	1.50	2.50	2.00	2.50	2.50	2.50

Basic performance data (cont.)

HOLLOW SUBSTRATES

Size		M8	M10	M12	M16			
DESIGN LOAD								
TENSION AND SHEAR LOADS F_{Rd}								
Silicate hollow block min 12 MPa (eg KS Ratio Block 8 DF)	[kN]	1.00	1.00	1.00	1.40	1.20	1.20	1.20
Perforated ceramic blocks min 12 MPa (eg Proton Hz 12/0.9 DF)	[kN]	0.88	1.00	1.20	1.40	1.40	1.60	1.60
Perforated ceramic blocks min 15 MPa (eg Wienerberger Porotherm)	[kN]	0.60	0.80	1.00	1.00	1.40	1.40	1.00
Perforated ceramic blocks min 10 MPa (eg Leiter Thermopor)	[kN]	0.60	0.80	0.80	1.00	1.00	1.40	1.20
Perforated ceramic blocks min 15 MPa (eg MEGA MAX)	[kN]	0.80	1.00	1.40	1.40	1.60	1.60	1.60
Perforated ceramic blocks min 6.0 MPa (eg LS Tableau Mono Rect)	[kN]	0.36	0.36	0.80	0.80	0.80	0.80	0.60
Perforated ceramic blocks min 6.0 MPa (eg LS Tableau Rect)	[kN]	0.48	0.48	0.60	0.60	0.80	0.80	0.60
Perforated ceramic blocks min 6.0 MPa (eg LS Monomur)	[kN]	0.36	0.36	0.60	0.60	0.60	0.60	0.60
Perforated ceramic blocks min 6 MPa (eg SM BGV Thermo)	[kN]	0.36	0.36	0.60	0.60	0.60	0.60	0.60
Perforated ceramic blocks min 6.0 MPa (eg SM BGV Thermo Plus)	[kN]	0.48	0.48	0.48	0.48	0.48	0.60	0.48
Lightweight concrete hollow block min 2.0 MPa	[kN]	0.48	0.60	1.00	1.00	1.00	1.40	1.40
RECOMMENDED LOAD								
TENSION AND SHEAR LOADS F_{rec}								
Silicate hollow block min 12 MPa (eg KS Ratio Block 8 DF)	[kN]	0.71	0.71	0.71	1.00	0.86	0.86	0.86
Perforated ceramic blocks min 12 MPa (eg Proton Hz 12/0.9 DF)	[kN]	0.63	0.71	0.86	1.00	1.00	1.14	1.14
Perforated ceramic blocks min 15 MPa (eg Wienerberger Porotherm)	[kN]	0.43	0.57	0.71	0.71	1.00	1.00	0.71
Perforated ceramic blocks min 10 MPa (eg Leiter Thermopor)	[kN]	0.43	0.57	0.57	0.71	0.71	1.00	0.86
Perforated ceramic blocks min 15 MPa (eg MEGA MAX)	[kN]	0.57	0.71	1.00	1.00	1.14	1.14	1.14
Perforated ceramic blocks min 6.0 MPa (eg LS Tableau Mono Rect)	[kN]	0.26	0.26	0.57	0.57	0.57	0.57	0.43
Perforated ceramic blocks min 6.0 MPa (eg LS Tableau Rect)	[kN]	0.34	0.34	0.43	0.43	0.57	0.57	0.43
Perforated ceramic blocks min 6.0 MPa (eg LS Monomur)	[kN]	0.26	0.26	0.43	0.43	0.43	0.43	0.43
Perforated ceramic blocks min 6 MPa (eg SM BGV Thermo)	[kN]	0.26	0.26	0.43	0.43	0.43	0.43	0.43
Perforated ceramic blocks min 6.0 MPa (eg SM BGV Thermo Plus)	[kN]	0.34	0.34	0.34	0.34	0.34	0.43	0.34
Lightweight concrete hollow block min 2.0 MPa	[kN]	0.34	0.43	0.71	0.71	0.71	1.00	1.00

Product commercial data

Product Code	Volume [m ³]	Quantity [pcs]			Weight [kg]			Bar Codes
		Box	Outer	Pallet	Box	Outer	Pallet	
R-KEM-II-175	175	10	50	600	3.8	18.9	257.2	5906675050249
R-KEM-II-300	300	10	10	840	5.9	5.9	529.0	5906675050256
R-KEM-II-410	410	10	10	560	8.4	8.4	498.7	5906675408163
R-KEM-II-175-W	175	10	50	600	3.8	19.2	260.6	5906675064659
R-KEM-II-300-W	300	10	50	600	5.9	29.6	385.1	5906675064666
R-KEM-II-175-S	175	10	50	600	6.0	30.0	390.0	5906675064635
R-KEM-II-300-S	300	10	50	600	6.0	30.0	390.0	5906675064642
R-KEM-II-175-SET	175	5	5	525	3.0	3.0	348.3	5906675057866
R-KEM-II-300-SET	300	5	5	320	4.9	4.9	345.9	5906675057859
R-KEM-II-300-STONE	300	10	50	600	6.0	30.0	390.0	5906675038124
R-KEM-II-410-STONE	410	10	10	560	8.4	8.4	498.7	5906675424958
R-KEM-II-300-GREY	300	10	50	600	6.0	30.0	390.0	5906675038131
R-KEM-II-410-GREY	410	10	10	560	8.4	8.4	498.7	5906675424941

R-KF2 with Threaded Rods

Economy polyester resin approved for use in non-cracked concrete

Approvals and Reports

- ETA-11/0141



Product overview

Features and benefits

- Economical fixings resin for medium duty load applications
- Can be used in damp conditions and underwater applications
- Wide range of steel studs with different lengths and diameters
- Small edge and spacing distances
- Suitable for repetitive use. Partly used product can be reused by fitting a new mixing nozzle

Applications

- Guard rails
- Handrails
- Canopies
- Masonry support
- Balustrading
- Cable trays
- Curtain walling
- Fencing & gates manufacturing and installation

Base materials

Approved for use in:

- Non-cracked concrete C20/25-C50/60

Installation guide

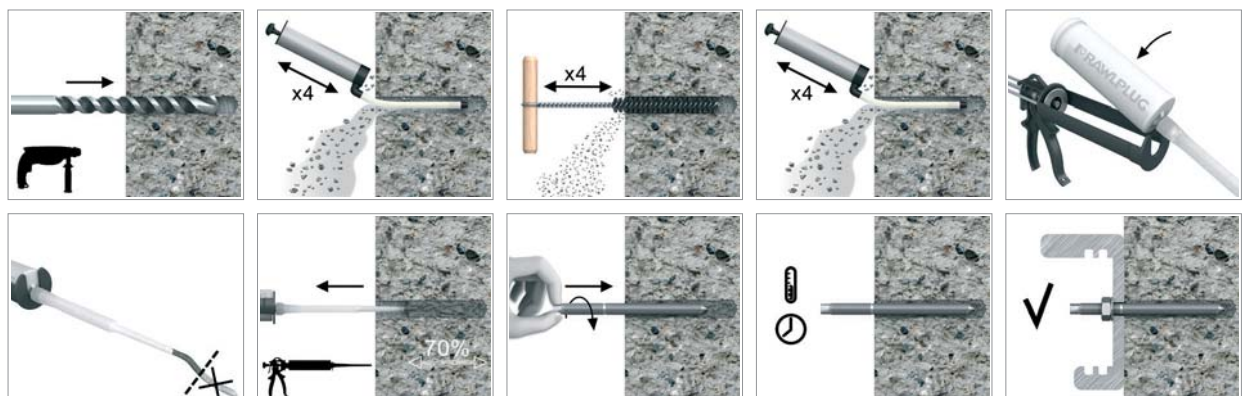

Installation guide (cont.)

1. Drill hole to the required diameter and depth for stud size being used.
2. Clean the drill hole thoroughly with brush and hand pump at least four times before installation.
3. Insert cartridge into gun and attach nozzle.
4. Dispense to waste until even colour is obtained.
5. Insert the mixer nozzle to the bottom of the drill hole and inject resin, slowly withdrawing the nozzle as the hole is filled to 70% of its depth.
6. Immediately insert the stud, slowly and with slight twisting motion. Remove any excess resin around the hole before it sets and leave it undisturbed until the curing time elapses.
7. Attach fixture and tighten the nut to the required torque.

Product information

Product Code	Resin	Description / Resin Type	Volume
			[ml]
R-KF2-300	R-KF2	Polyester Resin	300
R-KF2-345			345
R-KF2-380			380
R-KF2-400			400

R-STUDS

Size	Product Code			Anchor		Fixture		
	Steel class 5.8	Steel class 8.8	Steel grade A4	Diameter	Length	Hole diameter	Max. thickness	
				d	L	d _f	t _{fix} for h _{nom,min}	t _{fix} for h _{nom,max}
				[mm]	[mm]	[mm]	[mm]	[mm]
M8	R-STUDS-08110	R-STUDS-08110-88	R-STUDS-08110-A4	8	110	9	40	-
	R-STUDS-08160	-	R-STUDS-08160-A4*	8	160	9	90	50
M10	R-STUDS-10130	R-STUDS-10130-88	R-STUDS-10130-A4	10	130	12	48	-
	R-STUDS-10170	-	R-STUDS-10170-A4*	10	170	12	88	38
	R-STUDS-10190	-	R-STUDS-10190-A4*	10	190	12	108	58
M12	R-STUDS-12160	R-STUDS-12160-88	R-STUDS-12160-A4	12	160	14	65	-
	R-STUDS-12190	-	R-STUDS-12190-A4*	12	190	14	95	30
	R-STUDS-12220	-	R-STUDS-12220-A4*	12	220	14	125	60
	R-STUDS-12260	-	R-STUDS-12260-A4*	12	260	14	165	100
	R-STUDS-12300	-	R-STUDS-12300-A4*	12	300	14	205	140
M16	R-STUDS-16190	R-STUDS-16190-88	R-STUDS-16190-A4	16	190	18	71	-
	R-STUDS-16220	R-STUDS-16220-88	R-STUDS-16220-A4*	16	220	18	101	11
	R-STUDS-16260	-	R-STUDS-16260-A4*	16	260	18	141	51
	R-STUDS-16300	-	R-STUDS-16300-A4*	16	300	18	181	91
	R-STUDS-16380	-	R-STUDS-16380-A4*	16	380	18	261	171
M20	R-STUDS-20260	R-STUDS-20260-88	R-STUDS-20260-A4	20	260	22	117	-
	R-STUDS-20300	R-STUDS-20300-88	R-STUDS-20300-A4*	20	300	22	157	37
	R-STUDS-20350	-	R-STUDS-20350-A4*	20	350	22	207	87
M24	R-STUDS-24300	R-STUDS-24300-88	R-STUDS-24300-A4*	24	300	26	132	-
M30	R-STUDS-30380	R-STUDS-30380-88	R-STUDS-30380-A4	30	380	32	181	-

* Make to order

Installation data

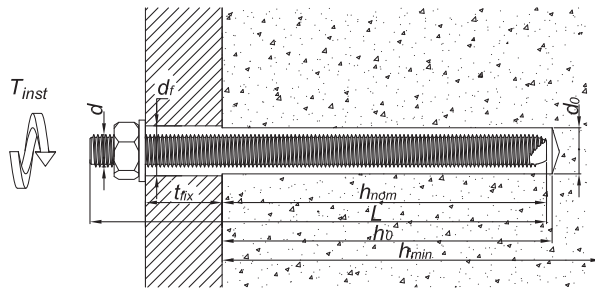

R-STUDS

Size			M8	M10	M12	M16	M20	M24	M30	
Thread diameter	d	[mm]	8	10	12	16	20	24	30	
Hole diameter in substrate	d ₀	[mm]	10	12	14	18	24	28	35	
Installation torque	T _{inst}	[Nm]	10	20	40	80	120	180	300	
Min. hole depth in substrate	h ₀	[mm]	h _{nom} + 5							
MINIMUM EMBEDMENT DEPTH										
Installation depth	h _{nom, min}	[mm]	60	70	80	100	120	140	165	
MAXIMUM EMBEDMENT DEPTH										
Installation depth	h _{nom, max}	[mm]	100	120	145	190	240	290	360	
Min. substrate thickness	h _{min}	[mm]	h _{nom} + 30 ≥ 100				h _{nom} + 2*d ₀			
Min. spacing	s _{min}	[mm]	0.5 * h _{nom} ≥ 40							
Min. edge distance	c _{min}	[mm]	0.5 * h _{nom} ≥ 40							

Minimum working and curing time

Resin temperature	Concrete temperature	Working time	Curing time*
[°C]	[°C]	[min]	[min]
5	-5	60	360
5	0	40	180
5	5	20	120
10	10	12	80
15	15	8	60
20	20	5	45
25	30	2	20

*For wet concrete the curing time must be doubled

Mechanical properties

R-STUDS

Size			M8	M10	M12	M16	M20	M24	M30
R-STUDS METRIC THREADED RODS - steel class 5.8									
Nominal ultimate tensile strength - tension	f _{uk}	[N/mm ²]	520	520	520	520	520	520	520
Nominal yield strength - tension	f _{yk}	[N/mm ²]	420	420	420	420	420	420	420
Cross sectional area - tension	A _s	[mm ²]	36.6	58	84.3	157	245	352.8	559.8
Elastic section modulus	W _{el}	[mm ³]	31.2	62.3	109.2	277.5	541	935	1868
Characteristic bending resistance	M ⁰ _{Bk,s}	[Nm]	20	39	68	173	338	583	1166
Design bending resistance	M	[Nm]	11	22	39	99	193	333	666
R-STUDS METRIC THREADED RODS - steel class 8.8									
Nominal ultimate tensile strength - tension	f _{uk}	[N/mm ²]	800	800	800	800	800	800	800
Nominal yield strength - tension	f _{yk}	[N/mm ²]	640	640	640	640	640	640	640
Cross sectional area - tension	A _s	[mm ²]	36.6	58	84.3	157	245	352.8	559.8
Elastic section modulus	W _{el}	[mm ³]	31.2	62.3	109.2	277.5	541	935	1868
Characteristic bending resistance	M ⁰ _{Bk,s}	[Nm]	30	60	105	266	519	898	1793
Design bending resistance	M	[Nm]	17	34	60	152	297	513	1025

Mechanical properties (cont.)

Size			M8	M10	M12	M16	M20	M24	M30
R-STUDS METRIC THREADED RODS - A4									
Nominal ultimate tensile strength - tension	f_{uk}	[N/mm ²]	700	700	700	700	700	700	700
Nominal yield strength - tension	f_{yk}	[N/mm ²]	350	350	350	350	350	350	350
Cross sectional area - tension	A_s	[mm ²]	36.6	58	84.3	157	245	352.8	559.8
Elastic section modulus	W_{el}	[mm ³]	31.2	62.3	109.2	277.5	541	935	1868
Characteristic bending resistance	$M_{Rk,s}^0$	[Nm]	26	52	92	233	454	785	1569
Design bending resistance	M	[Nm]	12	24	42	107	208	360	719

Basic performance data

R-STUDS

Performance data for single anchor without influence of edge distance and spacing

Size			M8	M10	M12	M16	M20	M24	M30
Substrate		Non-cracked concrete							
CHARACTERISTIC LOAD									
TENSION LOAD N_{Rk}									
R-STUDS METRIC THREADED RODS - STEEL CLASS 5.8									
Minimum embedment depth	[kN]	14.3	22	28.7	45.2	64.1	73.9	77.8	
Maximum embedment depth	[kN]	18	29	42	78	122	153.1	169.6	
R-STUDS METRIC THREADED RODS - STEEL CLASS 8.8									
Minimum embedment depth	[kN]	14.3	22	28.7	45.2	64.1	73.9	77.8	
Maximum embedment depth	[kN]	23.9	37.7	51.9	86	128.2	153.1	169.6	
R-STUDS METRIC THREADED RODS - A4									
Minimum embedment depth	[kN]	14.3	22	28.7	45.2	64.1	73.9	77.8	
Maximum embedment depth	[kN]	23.9	37.7	51.9	86	128.2	153.1	169.6	
SHEAR LOAD V_{Rk}									
R-STUDS METRIC THREADED RODS - STEEL CLASS 5.8									
Minimum embedment depth	[kN]	9.00	14.0	21.0	39.0	61.0	88.0	140.0	
Maximum embedment depth	[kN]	9.00	14.0	21.0	39.0	61.0	88.0	140.0	
R-STUDS METRIC THREADED RODS - STEEL CLASS 8.8									
Minimum embedment depth	[kN]	15.0	23.0	34.0	63.0	98.0	141.0	155.5	
Maximum embedment depth	[kN]	15.0	23.0	34.0	63.0	98.0	141.0	224.0	
R-STUDS METRIC THREADED RODS - A4									
Minimum embedment depth	[kN]	13.0	20.0	29.0	55.0	86.0	124.0	155.5	
Maximum embedment depth	[kN]	13.0	20.0	29.0	55.0	86.0	124.0	196.0	
DESIGN LOAD									
TENSION LOAD N_{Rd}									
R-STUDS METRIC THREADED RODS - STEEL CLASS 5.8									
Minimum embedment depth	[kN]	7.94	12.2	15.9	25.1	35.6	35.2	37.1	
Maximum embedment depth	[kN]	12.0	19.3	28.0	47.8	71.2	72.9	80.8	
R-STUDS METRIC THREADED RODS - STEEL CLASS 8.8									
Minimum embedment depth	[kN]	7.94	12.2	15.9	25.1	35.6	35.2	37.1	
Maximum embedment depth	[kN]	13.3	20.9	28.8	47.8	71.2	72.9	80.8	
R-STUDS METRIC THREADED RODS - A4									
Minimum embedment depth	[kN]	7.94	12.2	15.9	25.1	35.6	35.2	37.1	
Maximum embedment depth	[kN]	13.3	20.9	28.8	47.8	71.2	72.9	80.8	
SHEAR LOAD V_{Rd}									
R-STUDS METRIC THREADED RODS - STEEL CLASS 5.8									
Minimum embedment depth	[kN]	7.20	11.2	16.8	31.2	48.8	70.4	103.7	
Maximum embedment depth	[kN]	7.20	11.2	16.8	31.2	48.8	70.4	112.0	
R-STUDS METRIC THREADED RODS - STEEL CLASS 8.8									
Minimum embedment depth	[kN]	12.0	18.4	27.2	50.4	78.4	112.8	103.7	
Maximum embedment depth	[kN]	12.0	18.4	27.2	50.4	78.4	112.8	179.2	
R-STUDS METRIC THREADED RODS - A4									
Minimum embedment depth	[kN]	8.33	12.8	18.6	35.3	55.1	79.5	103.7	
Maximum embedment depth	[kN]	8.33	12.8	18.6	35.3	55.1	79.5	125.6	

Basic performance data (cont.)

R-STUDS

Performance data for single anchor without influence of edge distance and spacing

RECOMMENDED LOAD								
TENSION LOAD N_{rec}								
R-STUDS METRIC THREADED RODS - STEEL CLASS 5.8								
Minimum embedment depth	[kN]	5.68	8.73	11.4	18.0	25.4	25.1	26.5
Maximum embedment depth	[kN]	8.57	13.8	20.0	34.1	50.9	52.1	57.7
R-STUDS METRIC THREADED RODS - STEEL CLASS 8.8								
Minimum embedment depth	[kN]	5.67	8.73	11.4	17.9	25.4	25.1	26.5
Maximum embedment depth	[kN]	8.57	13.8	20.0	34.1	50.9	52.1	57.7
R-STUDS METRIC THREADED RODS - A4								
Minimum embedment depth	[kN]	5.67	8.73	11.4	17.9	25.4	25.1	26.5
Maximum embedment depth	[kN]	8.57	13.8	20.0	34.1	50.9	52.1	57.7
SHEAR LOAD V_{rec}								
R-STUDS METRIC THREADED RODS - STEEL CLASS 5.8								
Minimum embedment depth	[kN]	5.14	8.00	12.0	22.3	34.9	50.3	74.1
Maximum embedment depth	[kN]	5.14	8.00	12.0	22.3	34.9	50.3	80.0
R-STUDS METRIC THREADED RODS - STEEL CLASS 8.8								
Minimum embedment depth	[kN]	8.57	13.1	19.4	36.0	56.0	80.6	74.1
Maximum embedment depth	[kN]	8.57	13.1	19.4	36.0	56.0	80.6	128.0
R-STUDS METRIC THREADED RODS - A4								
Minimum embedment depth	[kN]	5.95	9.16	13.3	25.2	39.4	56.8	74.1
Maximum embedment depth	[kN]	5.95	9.16	13.3	25.2	39.4	56.8	89.7

Product commercial data

Product Code	Volume [ml]	Quantity [pcs]			Weight [kg]			Bar Codes
		Box	Outer	Pallet	Box	Outer	Pallet	
R-KF2-300	300	10	10	840	5.9	5.9	529.0	5906675431017
R-KF2-345	345	10	10	840	7.0	7.0	618.0	5906675343396
R-KF2-380	380	10	10	560	8.2	8.2	486.1	5010445602009
R-KF2-400	400	10	10	560	8.2	8.2	489.2	5906675392080

CFS+ CARTRIDGE FREE SYSTEM

- RV200
 - with Threaded Rods
 - with Sockets
 - with Rebar as an Anchor
 - with Post-Installed Rebar
- RM50
 - with Threaded Rods for Concrete
 - with Threaded Rods for Masonry
- RP30
 - with Threaded Rods



Patented self-opening clip

Cartridge-free system for less waste



Effortless extrusion with manual or pneumatic dispenser guns



RV200 with Threaded Rods (CFS+)

High performance vinylester resin approved for use in cracked and non-cracked concrete - Cartridge Free System (CFS+)



Approvals and Reports

- ETA-10/0055



Installation movie

Product overview

Features and benefits

- Approved for use with threaded rods for use in cracked and non-cracked concrete (ETAG001 Option 1)
- Suitable for use in low temperatures (down to -20°C for winter option) enables use throughout the year
- Suitable for use in dry and wet substrates as well as holes and substrates covered with water
- Anchor does not generate tensions in the substrate which enables RV200 to be specified where closer edge and spacing distances are required
- Unique soft foil pack for less waste
- Effortless extrusion due to the patented self-opening system with manual or battery dispenser guns
- Very high load capacity

Applications

- Curtain walling
- Balustrading
- Handrails
- Canopies
- Cable trays
- Formwork support systems
- Heavy machinery
- Lighting columns
- Public seating
- Large panel reinforcing system -Copy Eco

Base materials

Approved for use in:

- Cracked concrete C20/25-C50/60
- Non-cracked concrete C20/25-C50/60

Also suitable for use in:

- High-Density Natural Stone (after site testing)
- Natural Stone
- Solid Brick
- Solid Concrete Block
- Solid Sand-lime Brick
- Reinforced concrete

Installation guide

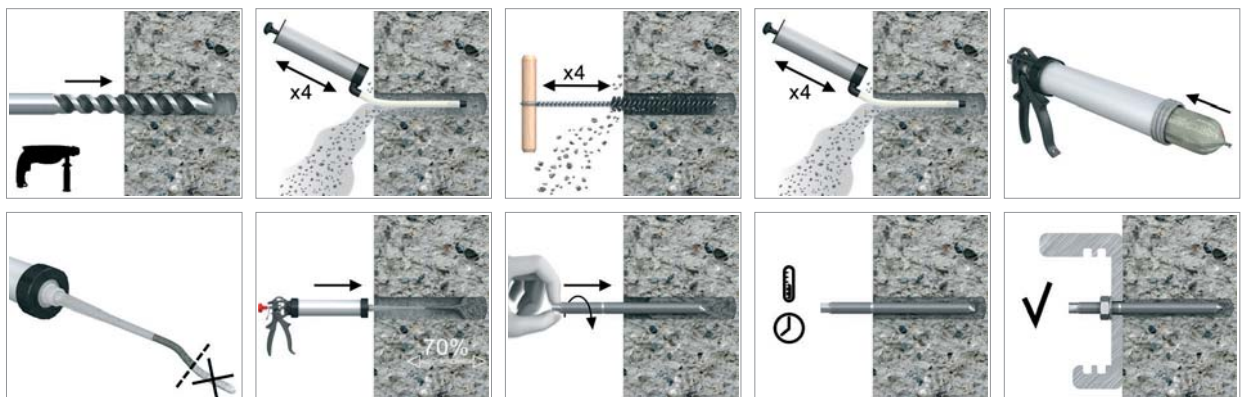

Installation guide (cont.)

1. Drill hole to the required diameter and depth for rebar size being used.
2. Clean the hole thoroughly with brush and hand pump at least four times before installation.
3. Insert foil into gun and attach nozzle.
4. Dispense to waste until even colour is obtained.
5. Insert the mixer nozzle to the bottom of the drill hole and inject resin, slowly withdrawing the nozzle as the hole is filled to 70% of its depth.
6. Immediately insert rebar, slowly and with slight twisting motion. Remove any excess resin around the hole before it sets and leave it undisturbed until the curing time elapses.
7. Attach fixture and tighten the nut to the required torque.

Product information

Product Code	Resin	Description / Resin Type	Volume
			[ml]
R-CFS+RV200-4	RV200	Styrene Free Vinylester Resin	300
R-CFS+RV200W-4	RV200-W	Low Temperature (Winter) / Rapid Cure Styrene Free Vinylester Resin	
R-CFS+RV200S-4	RV200-S	High Temperature (Summer) / Slow Cure Styrene Free Polyester Resin	
R-CFS+RV200-600-8	RV200	Styrene Free Vinylester Resin	600
R-CFS+RV200TW-6008	RV200TW	Low Temperature (Winter) / Rapid Cure Styrene Free Vinylester Resin	

R-STUDS

Size	Product Code			Anchor		Fixture		
	Steel class 5.8	Steel class 8.8	Steel grade A4	Diameter	Length	Hole diameter	Max. thickness	
				d	L	d _f	t _{fix} for h _{nom,min}	t _{fix} for h _{nom,max}
				[mm]	[mm]	[mm]	[mm]	[mm]
M8	R-STUDS-08110	R-STUDS-08110-88	R-STUDS-08110-A4	8	110	9	40	-
	R-STUDS-08160	-	R-STUDS-08160-A4*	8	160	9	90	50
M10	R-STUDS-10130	R-STUDS-10130-88	R-STUDS-10130-A4	10	130	12	48	-
	R-STUDS-10170	-	R-STUDS-10170-A4*	10	170	12	88	38
	R-STUDS-10190	-	R-STUDS-10190-A4*	10	190	12	108	58
M12	R-STUDS-12160	R-STUDS-12160-88	R-STUDS-12160-A4	12	160	14	65	-
	R-STUDS-12190	-	R-STUDS-12190-A4*	12	190	14	95	30
	R-STUDS-12220	-	R-STUDS-12220-A4*	12	220	14	125	60
	R-STUDS-12260	-	R-STUDS-12260-A4*	12	260	14	165	100
	R-STUDS-12300	-	R-STUDS-12300-A4*	12	300	14	205	140
M16	R-STUDS-16190	R-STUDS-16190-88	R-STUDS-16190-A4	16	190	18	71	-
	R-STUDS-16220	R-STUDS-16220-88	R-STUDS-16220-A4*	16	220	18	101	11
	R-STUDS-16260	-	R-STUDS-16260-A4*	16	260	18	141	51
	R-STUDS-16300	-	R-STUDS-16300-A4*	16	300	18	181	91
	R-STUDS-16380	-	R-STUDS-16380-A4*	16	380	18	261	171
M20	R-STUDS-20260	R-STUDS-20260-88	R-STUDS-20260-A4	20	260	22	117	-
	R-STUDS-20300	R-STUDS-20300-88	R-STUDS-20300-A4*	20	300	22	157	37
	R-STUDS-20350	-	R-STUDS-20350-A4*	20	350	22	207	87
M24	R-STUDS-24300	R-STUDS-24300-88	R-STUDS-24300-A4*	24	300	26	132	-
M30	R-STUDS-30380	R-STUDS-30380-88	R-STUDS-30380-A4	30	380	32	181	-

* Make to order

Installation data

R-STUDS

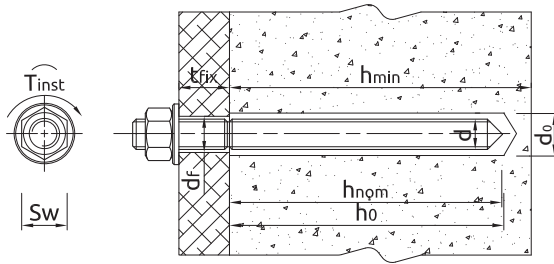

Size	M8	M10	M12	M16	M20	M24	M30		
Thread diameter	d	[mm]	8	10	12	16	20	24	30
Hole diameter in substrate	d ₀	[mm]	10	12	14	18	24	28	35
Installation torque	T _{inst}	[Nm]	10	20	40	80	120	180	300
Min. hole depth in substrate	h ₀	[mm]	h _{nom} + 5						
MINIMUM EMBEDMENT DEPTH									
Installation depth	h _{nom, min}	[mm]	60	70	80	100	120	140	165
MAXIMUM EMBEDMENT DEPTH									
Installation depth	h _{nom, max}	[mm]	100	120	145	190	240	290	360
Min. substrate thickness	h _{min}	[mm]	h _{nom} + 30 ≥ 100			h _{nom} + 2*d ₀			
Min. spacing	s _{min}	[mm]	0.5 * h _{nom} ≥ 40						
Min. edge distance	c _{min}	[mm]	0.5 * h _{nom} ≥ 40						

Minimum working and curing time

Resin temperature °C	Concrete temperature °C	Working time [min.]			Curing time* [min.]		
		RV200-S	RV200	RV200-W	RV200-S	RV200	RV200-W
5	-20	-	-	100	-	-	24 h
5	-15	-	-	60	-	-	16 h
5	-10	-	-	30	-	-	8 h
5	-5	65	60	16	24 h	6 h	4 h
5	0	50	40	12	16 h	3 h	2 h
5	5	35	20	8	12 h	2 h	1 h
10	10	20	12	5	8 h	80	45
15	15	12	8	3	6 h	60	30
20	20	9	5	2	4 h	45	10
25	25	7	3	-	3 h	30	-
25	30	6	2	-	2 h	20	-
25	40	4	0.5	-	45	10	-
25	45	3	-	-	35	-	-
25	50	2	-	-	25	-	-

*For wet concrete the curing time must be doubled

Mechanical properties

R-STUDS

Size	M8	M10	M12	M16	M20	M24	M30		
R-STUDS METRIC THREADED RODS - steel class 5.8									
Nominal ultimate tensile strength - tension	f _{uk}	[N/mm ²]	500	500	500	500	500	500	
Nominal yield strength - tension	f _{yk}	[N/mm ²]	400	400	400	400	400	400	
Cross sectional area - tension	A _s	[mm ²]	36.6	58	84.3	157	245	352.8	559.8
Elastic section modulus	W _{el}	[mm ³]	31.2	62.3	109.2	277.5	541	935	1868
Characteristic bending resistance	M ⁰ _{Rk,s}	[Nm]	19	37	65	166	324	561	1124
Design bending resistance	M	[Nm]	15	30	52	133	259	449	899
Allowable bending resistance	M _{rec}	[Nm]	11	21	37	95	185	321	642

Mechanical properties (cont.)

R-STUDS

Size			M8	M10	M12	M16	M20	M24	M30
R-STUDS METRIC THREADED RODS - steel class 8.8									
Nominal ultimate tensile strength - tension	f_{uk}	[N/mm ²]	800	800	800	800	800	800	800
Nominal yield strength - tension	f_{yk}	[N/mm ²]	640	640	640	640	640	640	640
Cross sectional area - tension	A_s	[mm ²]	36.6	58	84.3	157	245	352.8	559.8
Elastic section modulus	W_{el}	[mm ³]	31.2	62.3	109.2	277.5	541	935	1868
Characteristic bending resistance	$M_{Rk,s}^0$	[Nm]	30	60	105	266	519	898	1799
Design bending resistance	M	[Nm]	24	48	84	213	416	718	1439
Allowable bending resistance	M_{rec}	[Nm]	17	34	60	152	297	513	1028
R-STUDS METRIC THREADED RODS - A4									
Nominal ultimate tensile strength - tension	f_{uk}	[N/mm ²]	700	700	700	700	700	700	700
Nominal yield strength - tension	f_{yk}	[N/mm ²]	350	350	350	350	350	350	350
Cross sectional area - tension	A_s	[mm ²]	36.6	58	84.3	157	245	352.8	559.8
Elastic section modulus	W_{el}	[mm ³]	31.2	62.3	109.2	277.5	541	935	1868
Characteristic bending resistance	$M_{Rk,s}^0$	[Nm]	26	52	92	233	454	786	1574
Design bending resistance	M	[Nm]	17	34	59	149	291	504	1009
Allowable bending resistance	M_{rec}	[Nm]	12	24	42	107	208	360	721

Basic performance data

R-STUDS

Performance data for single anchor without influence of edge distance and spacing

Size		M8	M10	M12	M16	M20	M24	M30	M12	M16	M20	M24	
Substrate		Non-cracked concrete						Cracked concrete					
CHARACTERISTIC LOAD													
TENSION LOAD N_{Rk}													
R-STUDS METRIC THREADED RODS - STEEL CLASS 5.8													
Minimum embedment depth	[kN]	18.0	28.6	36.1	50.5	66.4	83.7	107.0	19.6	22.6	30.2	42.2	
Maximum embedment depth	[kN]	18.0	41.0	42.0	78.0	122.0	176.0	237.5	35.5	43.0	60.3	87.5	
R-STUDS METRIC THREADED RODS - STEEL CLASS 8.8													
Minimum embedment depth	[kN]	19.6	28.6	36.1	50.5	66.4	83.7	107.0	19.6	22.6	30.2	42.2	
Maximum embedment depth	[kN]	29.0	46.0	67.0	105.1	143.3	196.8	237.5	35.5	43.0	60.3	87.5	
R-STUDS METRIC THREADED RODS - A4													
Minimum embedment depth	[kN]	19.6	28.6	36.1	50.5	66.4	83.7	107.0	19.6	22.6	30.2	42.2	
Maximum embedment depth	[kN]	26.0	41.0	59.0	105.1	143.3	196.8	237.5	35.5	43.0	60.3	87.5	
SHEAR LOAD V_{Rk}													
R-STUDS METRIC THREADED RODS - STEEL CLASS 5.8													
Minimum embedment depth	[kN]	9.00	20.0	21.0	39.0	61.0	88.0	140.0	21.0	39.0	60.3	84.5	
Maximum embedment depth	[kN]	9.00	20.0	21.0	39.0	61.0	88.0	140.0	21.0	39.0	61.0	88.0	
R-STUDS METRIC THREADED RODS - STEEL CLASS 8.8													
Minimum embedment depth	[kN]	15.0	23.0	34.0	63.0	98.0	141.0	214.1	34.0	45.2	60.3	84.5	
Maximum embedment depth	[kN]	15.0	23.0	34.0	63.0	98.0	141.0	224.0	34.0	63.0	98.0	141.0	
R-STUDS METRIC THREADED RODS - A4													
Minimum embedment depth	[kN]	13.0	20.0	29.0	55.0	86.0	124.0	196.0	29.0	45.2	60.3	84.5	
Maximum embedment depth	[kN]	13.0	20.0	29.0	55.0	86.0	124.0	196.0	29.0	55.0	86.0	124.0	
DESIGN LOAD													
TENSION LOAD N_{Rd}													
R-STUDS METRIC THREADED RODS - STEEL CLASS 5.8													
Minimum embedment depth	[kN]	10.9	15.9	20.1	28.1	36.9	39.8	51.0	10.9	12.6	16.8	20.1	
Maximum embedment depth	[kN]	12.0	21.9	28.0	52.0	79.6	93.7	113.1	19.7	23.9	33.5	41.7	
R-STUDS METRIC THREADED RODS - STEEL CLASS 8.8													
Minimum embedment depth	[kN]	10.9	15.9	20.1	28.1	36.9	39.8	51.0	10.9	12.6	16.8	20.1	
Maximum embedment depth	[kN]	18.2	27.2	39.5	58.4	79.6	93.7	113.1	19.7	23.9	33.5	41.7	
R-STUDS METRIC THREADED RODS - A4													
Minimum embedment depth	[kN]	10.9	15.9	20.1	28.1	36.9	39.8	51.0	10.9	12.6	16.8	20.1	
Maximum embedment depth	[kN]	18.2	21.9	31.6	58.4	79.6	93.7	113.1	19.7	23.9	33.5	41.7	

Basic performance data (cont.)

R-STUDS

Performance data for single anchor without influence of edge distance and spacing

Size		M8	M10	M12	M16	M20	M24	M30	M12	M16	M20	M24
SHEAR LOAD V_{Rd}												
R-STUDS METRIC THREADED RODS - STEEL CLASS 5.8												
Minimum embedment depth	[kN]	7.20	12.8	16.8	31.2	48.8	70.4	112.0	16.8	30.2	40.2	56.3
Maximum embedment depth	[kN]	7.20	12.8	16.8	31.2	48.8	70.4	112.0	16.8	31.2	48.8	70.4
R-STUDS METRIC THREADED RODS - STEEL CLASS 8.8												
Minimum embedment depth	[kN]	12.0	18.4	27.2	50.4	78.4	111.5	142.7	26.1	30.2	40.2	56.3
Maximum embedment depth	[kN]	12.0	18.4	27.2	50.4	78.4	112.8	179.2	27.2	50.4	78.4	112.8
R-STUDS METRIC THREADED RODS - A4												
Minimum embedment depth	[kN]	8.33	12.8	18.6	35.3	55.1	79.5	125.6	18.6	30.2	40.2	56.3
Maximum embedment depth	[kN]	8.33	12.8	18.6	35.3	55.1	79.5	125.6	18.6	35.3	55.1	79.5
RECOMMENDED LOAD												
TENSION LOAD N_{rec}												
R-STUDS METRIC THREADED RODS - STEEL CLASS 5.8												
Minimum embedment depth	[kN]	7.78	11.3	14.3	20.0	26.3	28.5	36.4	7.78	8.98	12.0	14.4
Maximum embedment depth	[kN]	8.57	15.7	20.0	37.1	56.9	66.9	80.8	14.1	17.1	23.9	29.8
R-STUDS METRIC THREADED RODS - STEEL CLASS 8.8												
Minimum embedment depth	[kN]	7.78	11.3	14.3	20.0	26.3	28.5	36.4	7.78	8.98	12.0	14.4
Maximum embedment depth	[kN]	8.57	19.5	28.2	41.7	56.9	66.9	80.8	14.1	17.1	23.9	29.8
R-STUDS METRIC THREADED RODS - A4												
Minimum embedment depth	[kN]	7.78	11.3	14.3	20.0	26.3	28.5	36.4	7.78	8.98	12.0	14.4
Maximum embedment depth	[kN]	9.93	15.7	22.5	41.7	56.9	66.9	80.8	14.1	17.1	23.9	29.8
SHEAR LOAD V_{rec}												
R-STUDS METRIC THREADED RODS - STEEL CLASS 5.8												
Minimum embedment depth	[kN]	5.14	9.16	12.0	22.3	34.9	50.3	80.0	12.0	21.5	28.7	40.2
Maximum embedment depth	[kN]	5.14	9.16	12.0	22.3	34.9	50.3	80.0	12.0	22.3	34.9	50.3
R-STUDS METRIC THREADED RODS - STEEL CLASS 8.8												
Minimum embedment depth	[kN]	8.57	13.1	19.4	36.0	56.0	79.7	101.9	18.7	21.5	28.7	40.2
Maximum embedment depth	[kN]	8.57	13.1	19.4	36.0	56.0	80.6	128.0	19.4	36.0	56.0	80.6
R-STUDS METRIC THREADED RODS - A4												
Minimum embedment depth	[kN]	5.95	9.16	13.3	25.2	39.4	56.8	89.7	13.3	21.5	28.7	40.2
Maximum embedment depth	[kN]	5.95	9.16	13.3	25.2	39.4	56.8	89.7	13.28	25.2	39.4	56.8

Product commercial data

Product Code	Volume [ml]	Quantity [pcs]			Weight [kg]			Bar Codes
		Box	Outer	Pallet	Box	Outer	Pallet	
R-CFS+RV200-4	300	1	8	96	2.4	19.3	261.3	5906675205830
R-CFS+RV200W-4	300	1	8	96	2.4	19.5	264.2	5906675375762
R-CFS+RV200S-4	300	1	8	96	2.4	-	-	5906675201375
R-CFS+RV200-600-8	600	1	1	36	10.0	10.0	390.0	5906675119045
R-CFS+RV200TW-6008	600	1	1	36	10.0	10.0	390.0	5906675328270

RV200 with Sockets (CFS+)

High performance vinylester resin approved for use with internally threaded sockets - Cartridge Free System (CFS+)



Approvals and Reports

- ETA-13/0805



Product overview

Features and benefits

- Allows removal of bolt to leave a re-usable socket in place
- Approved for use in non-cracked concrete
- Suitable for use in low temperatures (down to -20°C for winter option) enables use throughout the year
- Suitable for use in dry and wet substrates as well as holes and substrates covered with water
- Anchor does not generate tensions in the substrate which enables RV200 to be specified where closer edge and spacing distances are required
- Unique soft foil pack for less waste
- Effortless extrusion due to patented self-opening system with manual or battery dispenser guns

Applications

- Curtain walling
- Balustrading
- Handrails
- Canopies
- Cable trays
- Formwork support systems
- Heavy machinery
- Lighting columns
- Public seating

Base materials

Approved for use in:

- Non-cracked concrete C20/25-C50/60

Also suitable for use in:

- Natural Stone
- Solid Concrete Block
- Solid Brick

Installation guide

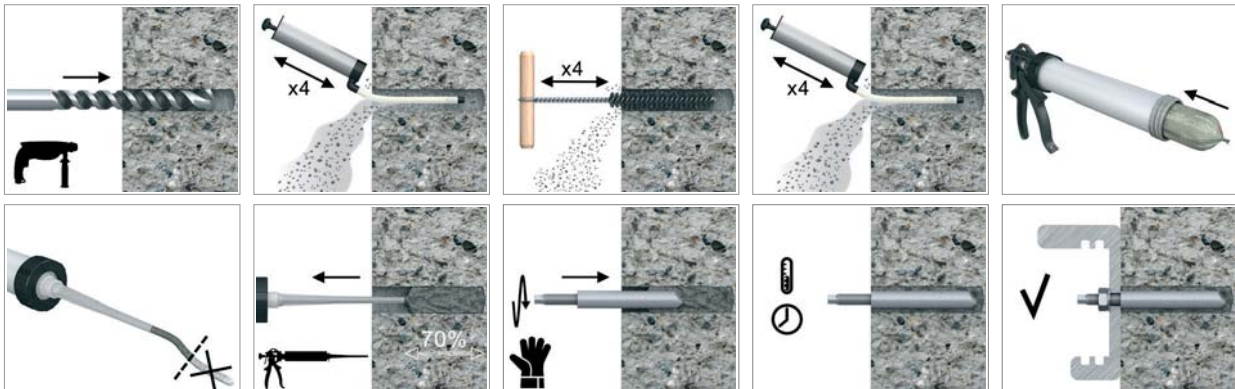

Installation guide (cont.)

1. Drill hole to the required diameter and depth for socket size being used.
2. Clean the hole thoroughly with brush and hand pump at least four times before installation.
3. Insert foil into gun and attach nozzle.
4. Dispense to waste until even colour is obtained.
5. Insert the mixer nozzle to the bottom of the drill hole and inject resin, slowly withdrawing the nozzle as the hole is filled to 70% of its depth.
6. Immediately insert the stud, slowly and with slight twisting motion. Remove any excess resin around the hole before it sets and leave it undisturbed until the curing time elapses.

Product information

Product Code	Resin	Description / Resin Type	Volume
			[ml]
R-CFS+RV200-4	RV200	Styrene Free Vinylester Resin	300
R-CFS+RV200W-4	RV200-W	Low Temperature (Winter) / Rapid Cure Styrene Free Vinylester Resin	
R-CFS+RV200S-4	RV200-S	High Temperature (Summer) / Slow Cure Styrene Free Polyester Resin	
R-CFS+RV200-600-8	RV200	Styrene Free Vinylester Resin	600
R-CFS+RV200TW-6008	RV200TW	Low Temperature (Winter) / Rapid Cure Styrene Free Vinylester Resin	

SOCKETS

Size	Product Code		Anchor			Fixture
	Steel class 5.8	Steel grade A4	Socket diameter	Length	Internal thread length	Hole diameter
			d	L	l_b	d_f
			[mm]	[mm]	[mm]	[mm]
M6	R-ITS-Z-06075	R-ITS-A4-06075	10	75	24	7
M8	R-ITS-Z-08075	R-ITS-A4-08075	12	75	25	9
	R-ITS-Z-08090	R-ITS-A4-08090	12	90	25	9
M10	R-ITS-Z-10075	R-ITS-A4-10075	16	75	30	12
	R-ITS-Z-10100	R-ITS-A4-10100	16	100	30	12
M12	R-ITS-Z-12100	R-ITS-A4-12100	16	100	35	14
M16	R-ITS-Z-16125	R-ITS-A4-16125	24	125	50	18

Installation data

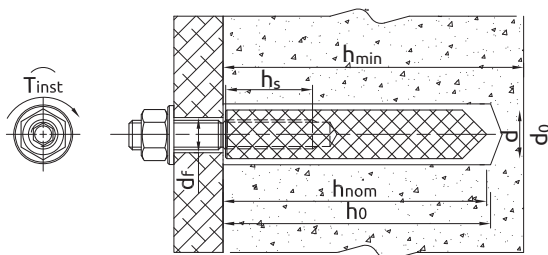

SOCKETS

Size			M6	M8		M10		M12	M16
Thread diameter	d	[mm]	6	8	8	10	10	12	16
Hole diameter in substrate	d_0	[mm]	12	14	14	20	20	20	28
Hole diameter in fixture	d_f	[mm]	7	9	9	12	12	14	18
Installation torque	T_{inst}	[Nm]	3	5	5	10	10	20	40
Thread engagement length; min-max	h_s	[mm]	6-24	8-25	8-25	10-30	10-30	12-35	16-50
Min. hole depth in substrate	h_0	[mm]	$h_{nom} + 5$						

Installation data (cont.)

SOCKETS

Size			M6	M8		M10		M12	M16
Effective Installation depth	h_{nom}	[mm]	75	75	90	75	100	100	125
Min. substrate thickness	h_{min}	[mm]	105	105	120	115	140	140	181
Min. spacing	s_{min}	[mm]	40	40	45	40	50	50	63
Min. edge distance	c_{min}	[mm]	40	40	45	40	50	50	63

Minimum working and curing time

Resin temperature [°C]	Concrete temperature [°C]	Working time [min]			Curing time* [min]		
		RV200-S	RV200	RV200-W	RV200-S	RV200	RV200-W
5	-20	-	-	100	-	-	24h
5	-15	-	-	60	-	-	16h
5	-10	-	-	30	-	-	8h
5	-5	65	60	16	24h	6h	4h
5	0	50	40	12	16h	3h	2h
5	5	35	20	8	12h	2h	1h
10	10	20	12	5	8h	80	45
15	15	12	8	3	6h	60	30
20	20	9	5	2	4h	45	10
25	25	7	3	-	3h	30	-
25	30	6	2	-	2h	20	-
25	40	5	0.5	-	45	10	-
25	45	3	-	-	35	-	-
25	50	2	-	-	25	-	-

*For wet concrete the curing time must be doubled

Mechanical properties

SOCKETS

Size			M6	M8	M10	M12	M16
R-ITS-A4 INTERNALLY THREADED SOCKETS							
Nominal ultimate tensile strength - tension	f_{uk}	[N/mm ²]	700	700	700	700	700
Nominal yield strength - tension	f_{yk}	[N/mm ²]	350	350	350	350	350
Cross sectional area - tension	A_s	[mm ²]	20.1	36.6	58	84.3	157
Elastic section modulus	W_{el}	[mm ³]	21.21	50.27	98.17	169.65	402.12
R-ITS-Z INTERNALLY THREADED SOCKETS							
Nominal ultimate tensile strength - tension	f_{uk}	[N/mm ²]	520	500	500	500	500
Nominal yield strength - tension	f_{yk}	[N/mm ²]	420	400	400	400	400
Cross sectional area - tension	A_s	[mm ²]	20.1	36.6	58	84.3	157
Elastic section modulus	W_{el}	[mm ³]	21.21	50.27	98.17	169.65	402.12
R-STUDS METRIC THREADED RODS - steel class 5.8							
Characteristic bending resistance	$M_{Rk,s}^0$	[Nm]	8	19	37	65	166
Design bending resistance	M	[Nm]	6	15	30	52	133
Allowable bending resistance	M_{rec}	[Nm]	5	11	21	37	95
R-STUDS METRIC THREADED RODS - steel class 8.8							
Characteristic bending resistance	$M_{Rk,s}^0$	[Nm]	12	30	60	105	266
Design bending resistance	M	[Nm]	10	24	48	84	213
Allowable bending resistance	M_{rec}	[Nm]	7	17	34	60	152
R-STUDS METRIC THREADED RODS - A4							
Characteristic bending resistance	$M_{Rk,s}^0$	[Nm]	11	26	52	92	233
Design bending resistance	M	[Nm]	7	17	34	59	149
Allowable bending resistance	M_{rec}	[Nm]	5	12	24	42	107

Basic performance data

SOCKETS

Performance data for single anchor without influence of edge distance and spacing

Size		M6	M8	M10	M12	M16		
Substrate		Non-cracked concrete						
Embedment depth h_{nom}	[mm]	75	75	90	75	100	100	125
CHARACTERISTIC LOAD								
TENSION LOAD N_{Rk}								
R-STUDS METRIC THREADED RODS - STEEL CLASS 5.8	[kN]	10.00	18.0	18.0	29.0	29.0	42.0	66.0
R-STUDS METRIC THREADED RODS - STEEL CLASS 8.8	[kN]	16.0	25.4	29.0	32.8	46.0	42.7	66.0
R-STUDS METRIC THREADED RODS - A4	[kN]	14.0	25.4	26.0	32.8	41.0	42.7	66.0
SHEAR LOAD V_{Rk}								
R-STUDS METRIC THREADED RODS - STEEL CLASS 5.8	[kN]	5.00	9.00	9.00	14.0	14.0	21.0	39.0
R-STUDS METRIC THREADED RODS - STEEL CLASS 8.8	[kN]	8.00	15.0	15.0	23.0	23.0	34.0	63.0
R-STUDS METRIC THREADED RODS - A4	[kN]	7.00	13.0	13.0	20.0	20.0	29.0	55.0
DESIGN LOAD								
TENSION LOAD N_{Rd}								
R-STUDS METRIC THREADED RODS - STEEL CLASS 5.8	[kN]	6.70	12.0	12.0	18.2	19.3	23.7	36.7
R-STUDS METRIC THREADED RODS - STEEL CLASS 8.8	[kN]	9.82	14.1	17.0	18.2	26.5	23.7	36.7
R-STUDS METRIC THREADED RODS - A4	[kN]	7.49	13.9	13.9	18.2	21.9	23.7	36.7
SHEAR LOAD V_{Rd}								
R-STUDS METRIC THREADED RODS - STEEL CLASS 5.8	[kN]	4.00	7.20	7.20	11.2	11.2	16.8	31.2
R-STUDS METRIC THREADED RODS - STEEL CLASS 8.8	[kN]	6.40	12.0	12.0	18.4	18.4	27.2	50.4
R-STUDS METRIC THREADED RODS - A4	[kN]	4.49	8.33	8.33	12.8	12.8	18.6	35.3
RECOMMENDED LOAD								
TENSION LOAD N_{rec}								
R-STUDS METRIC THREADED RODS - STEEL CLASS 5.8	[kN]	4.79	8.57	8.57	13.0	13.8	16.9	26.2
R-STUDS METRIC THREADED RODS - STEEL CLASS 8.8	[kN]	7.01	10.1	12.1	13.0	18.9	16.9	26.2
R-STUDS METRIC THREADED RODS - A4	[kN]	5.35	9.93	9.93	13.0	15.6	16.9	26.2
SHEAR LOAD V_{rec}								
R-STUDS METRIC THREADED RODS - STEEL CLASS 5.8	[kN]	2.86	5.14	5.14	8.00	8.00	12.0	22.3
R-STUDS METRIC THREADED RODS - STEEL CLASS 8.8	[kN]	4.57	8.57	8.57	13.1	13.1	19.4	36.0
R-STUDS METRIC THREADED RODS - A4	[kN]	3.21	5.95	5.95	9.16	9.16	13.3	25.2

Product commercial data

Product Code	Volume [ml]	Quantity [pcs]			Weight [kg]			Bar Codes
		Box	Outer	Pallet	Box	Outer	Pallet	
R-CFS+RV200-4 ¹⁾	300	1	8	96	2.4	19.3	261.3	5906675205830
R-CFS+RV200W-4 ¹⁾	300	1	8	96	2.4	19.5	264.2	5906675375762
R-CFS+RV200S-4 ¹⁾	300	1	8	96	-	-	-	5906675201375
R-CFS+RV200-600-8 ¹⁾	600	1	1	36	10.0	10.0	390.0	5906675119045
R-CFS+RV200TW-6008 ¹⁾	600	1	1	36	10.0	10.0	390.0	5906675328270

RV200 with Rebar as an Anchor (CFS+)

High performance vinylester resin approved for use with reinforcement bars - Cartridge Free System (CFS+)



Approvals and Reports

- ETA-13/0805



Installation movie

Product overview

Features and benefits

- Approved for use with rebar as an anchor for use in non-cracked concrete
- Suitable for use in low temperatures (down to -20°C for winter option) enables use throughout the year
- Suitable for use in dry and wet substrates as well as holes and substrates covered with water
- Anchor does not generate tensions in the substrate which enables RV200 to be specified where closer edge and spacing distances are required
- Winter version can be used in warmer temperatures for faster curing
- Unique soft foil pack for less waste

Applications

- Replacement of incorrectly placed / missing reinforcing bars
- Renovation of: buildings, bridges and other civil structures,
- Re-strengthening of concrete
- Anchoring structural steel connections (e.g. steel columns, beams, etc.)
- Rebar doweling / connection of secondary post-installed rebars
- Anchoring secondary steel elements
- Connectors for additional concrete layer

Base materials

Approved for use in:

- Non-cracked concrete C20/25-C50/60

Installation guide

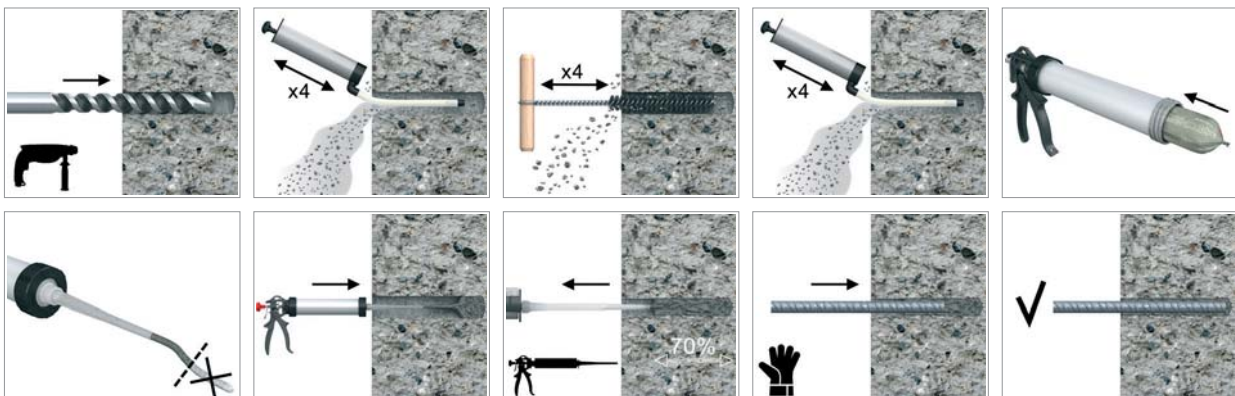

Installation guide (cont.)

1. Drill hole to the required diameter and depth for rebar size being used.
2. Clean the hole thoroughly with brush and hand pump at least four times before installation.
3. Insert foil into gun and attach nozzle.
4. Dispense to waste until even colour is obtained.
5. Insert the mixer nozzle to the bottom of the drill hole and inject resin, slowly withdrawing the nozzle as the hole is filled to 70% of its depth.
6. Immediately insert rebar, slowly and with slight twisting motion. Remove any excess resin around the hole before it sets and leave it undisturbed until the curing time elapses.

Product information

Product Code	Resin	Description / Resin Type	Volume
			[ml]
R-CFS+RV200-4	RV200	Styrene Free Vinylester Resin	300
R-CFS+RV200W-4	RV200-W	Low Temperature (Winter) / Rapid Cure Styrene Free Vinylester Resin	
R-CFS+RV200S-4	RV200-S	High Temperature (Summer) / Slow Cure Styrene Free Polyester Resin	
R-CFS+RV200-600-8	RV200	Styrene Free Vinylester Resin	600
R-CFS+RV200TW-6008	RV200TW	Low Temperature (Winter) / Rapid Cure Styrene Free Vinylester Resin	

Installation data

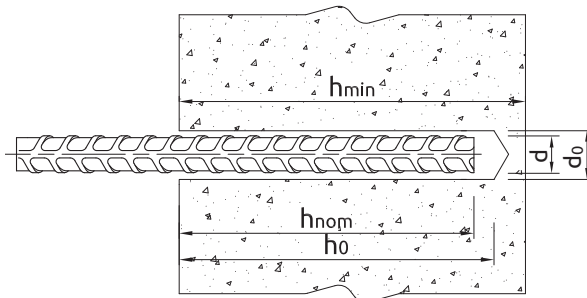

REBARS AS ANCHORS

Size			Ø8	Ø10	Ø12	Ø14	Ø16	Ø20	Ø25	Ø32
Thread diameter	d	[mm]	8	10	12	14	16	20	25	32
Hole diameter in substrate	d ₀	[mm]	12	14	18		22	26	32	40
Min. hole depth in substrate	h ₀	[mm]	h _{nom} + 5							
MINIMUM EMBEDMENT DEPTH										
Installation depth	h _{nom, min}	[mm]	60	70	80		100	120	140	165
MAXIMUM EMBEDMENT DEPTH										
Installation depth	h _{nom, max}	[mm]	100	120	145		190	240	290	360
Min. substrate thickness	h _{min}	[mm]	h _{ef} + 30 ≥ 100			h _{ef} + 2*d ₀				
Min. spacing	s _{min}	[mm]	0.5 * h _{nom} ≥ 40							
Min. edge distance	c _{min}	[mm]	0.5 * h _{nom} ≥ 40							

Installation data (cont.)

Minimum working and curing time

Resin temperature °C	Concrete temperature °C	Working time [min]			Curing time* [min.]		
		RV200-S	RV200	RV200-W	RV200-S	RV200	RV200-W
5	-20	-	-	100	-	-	24 h
5	-15	-	-	60	-	-	16 h
5	-10	-	-	30	-	-	8 h
5	-5	65	60	16	24 h	6 h	4 h
5	0	50	40	12	16 h	3 h	2 h
5	5	35	20	8	12 h	2 h	1 h
10	10	20	12	5	8 h	80	45
15	15	12	8	3	6 h	60	30
20	20	9	5	2	4 h	45	10
25	25	7	3	-	3 h	30	-
25	30	6	2	-	2 h	20	-
25	40	5	0.5	-	45	10	-
25	45	3	-	-	35	-	-
25	50	2	-	-	25	-	-

*For wet concrete the curing time must be doubled

Mechanical properties

REBARS AS ANCHORS

Size	Ø8	Ø10	Ø12	Ø14	Ø16	Ø20	Ø25	Ø32
f_{uk} = 540 (e.g. 500 B acc. to BS 4449; B 500 B acc. to SS 560)								
Nominal ultimate tensile strength - tension	f _{uk}	[N/mm ²]	540	540	540	540	540	540
Nominal yield strength - tension	f _{yk}	[N/mm ²]	500	500	500	500	500	500
Cross sectional area - tension	A _s	[mm ²]	50.3	78.5	113.1	153.9	201.1	314.2
Elastic section modulus	W _{el}	[mm ³]	50.3	98.2	169.6	269.4	402.1	785.4
f_{uk} = 540 (e.g. 500 B acc. to BS 4449; B 500 B acc. to SS 560)								
Nominal ultimate tensile strength - tension	f _{uk}	[N/mm ²]	575	575	575	575	575	575
Nominal yield strength - tension	f _{yk}	[N/mm ²]	500	500	500	500	500	500
Cross sectional area - tension	A _s	[mm ²]	50.3	78.5	113.1	153.9	201.1	314.2
Elastic section modulus	W _{el}	[mm ³]	50.3	98.2	169.6	269.4	402.1	785.4
f_{uk} = 620 (e.g. G-60 acc. to ASTM 615)								
Nominal ultimate tensile strength - tension	f _{uk}	[N/mm ²]	620	620	620	620	620	620
Nominal yield strength - tension	f _{yk}	[N/mm ²]	420	420	420	420	420	420
Cross sectional area - tension	A _s	[mm ²]	50.3	78.5	113.1	153.9	201.1	314.2
Elastic section modulus	W _{el}	[mm ³]	50.3	98.2	169.6	269.4	402.1	785.4

Basic performance data

REBARS AS ANCHORS

Size		Ø8	Ø10	Ø12	Ø14	Ø16	Ø20	Ø25	Ø32
Substrate		Non-cracked concrete							
CHARACTERISTIC LOAD									
TENSION LOAD N_{Rk}									
$f_{uk} = 540$ (e.g. 500 B acc. to BS 4449; B 500 B acc. to SS 560)									
Minimum embedment depth	[kN]	16.6	22.0	30.2	31.7	45.3	56.6	77.0	107.0
Maximum embedment depth	[kN]	27.1	37.7	54.7	57.4	86.0	113.1	159.4	235.2
$f_{uk} = 575$ (e.g. B 500 SP acc. to EC2)									
Minimum embedment depth	[kN]	16.6	22.0	30.2	31.7	45.2	56.6	77.0	107.0
Maximum embedment depth	[kN]	27.7	37.7	54.7	57.4	86.0	113.1	159.4	235.2
$f_{uk} = 620$ (e.g. G-60 acc. to ASTM 615)									
Minimum embedment depth	[kN]	16.6	22.0	30.2	31.7	45.2	56.6	77.0	107.0
Maximum embedment depth	[kN]	27.7	37.7	54.7	57.4	86.0	113.1	159.4	235.2
SHEAR LOAD V_{Rk}									
$f_{uk} = 540$ (e.g. 500 B acc. to BS 4449; B 500 B acc. to SS 560)									
Minimum embedment depth	[kN]	13.6	21.2	30.5	41.6	54.3	84.8	132.5	214.1
Maximum embedment depth	[kN]	13.6	21.2	30.5	41.6	54.3	84.8	132.5	217.2
$f_{uk} = 575$ (e.g. B 500 SP acc. to EC2)									
Minimum embedment depth	[kN]	14.5	22.6	32.5	44.3	57.8	90.3	141.1	214.1
Maximum embedment depth	[kN]	14.5	22.6	32.5	44.3	57.8	90.3	141.1	231.2
$f_{uk} = 620$ (e.g. G-60 acc. to ASTM 615)									
Minimum embedment depth	[kN]	15.6	24.4	35.1	47.7	62.3	97.4	152.2	214.1
Maximum embedment depth	[kN]	15.6	24.4	35.1	47.7	62.3	97.4	152.2	249.3
DESIGN LOAD									
TENSION LOAD N_{Rd}									
$f_{uk} = 540$ (e.g. 500 B acc. to BS 4449; B 500 B acc. to SS 560)									
Minimum embedment depth	[kN]	9.22	12.2	16.8	17.6	25.1	31.4	42.8	59.5
Maximum embedment depth	[kN]	15.4	20.9	30.4	31.9	47.8	62.8	88.6	130.7
$f_{uk} = 575$ (e.g. B 500 SP acc. to EC2)									
Minimum embedment depth	[kN]	9.22	12.2	16.8	17.6	25.1	31.4	42.8	59.5
Maximum embedment depth	[kN]	15.4	20.9	30.4	31.9	47.8	62.8	88.6	130.7
$f_{uk} = 620$ (e.g. G-60 acc. to ASTM 615)									
Minimum embedment depth	[kN]	9.22	12.2	16.8	17.6	25.1	31.4	42.8	59.5
Maximum embedment depth	[kN]	15.4	20.9	30.4	31.9	47.8	62.8	88.6	130.7
SHEAR LOAD V_{Rd}									
$f_{uk} = 540$ (e.g. 500 B acc. to BS 4449; B 500 B acc. to SS 560)									
Minimum embedment depth	[kN]	9.05	14.1	20.4	27.7	36.2	56.6	88.4	142.7
Maximum embedment depth	[kN]	9.05	14.1	20.4	27.7	36.2	56.6	88.4	144.8
$f_{uk} = 575$ (e.g. B 500 SP acc. to EC2)									
Minimum embedment depth	[kN]	9.63	15.1	21.7	29.5	38.5	60.2	94.1	142.7
Maximum embedment depth	[kN]	9.63	15.1	21.7	29.5	38.5	60.2	94.1	154.2
$f_{uk} = 620$ (e.g. G-60 acc. to ASTM 615)									
Minimum embedment depth	[kN]	10.4	16.2	23.4	31.8	41.6	64.9	101.5	142.7
Maximum embedment depth	[kN]	10.4	16.2	23.4	31.8	41.6	64.9	101.5	166.2

Basic performance data (cont.)

REBARS AS ANCHORS

Size		Ø8	Ø10	Ø12	Ø14	Ø16	Ø20	Ø25	Ø32
RECOMMENDED LOAD									
TENSION LOAD N_{rec}									
$f_{uk} = 540$ (e.g. 500 B acc. to BS 4449; B 500 B acc. to SS 560)									
Minimum embedment depth	[kN]	6.58	8.73	12.0	12.6	18.0	22.4	30.5	42.3
Maximum embedment depth	[kN]	11.0	15.0	21.7	22.8	34.1	44.9	63.3	93.4
$f_{uk} = 575$ (e.g. B 500 SP acc. to EC2)									
Minimum embedment depth	[kN]	6.58	8.73	12.0	12.6	18.0	22.4	30.5	42.5
Maximum embedment depth	[kN]	11.0	15.0	21.7	22.8	34.1	44.9	63.3	93.4
$f_{uk} = 620$ (e.g. G-60 acc. to ASTM 615)									
Minimum embedment depth	[kN]	6.58	8.73	12.0	12.6	18.0	22.4	30.5	42.5
Maximum embedment depth	[kN]	11.0	15.0	21.7	22.8	34.1	44.9	63.3	93.6
SHEAR LOAD V_{rec}									
$f_{uk} = 540$ (e.g. 500 B acc. to BS 4449; B 500 B acc. to SS 560)									
Minimum embedment depth	[kN]	6.46	10.1	14.5	19.8	25.9	40.4	63.1	101.9
Maximum embedment depth	[kN]	6.46	10.1	14.5	19.8	25.9	40.4	63.1	103.4
$f_{uk} = 575$ (e.g. B 500 SP acc. to EC2)									
Minimum embedment depth	[kN]	6.88	10.8	15.5	21.1	27.5	43.0	67.2	101.9
Maximum embedment depth	[kN]	6.88	10.8	15.5	21.1	27.5	43.0	67.2	110.1
$f_{uk} = 620$ (e.g. G-60 acc. to ASTM 615)									
Minimum embedment depth	[kN]	7.42	11.6	16.7	22.7	29.7	46.4	72.5	101.9
Maximum embedment depth	[kN]	7.42	11.6	16.7	22.7	29.7	46.4	72.5	118.7

Product commercial data

Product Code	Volume [ml]	Quantity [pcs]			Weight [kg]			Bar Code	Shelf Life [month]
		Box	Outer	Pallet	Box	Outer	Pallet		
R-CFS+RV200-4	300	4	32	384	2.44	7.32	263.52	5906675205830	18
R-CFS+RV200W-4	300	4	32	384	2.44	7.32	263.52	5906675375762	12
R-CFS+RV200S-4	300	4	32	384	2.44	7.32	263.52	5906675201375	12
R-CFS+RV200-600-8	600	8	-	288	8.30	8.30	298.8	5906675119045	18
R-CFS+RV200TW-600-8	600	8	-	288	8.30	8.30	298.8	5906675328270	12

RV200 with Post-Installed Rebar (CFS+)

High performance vinylester resin approved for use with post-installed rebar connections - Cartridge Free System (CFS+)



Approvals and Reports

- ETA-12/0319



Installation movie

Product overview

Features and benefits

- Approved for use with post-installed rebar in concrete
- Suitable for most solid substrates including overhead applications
- Very high load capacity
- Suitable for use in low temperatures (down to -20° C for winter option) enables use throughout the year; Winter version can be used in warmer temperatures for faster curing
- Unique soft foil pack for less waste
- Effortless extrusion due to patented self-opening system with manual or pneumatic dispenser guns
- Suitable for use in dry and wet substrates as well as holes and substrates covered with water
- Rapid bonding time enables quick execution of works
- Suitable for multiple use. Partly used cartridge can continue to be used after fitting new nozzle

Applications

- Shear dowel connections
- Foundation wall connections
- Post-installed rebar connections
- Rebar
- Rebar dowelling
- Rebar missed-outs
- Strengthening reinforced concrete structures
- Starter bars
- Expansion of the stairs
- Renovation and modernization of bridges

Base materials

Approved for use in:

- Concrete C12/15-C50/60

Installation guide

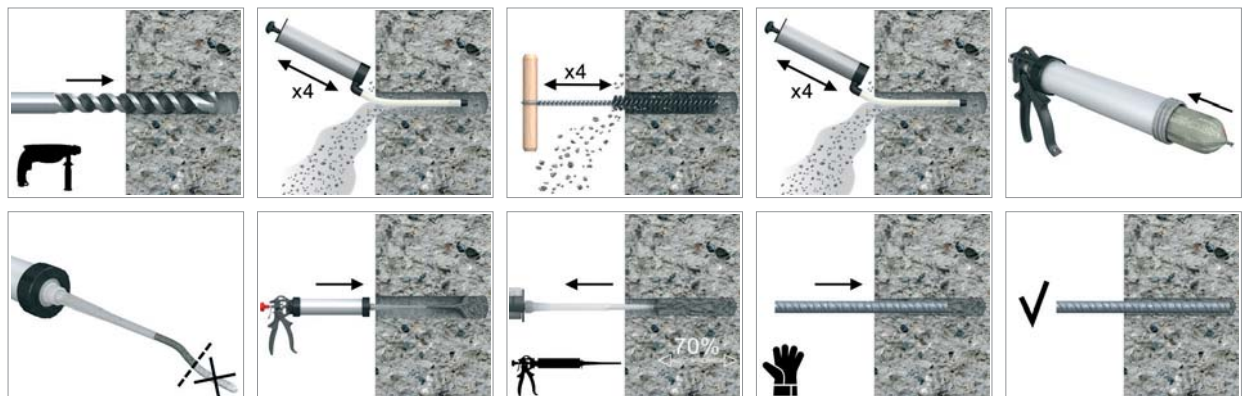

Installation guide (cont.)

1. Drill hole to the required diameter and depth for rebar size being used.
2. Clean the hole thoroughly with brush and hand pump at least four times before installation.
3. Insert foil into gun and attach nozzle.
4. Dispense to waste until even colour is obtained.
5. Insert the mixer nozzle to the bottom of the drill hole and inject resin, slowly withdrawing the nozzle as the hole is filled to 70% of its depth.
6. Immediately insert rebar, slowly and with slight twisting motion. Remove any excess resin around the hole before it sets and leave it undisturbed until the curing time elapses.

Product information

Product Code	Resin	Description / Resin Type	Volume
			[ml]
R-CFS+RV200-4	RV200	Styrene Free Vinylester Resin	300
R-CFS+RV200-600-8			600

Installation data

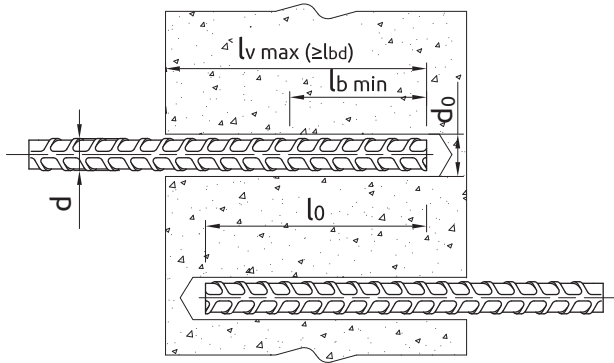

POST INSTALLED REBARS

Size		Ø8	Ø10	Ø12	Ø14	Ø16	Ø20	Ø25	Ø28	Ø30	Ø32
Rebar diameter	d_s [mm]	8	10	12	14	16	20	25	28	30	32
Hole diameter in substrate	d_o [mm]	12	14	16	18	20	25	30	35	35	40
Brush diameter	[mm]	14	16	18	20	22	27	32	37	37	42
Min. anchorage length	$l_{b,min}$ [mm]	115	145	170	200	230	285	355	400	420	455
Min. lap length (overlap splice)	$l_{o,min}$ [mm]	200	215	255	300	340	430	540	600	640	480
Max. anchorage length	$l_{v,max}$ [mm]	400	500	600	700	800	1000	1000	1000	1000	1000

Minimum working and curing time

Resin temperature	Concrete temperature	Working time	Curing time*
[°C]	[°C]	[min]	[min]
5	-5	60	360
5	0	40	180
5	5	20	120
10	10	12	80
15	15	8	60
20	20	5	45
25	30	2	20
25	40	0.5	10

*For wet concrete the curing time must be doubled

Mechanical properties

POST INSTALLED REBARS

Size			Ø8	Ø10	Ø12	Ø14	Ø16	Ø20	Ø25	Ø28	Ø30	Ø32
f_{yk} = 410 (e.g. 34GS acc. to EC2)												
Nominal yield strength - tension	f _{yk}	[N/mm ²]	410	410	410	410	410	410	410	410	410	410
Cross sectional area - tension	A _s	[mm ²]	50.3	78.5	113.1	153.9	201.1	314.2	490.9	615.8	706.9	804.2
f_{yk} = 420 (e.g. G-60 acc. to ASTM 615)												
Nominal yield strength - tension	f _{yk}	[N/mm ²]	420	420	420	420	420	420	420	420	420	420
Cross sectional area - tension	A _s	[mm ²]	50.3	78.5	113.1	153.9	201.1	314.2	490.9	615.8	706.9	804.2
f_{yk} = 460 (e.g. 460 B acc. to BS 4449)												
Nominal yield strength - tension	f _{yk}	[N/mm ²]	460	460	460	460	460	460	460	460	460	460
Cross sectional area - tension	A _s	[mm ²]	50.3	78.5	113.1	153.9	201.1	314.2	490.9	615.8	706.9	804.2
f_{yk} = 500 (e.g. B 500 SP acc. to EC2; 500 B acc. to BS 4449; B 500 B acc. to SS 560)												
Nominal yield strength - tension	f _{yk}	[N/mm ²]	500	500	500	500	500	500	500	500	500	500
Cross sectional area - tension	A _s	[mm ²]	50.3	78.5	113.1	153.9	201.1	314.2	490.9	615.8	706.9	804.2
f_{yk} = 600 (e.g. B 600 B acc. to SS 560)												
Nominal yield strength - tension	f _{yk}	[N/mm ²]	600	600	600	600	600	600	600	600	600	600
Cross sectional area - tension	A _s	[mm ²]	50.3	78.5	113.1	153.9	201.1	314.2	490.9	615.8	706.9	804.2

Basic performance data

ANCHORAGES – DESIGN RESISTANCE – CONCRETE C20/25, NOMINAL YIELD STRENGTH FOR TENSION - f _{yk} = 410 [N/mm ²]																										
l _{bd} [mm]	d _s [mm]	100	120	140	160	180	200	230	260	290	320	350	400	450	500	550	600	650	700	750	800	850	900	950	1000	Steel failure
		8	5,8	6,9	8,1	9,2	10,4	11,6	13,3	15,0	16,8	17,9	17,9	17,9	-	-	-	-	-	-	-	-	-	-	-	-
10	-	8,7	10,1	11,6	13,0	14,5	16,6	18,8	21,0	23,1	25,3	28,0	28,0	28,0	-	-	-	-	-	-	-	-	-	-	-	28,0
12	-	-	12,1	13,9	15,6	17,3	19,9	22,5	25,1	27,7	30,3	34,7	39,0	40,3	40,3	40,3	-	-	-	-	-	-	-	-	-	40,3
14	-	-	-	-	18,2	20,2	23,3	26,3	29,3	32,4	35,4	40,5	45,5	50,6	54,9	54,9	54,9	54,9	-	-	-	-	-	-	-	54,9
16	-	-	-	-	-	23,1	26,6	30,1	33,5	37,0	40,5	46,2	52,0	57,8	63,6	69,4	71,7	71,7	71,7	71,7	-	-	-	-	-	71,7
20	-	-	-	-	-	-	-	37,6	41,9	46,2	50,6	57,8	65,0	72,3	79,5	86,7	93,9	101,2	108,4	112,0	112,0	112,0	112,0	112,0	112,0	112,0
25	-	-	-	-	-	-	-	-	-	57,8	63,2	72,3	81,3	90,3	99,4	108,4	117,4	126,4	135,5	144,5	153,5	162,6	171,6	175,0	175,0	175,0
28	-	-	-	-	-	-	-	-	-	-	70,8	80,9	91,0	101,2	111,3	121,4	131,5	141,6	151,7	161,9	172,0	182,1	192,2	202,3	219,5	219,5
30	-	-	-	-	-	-	-	-	-	-	75,9	86,7	97,5	108,4	119,2	130,1	140,9	151,7	162,6	173,4	184,3	195,1	205,9	216,8	252,0	252,0
32	-	-	-	-	-	-	-	-	-	-	-	92,5	104,0	115,6	127,2	138,7	150,3	161,9	173,4	185,0	196,5	208,1	219,7	231,2	286,7	286,7

ANCHORAGES – DESIGN RESISTANCE – CONCRETE C50/60, NOMINAL YIELD STRENGTH FOR TENSION - f _{yk} = 410 [N/mm ²]																										
l _{bd} [mm]	d _s [mm]	100	120	140	160	180	200	225	250	275	300	350	400	450	500	550	600	650	700	750	800	850	900	950	1000	Steel failure
		8	10,8	13,0	15,1	17,3	17,9	17,9	17,9	17,9	17,9	17,9	17,9	17,9	-	-	-	-	-	-	-	-	-	-	-	-
10	13,5	16,2	18,9	21,6	24,3	27,0	28,0	28,0	28,0	28,0	28,0	28,0	28,0	28,0	-	-	-	-	-	-	-	-	-	-	-	28,0
12	-	19,5	22,7	25,9	29,2	32,4	36,5	40,3	40,3	40,3	40,3	40,3	40,3	40,3	40,3	40,3	-	-	-	-	-	-	-	-	40,3	
14	-	-	26,5	30,3	34,0	37,8	42,6	47,3	52,0	54,9	54,9	54,9	54,9	54,9	54,9	54,9	54,9	54,9	54,9	-	-	-	-	-	54,9	
16	-	-	-	32,2	36,2	40,2	45,2	50,3	55,3	60,3	70,4	71,7	71,7	71,7	71,7	71,7	71,7	71,7	71,7	71,7	-	-	-	-	-	71,7
20	-	-	-	-	-	46,5	52,3	58,1	63,9	69,7	81,4	93,0	104,6	112,0	112,0	112,0	112,0	112,0	112,0	112,0	112,0	112,0	112,0	112,0	112,0	112,0
25	-	-	-	-	-	-	-	58,9	64,8	70,7	82,5	94,2	106,0	117,8	129,6	141,4	153,2	164,9	175,0	175,0	175,0	175,0	175,0	175,0	175,0	175,0
28	-	-	-	-	-	-	-	-	-	79,2	92,4	105,6	118,8	131,9	145,1	158,3	171,5	184,7	197,9	211,1	219,5	219,5	219,5	219,5	219,5	219,5
30	-	-	-	-	-	-	-	-	-	76,3	89,1	101,8	114,5	127,2	140,0	152,7	165,4	178,1	190,9	203,6	216,3	229,0	241,7	252,0	252,0	252,0
32	-	-	-	-	-	-	-	-	-	-	95,0	108,6	122,1	135,7	149,3	162,9	176,4	190,0	203,6	217,1	230,7	244,3	257,9	271,4	286,7	286,7

Basic performance data (cont.)

OVERLAP SPLICE – DESIGN RESISTANCE – CONCRETE C20/25, NOMINAL YIELD STRENGTH FOR TENSION - $f_{yk} = 410$ [N/mm ²]																										
l_{bd} [mm]	d_s [mm]	200	220	240	260	280	300	325	350	375	400	425	450	475	500	550	600	650	700	750	800	850	900	950	1000	Steel failure
8		11,6	12,7	13,9	15,0	16,2	17,3	17,9	17,9	17,9	-	-	-	-	-	-	-	-	-	-	-	-	-	-	-	17,9
10		14,5	15,9	17,3	18,8	20,2	21,7	23,5	25,3	27,1	28,0	28,0	28,0	28,0	-	-	-	-	-	-	-	-	-	-	-	28,0
12		-	19,1	20,8	22,5	24,3	26,0	28,2	30,3	32,5	34,7	36,9	39,0	40,3	40,3	40,3	-	-	-	-	-	-	-	-	-	40,3
14		-	-	-	26,3	28,3	30,3	32,9	35,4	37,9	40,5	43,0	45,5	48,1	50,6	54,9	54,9	54,9	54,9	-	-	-	-	-	-	54,9
16		-	-	-	-	32,4	34,7	37,6	40,5	43,4	46,2	49,1	52,0	54,9	57,8	63,6	69,4	71,7	71,7	71,7	71,7	-	-	-	-	71,7
20		-	-	-	-	-	-	-	50,6	54,2	57,8	61,4	65,0	68,6	72,3	79,5	86,7	93,9	101,2	108,4	112,0	112,0	112,0	112,0	112,0	112,0
25		-	-	-	-	-	-	-	-	-	-	-	81,3	85,8	90,3	99,4	108,4	117,4	126,4	135,5	144,5	153,5	162,6	171,6	175,0	175,0
28		-	-	-	-	-	-	-	-	-	-	-	-	-	101,2	111,3	121,4	131,5	141,6	151,7	161,9	172,0	182,1	192,2	202,3	219,5
30		-	-	-	-	-	-	-	-	-	-	-	-	-	-	119,2	130,1	140,9	151,7	162,6	173,4	184,3	195,1	205,9	216,8	252,0
32		-	-	-	-	-	-	-	-	-	-	-	-	-	-	-	138,7	150,3	161,9	173,4	185,0	196,5	208,1	219,7	231,2	286,7

OVERLAP SPLICE – DESIGN RESISTANCE – CONCRETE C50/60, NOMINAL YIELD STRENGTH FOR TENSION - $f_{yk} = 410$ [N/mm ²]																										
l_{bd} [mm]	d_s [mm]	200	220	240	260	280	300	325	350	375	400	425	450	475	500	550	600	650	700	750	800	850	900	950	1000	Steel failure
8		17,9	17,9	17,9	17,9	17,9	17,9	17,9	17,9	17,9	-	-	-	-	-	-	-	-	-	-	-	-	-	-	-	17,9
10		27,0	28,0	28,0	28,0	28,0	28,0	28,0	28,0	28,0	28,0	28,0	28,0	28,0	-	-	-	-	-	-	-	-	-	-	-	28,0
12		32,4	35,7	38,9	40,3	40,3	40,3	40,3	40,3	40,3	40,3	40,3	40,3	40,3	40,3	40,3	-	-	-	-	-	-	-	-	-	40,3
14		-	41,6	45,4	49,2	53,0	54,9	54,9	54,9	54,9	54,9	54,9	54,9	54,9	54,9	54,9	54,9	54,9	54,9	-	-	-	-	-	-	54,9
16		-	-	48,3	52,3	56,3	60,3	65,3	70,4	71,7	71,7	71,7	71,7	71,7	71,7	71,7	71,7	71,7	71,7	71,7	-	-	-	-	-	71,7
20		-	-	-	-	-	69,7	75,6	81,4	87,2	93,0	98,8	104,6	110,4	112,0	112,0	112,0	112,0	112,0	112,0	112,0	112,0	112,0	112,0	112,0	112,0
25		-	-	-	-	-	-	-	-	88,4	94,2	100,1	106,0	111,9	117,8	129,6	141,4	153,2	164,9	175,0	175,0	175,0	175,0	175,0	175,0	175,0
28		-	-	-	-	-	-	-	-	-	-	112,2	118,8	125,3	131,9	145,1	158,3	171,5	184,7	197,9	211,1	219,5	219,5	219,5	219,5	219,5
30		-	-	-	-	-	-	-	-	-	-	-	114,5	120,9	127,2	140,0	152,7	165,4	178,1	190,9	203,6	216,3	229,0	241,7	252,0	252,0
32		-	-	-	-	-	-	-	-	-	-	-	-	-	135,7	149,3	162,9	176,4	190,0	203,6	217,1	230,7	244,3	257,9	271,4	286,7

ANCHORAGES – DESIGN RESISTANCE – CONCRETE C20/25, NOMINAL YIELD STRENGTH FOR TENSION - $f_{yk} = 420$ [N/mm ²]																										
l_{bd} [mm]	d_s [mm]	100	120	140	160	180	200	230	260	290	320	350	400	450	500	550	600	650	700	750	800	850	900	950	1000	Steel failure
8		5,8	6,9	8,1	9,2	10,4	11,6	13,3	15,0	16,8	18,4	18,4	18,4	-	-	-	-	-	-	-	-	-	-	-	-	18,4
10		-	8,7	10,1	11,6	13,0	14,5	16,6	18,8	21,0	23,1	25,3	28,7	28,7	28,7	-	-	-	-	-	-	-	-	-	-	28,7
12		-	-	-	13,9	15,6	17,3	19,9	22,5	25,1	27,7	30,3	34,7	39,0	41,3	41,3	41,3	-	-	-	-	-	-	-	-	41,3
14		-	-	-	-	18,2	20,2	23,3	26,3	29,3	32,4	35,4	40,5	45,5	50,6	55,6	56,2	56,2	56,2	-	-	-	-	-	-	56,2
16		-	-	-	-	-	23,1	26,6	30,1	33,5	37,0	40,5	46,2	52,0	57,8	63,6	69,4	73,4	73,4	73,4	73,4	-	-	-	-	73,4
20		-	-	-	-	-	-	-	37,6	41,9	46,2	50,6	57,8	65,0	72,3	79,5	86,7	93,9	101,2	108,4	114,8	114,8	114,8	114,8	114,8	114,8
25		-	-	-	-	-	-	-	-	-	57,8	63,2	72,3	81,3	90,3	99,4	108,4	117,4	126,4	135,5	144,5	153,5	162,6	171,6	179,3	179,3
28		-	-	-	-	-	-	-	-	-	-	70,8	80,9	91,0	101,2	111,3	121,4	131,5	141,6	151,7	161,9	172,0	182,1	192,2	202,3	224,9
30		-	-	-	-	-	-	-	-	-	-	-	86,7	97,5	108,4	119,2	130,1	140,9	151,7	162,6	173,4	184,3	195,1	205,9	216,8	258,2
32		-	-	-	-	-	-	-	-	-	-	-	92,5	104,0	115,6	127,2	138,7	150,3	161,9	173,4	185,0	196,5	208,1	219,7	231,2	293,7

ANCHORAGES – DESIGN RESISTANCE – CONCRETE C50/60, NOMINAL YIELD STRENGTH FOR TENSION - $f_{yk} = 420$ [N/mm ²]																										
l_{bd} [mm]	d_s [mm]	100	120	140	160	180	200	230	260	290	320	350	400	450	500	550	600	650	700	750	800	850	900	950	1000	Steel failure
8		10,8	13,0	15,1	17,3	18,4	18,4	18,4	18,4	18,4	18,4	18,4	18,4	-	-	-	-	-	-	-	-	-	-	-	-	18,4
10		13,5	16,2	18,9	21,6	24,3	27,0	28,7	28,7	28,7	28,7	28,7	28,7	28,7	28,7	-	-	-	-	-	-	-	-	-	-	28,7
12		-	19,5	22,7	25,9	29,2	32,4	37,3	41,3	41,3	41,3	41,3	41,3	41,3	41,3	41,3	41,3	-	-	-	-	-	-	-	-	41,3
14		-	-	26,5	30,3	34,0	37,8	43,5	49,2	54,8	56,2	56,2	56,2	56,2	56,2	56,2	56,2	56,2	56,2	-	-	-	-	-	-	56,2
16		-	-	-	32,2	36,2	40,2	46,2	52,3	58,3	64,3	70,4	73,4	73,4	73,4	73,4	73,4	73,4	73,4	73,4	73,4	-	-	-	-	73,4
20		-	-	-	-	-	46,5	53,5	60,4	67,4	74,4	81,4	93,0	104,6	114,8	114,8	114,8	114,8	114,8	114,8	114,8	114,8	114,8	114,8	114,8	114,8
25		-	-	-	-	-	-	-	61,3	68,3	75,4	82,5	94,2	106,0	117,8	129,6	141,4	153,2	164,9	176,7	179,3	179,3	179,3	179,3	179,3	179,3
28		-	-	-	-	-	-	-	-	76,5	84,4	92,4	105,6	118,8	131,9	145,1	158,3	171,5	184,7	197,9	211,1	224,3	224,9	224,9	224,9	224,9
30		-	-	-	-	-	-	-	-	-	81,4	89,1	101,8	114,5	127,2	140,0	152,7	165,4	178,1	190,9	203,6	216,3	229,0	241,7	254,5	258,2
32		-	-	-	-	-	-	-	-	-	-	95,0	108,6	122,1	135,7	149,3	162,9	176,4	190,0	203,6	217,1	230,7	244,3	257,9	271,4	293,7

All products listed in this publication are branded and distributed with RAWLPLUG® or RAWL® trademarks.

Basic performance data (cont.)

OVERLAP SPLICE – DESIGN RESISTANCE – CONCRETE C20/25, NOMINAL YIELD STRENGTH FOR TENSION - $f_{yk} = 420$ [N/mm ²]																									
$\frac{l_{bd}}{d_s}$	200	220	240	260	280	300	325	350	375	400	425	450	475	500	550	600	650	700	750	800	850	900	950	1000	Steel failure
8	11,6	12,7	13,9	15,0	16,2	17,3	18,4	18,4	18,4	18,4	-	-	-	-	-	-	-	-	-	-	-	-	-	-	18,4
10	14,5	15,9	17,3	18,8	20,2	21,7	23,5	25,3	27,1	28,7	28,7	28,7	28,7	28,7	-	-	-	-	-	-	-	-	-	-	28,7
12	-	19,1	20,8	22,5	24,3	26,0	28,2	30,3	32,5	34,7	36,9	39,0	41,2	41,3	41,3	41,3	-	-	-	-	-	-	-	-	41,3
14	-	-	-	26,3	28,3	30,3	32,9	35,4	37,9	40,5	43,0	45,5	48,1	50,6	55,6	56,2	56,2	56,2	-	-	-	-	-	-	56,2
16	-	-	-	-	-	34,7	37,6	40,5	43,4	46,2	49,1	52,0	54,9	57,8	63,6	69,4	73,4	73,4	73,4	73,4	-	-	-	-	73,4
20	-	-	-	-	-	-	-	-	54,2	57,8	61,4	65,0	68,6	72,3	79,5	86,7	93,9	101,2	108,4	114,8	114,8	114,8	114,8	114,8	114,8
25	-	-	-	-	-	-	-	-	-	-	-	81,3	85,8	90,3	99,4	108,4	117,4	126,4	135,5	144,5	153,5	162,6	171,6	179,3	179,3
28	-	-	-	-	-	-	-	-	-	-	-	-	-	-	111,3	121,4	131,5	141,6	151,7	161,9	172,0	182,1	192,2	202,3	224,9
30	-	-	-	-	-	-	-	-	-	-	-	-	-	-	119,2	130,1	140,9	151,7	162,6	173,4	184,3	195,1	205,9	216,8	258,2
32	-	-	-	-	-	-	-	-	-	-	-	-	-	-	-	138,7	150,3	161,9	173,4	185,0	196,5	208,1	219,7	231,2	293,7

OVERLAP SPLICE – DESIGN RESISTANCE – CONCRETE C50/60, NOMINAL YIELD STRENGTH FOR TENSION - $f_{yk} = 420$ [N/mm ²]																									
$\frac{l_{bd}}{d_s}$	200	220	240	260	280	300	325	350	375	400	425	450	475	500	550	600	650	700	750	800	850	900	950	1000	Steel failure
8	18,4	18,4	18,4	18,4	18,4	18,4	18,4	18,4	18,4	18,4	-	-	-	-	-	-	-	-	-	-	-	-	-	-	18,4
10	27,0	28,7	28,7	28,7	28,7	28,7	28,7	28,7	28,7	28,7	28,7	28,7	28,7	28,7	-	-	-	-	-	-	-	-	-	-	28,7
12	32,4	35,7	38,9	41,3	41,3	41,3	41,3	41,3	41,3	41,3	41,3	41,3	41,3	41,3	41,3	41,3	-	-	-	-	-	-	-	-	41,3
14	-	41,6	45,4	49,2	53,0	56,2	56,2	56,2	56,2	56,2	56,2	56,2	56,2	56,2	56,2	56,2	56,2	56,2	-	-	-	-	-	-	56,2
16	-	-	48,3	52,3	56,3	60,3	65,3	70,4	73,4	73,4	73,4	73,4	73,4	73,4	73,4	73,4	73,4	73,4	73,4	73,4	-	-	-	-	73,4
20	-	-	-	-	-	69,7	75,6	81,4	87,2	93,0	98,8	104,6	110,4	114,8	114,8	114,8	114,8	114,8	114,8	114,8	114,8	114,8	114,8	114,8	114,8
25	-	-	-	-	-	-	-	-	88,4	94,2	100,1	106,0	111,9	117,8	129,6	141,4	153,2	164,9	176,7	179,3	179,3	179,3	179,3	179,3	179,3
28	-	-	-	-	-	-	-	-	-	112,2	118,8	125,3	131,9	145,1	158,3	171,5	184,7	197,9	211,1	224,3	224,9	224,9	224,9	224,9	224,9
30	-	-	-	-	-	-	-	-	-	-	120,9	127,2	140,0	152,7	165,4	178,1	190,9	203,6	216,3	229,0	241,7	254,5	254,5	254,5	258,2
32	-	-	-	-	-	-	-	-	-	-	-	-	-	135,7	149,3	162,9	176,4	190,0	203,6	217,1	230,7	244,3	257,9	271,4	293,7

ANCHORAGES – DESIGN RESISTANCE – CONCRETE C20/25, NOMINAL YIELD STRENGTH FOR TENSION - $f_{yk} = 460$ [N/mm ²]																									
$\frac{l_{bd}}{d_s}$	100	120	140	160	180	200	230	260	290	320	350	400	450	500	550	600	650	700	750	800	850	900	950	1000	Steel failure
8	-	6,9	8,1	9,2	10,4	11,6	13,3	15,0	16,8	18,5	20,1	20,1	-	-	-	-	-	-	-	-	-	-	-	-	20,1
10	-	-	10,1	11,6	13,0	14,5	16,6	18,8	21,0	23,1	25,3	28,9	31,4	31,4	-	-	-	-	-	-	-	-	-	-	31,4
12	-	-	-	13,9	15,6	17,3	19,9	22,5	25,1	27,7	30,3	34,7	39,0	43,4	45,2	45,2	-	-	-	-	-	-	-	-	45,2
14	-	-	-	-	-	20,2	23,3	26,3	29,3	32,4	35,4	40,5	45,5	50,6	55,6	60,7	61,6	61,6	-	-	-	-	-	-	61,6
16	-	-	-	-	-	-	26,6	30,1	33,5	37,0	40,5	46,2	52,0	57,8	63,6	69,4	75,1	80,4	80,4	80,4	-	-	-	-	80,4
20	-	-	-	-	-	-	-	-	41,9	46,2	50,6	57,8	65,0	72,3	79,5	86,7	93,9	101,2	108,4	115,6	122,8	125,7	125,7	125,7	125,7
25	-	-	-	-	-	-	-	-	-	63,2	72,3	81,3	90,3	99,4	108,4	117,4	126,4	135,5	144,5	153,5	162,6	171,6	180,6	180,6	196,4
28	-	-	-	-	-	-	-	-	-	-	80,9	91,0	101,2	111,3	121,4	131,5	141,6	151,7	161,9	172,0	182,1	192,2	202,3	202,3	246,3
30	-	-	-	-	-	-	-	-	-	-	-	86,7	97,5	108,4	119,2	130,1	140,9	151,7	162,6	173,4	184,3	195,1	205,9	216,8	282,7
32	-	-	-	-	-	-	-	-	-	-	-	-	104,0	115,6	127,2	138,7	150,3	161,9	173,4	185,0	196,5	208,1	219,7	231,2	321,7

ANCHORAGES – DESIGN RESISTANCE – CONCRETE C50/60, NOMINAL YIELD STRENGTH FOR TENSION - $f_{yk} = 460$ [N/mm ²]																									
$\frac{l_{bd}}{d_s}$	100	120	140	160	180	200	230	260	290	320	350	400	450	500	550	600	650	700	750	800	850	900	950	1000	Steel failure
8	10,8	13,0	15,1	17,3	19,5	20,1	20,1	20,1	20,1	20,1	20,1	-	-	-	-	-	-	-	-	-	-	-	-	-	20,1
10	13,5	16,2	18,9	21,6	24,3	27,0	31,1	31,4	31,4	31,4	31,4	31,4	31,4	31,4	-	-	-	-	-	-	-	-	-	-	31,4
12	-	19,5	22,7	25,9	29,2	32,4	37,3	42,1	45,2	45,2	45,2	45,2	45,2	45,2	45,2	45,2	-	-	-	-	-	-	-	-	45,2
14	-	-	26,5	30,3	34,0	37,8	43,5	49,2	54,8	60,5	61,6	61,6	61,6	61,6	61,6	61,6	61,6	61,6	-	-	-	-	-	-	61,6
16	-	-	-	32,2	36,2	40,2	46,2	52,3	58,3	64,3	70,4	80,4	80,4	80,4	80,4	80,4	80,4	80,4	80,4	80,4	-	-	-	-	80,4
20	-	-	-	-	-	46,5	53,5	60,4	67,4	74,4	81,4	93,0	104,6	116,2	125,7	125,7	125,7	125,7	125,7	125,7	125,7	125,7	125,7	125,7	125,7
25	-	-	-	-	-	-	-	61,3	68,3	75,4	82,5	94,2	106,0	117,8	129,6	141,4	153,2	164,9	176,7	188,5	196,4	196,4	196,4	196,4	196,4
28	-	-	-	-	-	-	-	-	76,5	84,4	92,4	105,6	118,8	131,9	145,1	158,3	171,5	184,7	197,9	211,1	224,3	237,5	246,3	246,3	246,3
30	-	-	-	-	-	-	-	-	-	89,1	101,8	114,5	127,2	140,0	152,7	165,4	178,1	190,9	203,6	216,3	229,0	241,7	254,5	254,5	282,7
32	-	-	-	-	-	-	-	-	-	-	108,6	122,1	135,7	149,3	162,9	176,4	190,0	203,6	217,1	230,7	244,3	257,9	271,4	271,4	321,7

Basic performance data (cont.)

OVERLAP SPLICE – DESIGN RESISTANCE – CONCRETE C20/25, NOMINAL YIELD STRENGTH FOR TENSION - $f_{yk} = 460$ [N/mm ²]																										
$\frac{l_{bd}}{d_s}$	d_s	200	220	240	260	280	300	325	350	375	400	425	450	475	500	550	600	650	700	750	800	850	900	950	1000	Steel failure
8		11,6	12,7	13,9	15,0	16,2	17,3	18,8	20,1	20,1	-	-	-	-	-	-	-	-	-	-	-	-	-	-	-	20,1
10		14,5	15,9	17,3	18,8	20,2	21,7	23,5	25,3	27,1	28,9	30,7	31,4	31,4	31,4	-	-	-	-	-	-	-	-	-	-	31,4
12		-	-	20,8	22,5	24,3	26,0	28,2	30,3	32,5	34,7	36,9	39,0	41,2	43,4	45,2	45,2	-	-	-	-	-	-	-	-	45,2
14		-	-	-	-	28,3	30,3	32,9	35,4	37,9	40,5	43,0	45,5	48,1	50,6	55,6	60,7	61,6	61,6	-	-	-	-	-	-	61,6
16		-	-	-	-	-	-	37,6	40,5	43,4	46,2	49,1	52,0	54,9	57,8	63,6	69,4	75,1	80,4	80,4	80,4	-	-	-	-	80,4
20		-	-	-	-	-	-	-	-	-	57,8	61,4	65,0	68,6	72,3	79,5	86,7	93,9	101,2	108,4	115,6	122,8	125,7	125,7	125,7	125,7
25		-	-	-	-	-	-	-	-	-	-	-	-	-	90,3	99,4	108,4	117,4	126,4	135,5	144,5	153,5	162,6	171,6	180,6	196,4
28		-	-	-	-	-	-	-	-	-	-	-	-	-	-	111,3	121,4	131,5	141,6	151,7	161,9	172,0	182,1	192,2	202,3	246,3
30		-	-	-	-	-	-	-	-	-	-	-	-	-	-	-	130,1	140,9	151,7	162,6	173,4	184,3	195,1	205,9	216,8	282,7
32		-	-	-	-	-	-	-	-	-	-	-	-	-	-	-	-	150,3	161,9	173,4	185,0	196,5	208,1	219,7	231,2	321,7

OVERLAP SPLICE – DESIGN RESISTANCE – CONCRETE C50/60, NOMINAL YIELD STRENGTH FOR TENSION - $f_{yk} = 460$ [N/mm ²]																										
$\frac{l_{bd}}{d_s}$	d_s	200	220	240	260	280	300	325	350	375	400	425	450	475	500	550	600	650	700	750	800	850	900	950	1000	Steel failure
8		20,1	20,1	20,1	20,1	20,1	20,1	20,1	20,1	20,1	-	-	-	-	-	-	-	-	-	-	-	-	-	-	-	20,1
10		27,0	29,7	31,4	31,4	31,4	31,4	31,4	31,4	31,4	31,4	31,4	31,4	31,4	31,4	-	-	-	-	-	-	-	-	-	-	31,4
12		32,4	35,7	38,9	42,1	45,2	45,2	45,2	45,2	45,2	45,2	45,2	45,2	45,2	45,2	45,2	45,2	-	-	-	-	-	-	-	-	45,2
14		-	41,6	45,4	49,2	53,0	56,7	61,5	61,6	61,6	61,6	61,6	61,6	61,6	61,6	61,6	61,6	61,6	61,6	-	-	-	-	-	-	61,6
16		-	-	48,3	52,3	56,3	60,3	65,3	70,4	75,4	80,4	80,4	80,4	80,4	80,4	80,4	80,4	80,4	80,4	80,4	80,4	-	-	-	-	80,4
20		-	-	-	-	-	69,7	75,6	81,4	87,2	93,0	98,8	104,6	110,4	116,2	125,7	125,7	125,7	125,7	125,7	125,7	125,7	125,7	125,7	125,7	125,7
25		-	-	-	-	-	-	-	-	88,4	94,2	100,1	106,0	111,9	117,8	129,6	141,4	153,2	164,9	176,7	188,5	196,4	196,4	196,4	196,4	196,4
28		-	-	-	-	-	-	-	-	-	112,2	118,8	125,3	131,9	145,1	158,3	171,5	184,7	197,9	211,1	224,3	237,5	246,3	246,3	246,3	246,3
30		-	-	-	-	-	-	-	-	-	-	-	-	-	127,2	140,0	152,7	165,4	178,1	190,9	203,6	216,3	229,0	241,7	254,5	282,7
32		-	-	-	-	-	-	-	-	-	-	-	-	-	-	149,3	162,9	176,4	190,0	203,6	217,1	230,7	244,3	257,9	271,4	321,7

ANCHORAGES – DESIGN RESISTANCE – CONCRETE C20/25, NOMINAL YIELD STRENGTH FOR TENSION - $f_{yk} = 500$ [N/mm ²]																										
$\frac{l_{bd}}{d_s}$	d_s	100	120	140	160	180	200	230	260	290	320	350	400	450	500	550	600	650	700	750	800	850	900	950	1000	Steel failure
8		-	6,9	8,1	9,2	10,4	11,6	13,3	15,0	16,8	18,5	20,2	21,9	-	-	-	-	-	-	-	-	-	-	-	-	21,9
10		-	-	-	11,6	13,0	14,5	16,6	18,8	21,0	23,1	25,3	28,9	32,5	34,1	-	-	-	-	-	-	-	-	-	-	34,1
12		-	-	-	-	15,6	17,3	19,9	22,5	25,1	27,7	30,3	34,7	39,0	43,4	47,7	49,2	-	-	-	-	-	-	-	-	49,2
14		-	-	-	-	-	20,2	23,3	26,3	29,3	32,4	35,4	40,5	45,5	50,6	55,6	60,7	65,8	66,9	-	-	-	-	-	-	66,9
16		-	-	-	-	-	-	26,6	30,1	33,5	37,0	40,5	46,2	52,0	57,8	63,6	69,4	75,1	80,9	86,7	87,4	-	-	-	-	87,4
20		-	-	-	-	-	-	-	-	41,9	46,2	50,6	57,8	65,0	72,3	79,5	86,7	93,9	101,2	108,4	115,6	122,8	130,1	136,6	136,6	136,6
25		-	-	-	-	-	-	-	-	-	-	-	72,3	81,3	90,3	99,4	108,4	117,4	126,4	135,5	144,5	153,5	162,6	171,6	180,6	213,4
28		-	-	-	-	-	-	-	-	-	-	-	80,9	91,0	101,2	111,3	121,4	131,5	141,6	151,7	161,9	172,0	182,1	192,2	202,3	267,7
30		-	-	-	-	-	-	-	-	-	-	-	-	97,5	108,4	119,2	130,1	140,9	151,7	162,6	173,4	184,3	195,1	205,9	216,8	307,3
32		-	-	-	-	-	-	-	-	-	-	-	-	-	115,6	127,2	138,7	150,3	161,9	173,4	185,0	196,5	208,1	219,7	231,2	349,7

ANCHORAGES – DESIGN RESISTANCE – CONCRETE C50/60, NOMINAL YIELD STRENGTH FOR TENSION - $f_{yk} = 500$ [N/mm ²]																										
$\frac{l_{bd}}{d_s}$	d_s	100	120	140	160	180	200	230	260	290	320	350	400	450	500	550	600	650	700	750	800	850	900	950	1000	Steel failure
8		10,8	13,0	15,1	17,3	19,5	21,6	21,9	21,9	21,9	21,9	21,9	21,9	-	-	-	-	-	-	-	-	-	-	-	-	21,9
10		13,5	16,2	18,9	21,6	24,3	27,0	31,1	34,1	34,1	34,1	34,1	34,1	34,1	34,1	-	-	-	-	-	-	-	-	-	-	34,1
12		-	19,5	22,7	25,9	29,2	32,4	37,3	42,1	47,0	49,2	49,2	49,2	49,2	49,2	49,2	49,2	-	-	-	-	-	-	-	-	49,2
14		-	-	26,5	30,3	34,0	37,8	43,5	49,2	54,8	60,5	66,2	66,9	66,9	66,9	66,9	66,9	66,9	66,9	-	-	-	-	-	-	66,9
16		-	-	-	32,2	36,2	40,2	46,2	52,3	58,3	64,3	70,4	80,4	87,4	87,4	87,4	87,4	87,4	87,4	87,4	87,4	-	-	-	-	87,4
20		-	-	-	-	-	46,5	53,5	60,4	67,4	74,4	81,4	93,0	104,6	116,2	127,9	136,6	136,6	136,6	136,6	136,6	136,6	136,6	136,6	136,6	136,6
25		-	-	-	-	-	-	-	-	68,3	75,4	82,5	94,2	106,0	117,8	129,6	141,4	153,2	164,9	176,7	188,5	200,3	212,1	213,4	213,4	213,4
28		-	-	-	-	-	-	-	-	-	84,4	92,4	105,6	118,8	131,9	145,1	158,3	171,5	184,7	197,9	211,1	224,3	237,5	250,7	263,9	267,7
30		-	-	-	-	-	-	-	-	-	-	-	101,8	114,5	127,2	140,0	152,7	165,4	178,1	190,9	203,6	216,3	229,0	241,7	254,5	307,3
32		-	-	-	-	-	-	-	-	-	-	-	108,6	122,1	135,7	149,3	162,9	176,4	190,0	203,6	217,1	230,7	244,3	257,9	271,4	349,7

All products listed in this publication are branded and distributed with RAWLPLUG® or RAWL® trademarks.

Basic performance data (cont.)

OVERLAP SPLICE – DESIGN RESISTANCE – CONCRETE C20/25, NOMINAL YIELD STRENGTH FOR TENSION - $f_{yk} = 500$ [N/mm ²]																										
$\frac{l_{bd}}{d_s}$	d_s [mm]	200	220	240	260	280	300	325	350	375	400	425	450	475	500	550	600	650	700	750	800	850	900	950	1000	Steel failure
		8	11,6	12,7	13,9	15,0	16,2	17,3	18,8	20,2	21,7	21,9	-	-	-	-	-	-	-	-	-	-	-	-	-	-
10	-	15,9	17,3	18,8	20,2	21,7	23,5	25,3	27,1	28,9	30,7	32,5	34,1	34,1	-	-	-	-	-	-	-	-	-	-	-	34,1
12	-	-	-	22,5	24,3	26,0	28,2	30,3	32,5	34,7	36,9	39,0	41,2	43,4	47,7	49,2	-	-	-	-	-	-	-	-	-	49,2
14	-	-	-	-	-	30,3	32,9	35,4	37,9	40,5	43,0	45,5	48,1	50,6	55,6	60,7	65,8	66,9	-	-	-	-	-	-	-	66,9
16	-	-	-	-	-	-	-	40,5	43,4	46,2	49,1	52,0	54,9	57,8	63,6	69,4	75,1	80,9	86,7	87,4	-	-	-	-	-	87,4
20	-	-	-	-	-	-	-	-	-	-	-	65,0	68,6	72,3	79,5	86,7	93,9	101,2	108,4	115,6	122,8	130,1	136,6	136,6	136,6	136,6
25	-	-	-	-	-	-	-	-	-	-	-	-	-	-	99,4	108,4	117,4	126,4	135,5	144,5	153,5	162,6	171,6	180,6	213,4	213,4
28	-	-	-	-	-	-	-	-	-	-	-	-	-	-	-	121,4	131,5	141,6	151,7	161,9	172,0	182,1	192,2	202,3	267,7	267,7
30	-	-	-	-	-	-	-	-	-	-	-	-	-	-	-	-	140,9	151,7	162,6	173,4	184,3	195,1	205,9	216,8	307,3	307,3
32	-	-	-	-	-	-	-	-	-	-	-	-	-	-	-	-	-	161,9	173,4	185,0	196,5	208,1	219,7	231,2	349,7	349,7

OVERLAP SPLICE – DESIGN RESISTANCE – CONCRETE C50/60, NOMINAL YIELD STRENGTH FOR TENSION - $f_{yk} = 500$ [N/mm ²]																										
$\frac{l_{bd}}{d_s}$	d_s [mm]	200	220	240	260	280	300	325	350	375	400	425	450	475	500	550	600	650	700	750	800	850	900	950	1000	Steel failure
		8	21,6	21,9	21,9	21,9	21,9	21,9	21,9	21,9	21,9	21,9	-	-	-	-	-	-	-	-	-	-	-	-	-	-
10	27,0	29,7	32,4	34,1	34,1	34,1	34,1	34,1	34,1	34,1	34,1	34,1	34,1	34,1	-	-	-	-	-	-	-	-	-	-	-	34,1
12	32,4	35,7	38,9	42,1	45,4	48,6	49,2	49,2	49,2	49,2	49,2	49,2	49,2	49,2	49,2	49,2	-	-	-	-	-	-	-	-	-	49,2
14	-	41,6	45,4	49,2	53,0	56,7	61,5	66,2	66,9	66,9	66,9	66,9	66,9	66,9	66,9	66,9	66,9	66,9	66,9	-	-	-	-	-	-	66,9
16	-	-	48,3	52,3	56,3	60,3	65,3	70,4	75,4	80,4	85,5	87,4	87,4	87,4	87,4	87,4	87,4	87,4	87,4	87,4	87,4	-	-	-	-	87,4
20	-	-	-	-	-	69,7	75,6	81,4	87,2	93,0	98,8	104,6	110,4	116,2	127,9	136,6	136,6	136,6	136,6	136,6	136,6	136,6	136,6	136,6	136,6	136,6
25	-	-	-	-	-	-	-	-	-	100,1	106,0	111,9	117,8	129,6	141,4	153,2	164,9	176,7	188,5	200,3	212,1	213,4	213,4	213,4	213,4	213,4
28	-	-	-	-	-	-	-	-	-	-	-	125,3	131,9	145,1	158,3	171,5	184,7	197,9	211,1	224,3	237,5	250,7	263,9	267,7	267,7	267,7
30	-	-	-	-	-	-	-	-	-	-	-	-	-	-	140,0	152,7	165,4	178,1	190,9	203,6	216,3	229,0	241,7	254,5	307,3	307,3
32	-	-	-	-	-	-	-	-	-	-	-	-	-	-	-	162,9	176,4	190,0	203,6	217,1	230,7	244,3	257,9	271,4	349,7	349,7

ANCHORAGES – DESIGN RESISTANCE – CONCRETE C20/25, NOMINAL YIELD STRENGTH FOR TENSION - $f_{yk} = 600$ [N/mm ²]																										
$\frac{l_{bd}}{d_s}$	d_s [mm]	100	120	140	160	180	200	230	260	290	320	350	400	450	500	550	600	650	700	750	800	850	900	950	1000	Steel failure
		8	-	-	8,1	9,2	10,4	11,6	13,3	15,0	16,8	18,5	20,2	23,1	-	-	-	-	-	-	-	-	-	-	-	-
10	-	-	-	-	13,0	14,5	16,6	18,8	21,0	23,1	25,3	28,9	32,5	36,1	-	-	-	-	-	-	-	-	-	-	-	41,0
12	-	-	-	-	-	-	19,9	22,5	25,1	27,7	30,3	34,7	39,0	43,4	47,7	52,0	-	-	-	-	-	-	-	-	-	59,0
14	-	-	-	-	-	-	-	26,3	29,3	32,4	35,4	40,5	45,5	50,6	55,6	60,7	65,8	70,8	-	-	-	-	-	-	-	80,3
16	-	-	-	-	-	-	-	-	33,5	37,0	40,5	46,2	52,0	57,8	63,6	69,4	75,1	80,9	86,7	92,5	-	-	-	-	-	104,9
20	-	-	-	-	-	-	-	-	-	-	50,6	57,8	65,0	72,3	79,5	86,7	93,9	101,2	108,4	115,6	122,8	130,1	137,3	144,5	163,9	163,9
25	-	-	-	-	-	-	-	-	-	-	-	-	81,3	90,3	99,4	108,4	117,4	126,4	135,5	144,5	153,5	162,6	171,6	180,6	256,1	256,1
28	-	-	-	-	-	-	-	-	-	-	-	-	-	-	101,2	111,3	121,4	131,5	141,6	151,7	161,9	172,0	182,1	192,2	321,3	321,3
30	-	-	-	-	-	-	-	-	-	-	-	-	-	-	-	119,2	130,1	140,9	151,7	162,6	173,4	184,3	195,1	205,9	368,8	368,8
32	-	-	-	-	-	-	-	-	-	-	-	-	-	-	-	127,2	138,7	150,3	161,9	173,4	185,0	196,5	208,1	219,7	419,6	419,6

ANCHORAGES – DESIGN RESISTANCE – CONCRETE C50/60, NOMINAL YIELD STRENGTH FOR TENSION - $f_{yk} = 600$ [N/mm ²]																										
$\frac{l_{bd}}{d_s}$	d_s [mm]	100	120	140	160	180	200	230	260	290	320	350	400	450	500	550	600	650	700	750	800	850	900	950	1000	Steel failure
		8	10,8	13,0	15,1	17,3	19,5	21,6	24,9	26,2	26,2	26,2	26,2	-	-	-	-	-	-	-	-	-	-	-	-	-
10	13,5	16,2	18,9	21,6	24,3	27,0	31,1	35,1	39,2	41,0	41,0	41,0	41,0	41,0	-	-	-	-	-	-	-	-	-	-	-	41,0
12	-	19,5	22,7	25,9	29,2	32,4	37,3	42,1	47,0	51,9	56,7	59,0	59,0	59,0	59,0	59,0	-	-	-	-	-	-	-	-	-	59,0
14	-	-	26,5	30,3	34,0	37,8	43,5	49,2	54,8	60,5	66,2	75,6	80,3	80,3	80,3	80,3	80,3	80,3	-	-	-	-	-	-	-	80,3
16	-	-	-	32,2	36,2	40,2	46,2	52,3	58,3	64,3	70,4	80,4	90,5	100,5	104,9	104,9	104,9	104,9	104,9	104,9	104,9	-	-	-	-	104,9
20	-	-	-	-	-	-	53,5	60,4	67,4	74,4	81,4	93,0	104,6	116,2	127,9	139,5	151,1	162,7	163,9	163,9	163,9	163,9	163,9	163,9	163,9	163,9
25	-	-	-	-	-	-	-	-	-	82,5	94,2	106,0	117,8	129,6	141,4	153,2	164,9	176,7	188,5	200,3	212,1	223,8	235,6	256,1	256,1	256,1
28	-	-	-	-	-	-	-	-	-	-	105,6	118,8	131,9	145,1	158,3	171,5	184,7	197,9	211,1	224,3	237,5	250,7	263,9	321,3	321,3	321,3
30	-	-	-	-	-	-	-	-	-	-	-	-	114,5	127,2	140,0	152,7	165,4	178,1	190,9	203,6	216,3	229,0	241,7	254,5	368,8	368,8
32	-	-	-	-	-	-	-	-	-	-	-	-	-	-	135,7	149,3	162,9	176,4	190,0	203,6	217,1	230,7	244,3	257,9	419,6	419,6

Basic performance data (cont.)

OVERLAP SPLICE – DESIGN RESISTANCE – CONCRETE C20/25, NOMINAL YIELD STRENGTH FOR TENSION - $f_{yk} = 600$ [N/mm ²]																									
$\frac{l_{bd}}{d_s}$	100	220	240	260	280	300	325	350	375	400	425	450	475	500	550	600	650	700	750	800	850	900	950	1000	Steel failure
8	-	12,7	13,9	15,0	16,2	17,3	18,8	20,2	21,7	23,1	-	-	-	-	-	-	-	-	-	-	-	-	-	-	26,2
10	-	-	-	18,8	20,2	21,7	23,5	25,3	27,1	28,9	30,7	32,5	34,3	36,1	-	-	-	-	-	-	-	-	-	-	41,0
12	-	-	-	-	-	-	28,2	30,3	32,5	34,7	36,9	39,0	41,2	43,4	47,7	52,0	-	-	-	-	-	-	-	-	59,0
14	-	-	-	-	-	-	-	-	37,9	40,5	43,0	45,5	48,1	50,6	55,6	60,7	65,8	70,8	-	-	-	-	-	-	80,3
16	-	-	-	-	-	-	-	-	-	49,1	52,0	54,9	57,8	63,6	69,4	75,1	80,9	86,7	92,5	-	-	-	-	-	104,9
20	-	-	-	-	-	-	-	-	-	-	-	-	-	-	79,5	86,7	93,9	101,2	108,4	115,6	122,8	130,1	137,3	144,5	163,9
25	-	-	-	-	-	-	-	-	-	-	-	-	-	-	-	117,4	126,4	135,5	144,5	153,5	162,6	171,6	180,6	189,6	256,1
28	-	-	-	-	-	-	-	-	-	-	-	-	-	-	-	-	-	151,7	161,9	172,0	182,1	192,2	202,3	212,4	321,3
30	-	-	-	-	-	-	-	-	-	-	-	-	-	-	-	-	-	-	-	173,4	184,3	195,1	205,9	216,8	368,8
32	-	-	-	-	-	-	-	-	-	-	-	-	-	-	-	-	-	-	-	-	196,5	208,1	219,7	231,2	419,6

OVERLAP SPLICE – DESIGN RESISTANCE – CONCRETE C50/60, NOMINAL YIELD STRENGTH FOR TENSION - $f_{yk} = 600$ [N/mm ²]																									
$\frac{l_{bd}}{d_s}$	200	220	240	260	280	300	325	350	375	400	425	450	475	500	550	600	650	700	750	800	850	900	950	1000	Steel failure
8	21,6	23,8	25,9	26,2	26,2	26,2	26,2	26,2	26,2	26,2	-	-	-	-	-	-	-	-	-	-	-	-	-	-	26,2
10	27,0	29,7	32,4	35,1	37,8	40,5	41,0	41,0	41,0	41,0	41,0	41,0	41,0	41,0	-	-	-	-	-	-	-	-	-	-	41,0
12	32,4	35,7	38,9	42,1	45,4	48,6	52,7	56,7	59,0	59,0	59,0	59,0	59,0	59,0	59,0	-	-	-	-	-	-	-	-	-	59,0
14	-	41,6	45,4	49,2	53,0	56,7	61,5	66,2	70,9	75,6	80,3	80,3	80,3	80,3	80,3	80,3	80,3	80,3	-	-	-	-	-	-	80,3
16	-	-	48,3	52,3	56,3	60,3	65,3	70,4	75,4	80,4	85,5	90,5	95,5	100,5	104,9	104,9	104,9	104,9	104,9	104,9	-	-	-	-	104,9
20	-	-	-	-	-	-	75,6	81,4	87,2	93,0	98,8	104,6	110,4	116,2	127,9	139,5	151,1	162,7	163,9	163,9	163,9	163,9	163,9	163,9	163,9
25	-	-	-	-	-	-	-	-	-	-	-	-	-	117,8	129,6	141,4	153,2	164,9	176,7	188,5	200,3	212,1	223,8	235,6	256,1
28	-	-	-	-	-	-	-	-	-	-	-	-	-	-	145,1	158,3	171,5	184,7	197,9	211,1	224,3	237,5	250,7	263,9	321,3
30	-	-	-	-	-	-	-	-	-	-	-	-	-	-	-	-	178,1	190,9	203,6	216,3	229,0	241,7	254,5	267,3	368,8
32	-	-	-	-	-	-	-	-	-	-	-	-	-	-	-	-	190,0	203,6	217,1	230,7	244,3	257,9	271,4	285,0	419,6

Product commercial data

Product Code	Volume [ml]	Quantity [pcs]			Weight [kg]			Bar Codes
		Box	Outer	Pallet	Box	Outer	Pallet	
R-CFS+RV200-4 ¹⁾	300	1	8	96	2.4	19.3	261.3	5906675205830
R-CFS+RV200-600-8 ¹⁾	600	1	1	36	10.0	10.0	390.0	5906675119045

1) ETA-12/0319

RM50 with Threaded Rods for Concrete (CFS+)

Universal polyester (styrene free) resin - European Approval for 15 substrates
- Cartridge Free System (CFS+)



Approvals and Reports

- ETA-12/0394



Installation movie

Product overview

Features and benefits

- The most contemporary general use bonded anchor
- Quick, secure and simple installation
- Unique soft foil pack for less waste
- Effortless extrusion due to patented self-opening system with manual or pneumatic dispenser guns
- Product with wide spectrum of use in the medium load capacity area
- Ideal for applications without the possibility of mechanical anchorage
- Suitable for multiple use. Partly used product can be reused after fitting spare nozzle

Applications

- Balustrading
- Handrails
- Canopies
- Curtain walling
- Consoles
- Staircases
- Gates
- High racking
- Sanitary appliances
- Steel constructions
- Railings
- Ladders
- Cable trays

Base materials

Approved for use in:

- Non-cracked concrete C20/25-C50/60

Also suitable for use in:

- Natural Stone

Installation guide

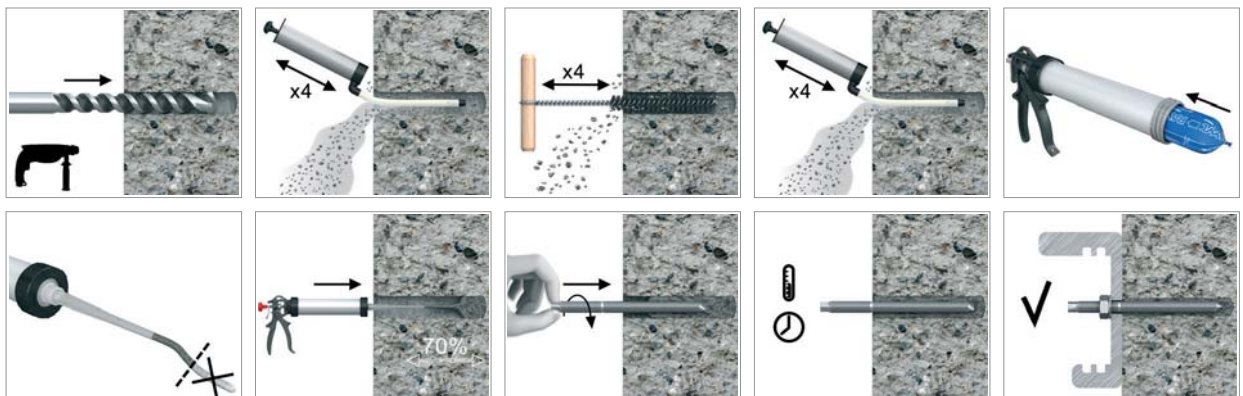

Installation guide (cont.)

1. Drill hole to the required diameter and depth for stud size being used.
2. Clean the hole thoroughly with brush and hand pump at least four times before installation.
3. Insert foil into gun and attach nozzle.
4. Dispense to waste until even colour is obtained.
5. Insert the mixer nozzle to the bottom of the drill hole and inject resin, slowly withdrawing the nozzle as the hole is filled to 70% of its depth.
6. Immediately insert the stud, slowly and with slight twisting motion. Remove any excess resin around the hole before it sets and leave it undisturbed until the curing time elapses.
7. Attach fixture and tighten the nut to the required torque.

Product information

Product Code	Resin	Description / Resin Type	Volume
			[ml]
R-CFS+RM50-4	RM50	Styrene Free Polyester Resin	300
R-CFS+RM50S-4	RM50-S	High Temperature (Summer) / Slow Cure Styrene Free Polyester Resin	
R-CFS+RM50W-4	RM50-W	Low Temperature (Winter) / Rapid Cure Styrene Free Polyester Resin	
R-CFS+RM50-600-8	RM50	Styrene Free Polyester Resin	600

R-STUDS

Size	Product Code			Anchor		Fixture		
	Steel class 5.8	Steel class 8.8	Steel grade A4	Diameter	Length	Hole diameter	Max. thickness t_{fix} for:	
				d	L	d_f	$h_{nom, min}$	$h_{nom, max}$
				[mm]	[mm]	[mm]	[mm]	[mm]
M8	R-STUDS-08110	R-STUDS-08110-88	R-STUDS-08110-A4	8	110	9	40	-
	R-STUDS-08160	-	R-STUDS-08160-A4	8	160	9	90	50
M10	R-STUDS-10130	R-STUDS-10130-88	R-STUDS-10130-A4	10	130	12	48	-
	R-STUDS-10170	-	R-STUDS-10170-A4	10	170	12	88	38
	R-STUDS-10190	-	R-STUDS-10190-A4	10	190	12	108	58
M12	R-STUDS-12160	R-STUDS-12160-88	R-STUDS-12160-A4	12	160	14	65	-
	R-STUDS-12190	-	R-STUDS-12190-A4	12	190	14	95	30
	R-STUDS-12220	-	R-STUDS-12220-A4	12	220	14	125	60
	R-STUDS-12260	-	R-STUDS-12260-A4	12	260	14	165	100
M16	R-STUDS-12300	-	R-STUDS-12300-A4	12	300	14	205	140
	R-STUDS-16190	R-STUDS-16190-88	R-STUDS-16190-A4	16	190	18	71	-
	R-STUDS-16220	R-STUDS-16220-88	R-STUDS-16220-A4	16	220	18	101	11
	R-STUDS-16260	-	R-STUDS-16260-A4	16	260	18	141	51
	R-STUDS-16300	-	R-STUDS-16300-A4	16	300	18	181	91
M20	R-STUDS-16380	-	R-STUDS-16380-A4	16	380	18	261	171
	R-STUDS-20260	R-STUDS-20260-88	R-STUDS-20260-A4	20	260	22	117	-
	R-STUDS-20300	-	R-STUDS-20300-A4	20	300	22	157	37
M24	R-STUDS-20350	-	R-STUDS-20350-A4	20	350	22	207	87
	R-STUDS-24300	R-STUDS-24300-88	R-STUDS-24300-A4	24	300	26	132	-
M30	R-STUDS-30380	R-STUDS-30380-88	R-STUDS-30380-A4	30	380	32	181	-

Installation data

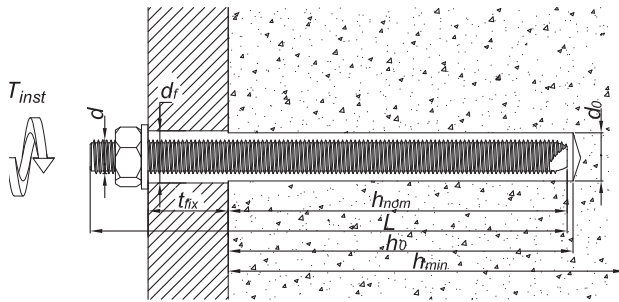

R-STUDS

Size	M8	M10	M12	M16	M20	M24	M30		
Thread diameter	d	[mm]	8	10	12	16	20	24	30
Hole diameter in substrate	d ₀	[mm]	10	12	14	18	24	28	35
Hole diameter in fixture	d _f	[mm]	9	12	14	18	24	28	35
Min. hole depth in substrate	h ₀	[mm]	h _{nom} + 5	h _{nom} + 5	h _{nom} + 5	h _{nom} + 5	h _{nom} + 5	h _{nom} + 5	h _{nom} + 5
Min. substrate thickness	h _{min}	[mm]	h _{nom} + 2d ₀ ≥ 100	h _{nom} + 2d ₀ ≥ 100	h _{nom} + 2d ₀ ≥ 100	h _{nom} + 2d ₀ ≥ 100	h _{nom} + 2d ₀ ≥ 100	h _{nom} + 2d ₀ ≥ 100	h _{nom} + 2d ₀ ≥ 100
Installation torque	T _{inst}	[Nm]	10	20	40	80	120	180	300
Min. spacing	s _{min}	[mm]	0.5 * h _{nom} ≥ 40	0.5 * h _{nom} ≥ 40	0.5 * h _{nom} ≥ 40	0.5 * h _{nom} ≥ 40	0.5 * h _{nom} ≥ 40	0.5 * h _{nom} ≥ 40	0.5 * h _{nom} ≥ 40
Min. edge distance	c _{min}	[mm]	0.5 * h _{nom} ≥ 40	0.5 * h _{nom} ≥ 40	0.5 * h _{nom} ≥ 40	0.5 * h _{nom} ≥ 40	0.5 * h _{nom} ≥ 40	0.5 * h _{nom} ≥ 40	0.5 * h _{nom} ≥ 40
MINIMUM EMBEDMENT DEPTH									
Installation depth	h _{nom, min}	[mm]	60	70	80	100	120	140	165
MAXIMUM EMBEDMENT DEPTH									
Installation depth	h _{nom, max}	[mm]	100	120	145	190	240	290	360

Minimum working and curing time

Resin temperature [°C]	Concrete temperature [°C]	Working time [min]			Curing time* [min]		
		RM50-S	RM50	RM50-W	RM50-S	RM50	RM50-W
5	-20	-	-	45	-	-	24h
5	-15	-	-	30	-	-	18h
5	-10	-	-	20	-	-	8h
5	-5	3h	70	11	24h	8h	5h
5	0	2h	45	7	18h	4h	2h
5	5	1h	25	5	12h	2h	1h
10	10	45	15	2	8h	90	45
15	15	25	9	1,5	6h	60	30
20	20	15	5	1	4h	45	15
25	30	7	2	-	1.5h	30	-
25	35	6	-	-	1h	-	-
25	40	5	-	-	45	-	-

*For wet concrete the curing time must be doubled

Mechanical properties

Size			M8	M10	M12	M16	M20	M24	M30
R-STUDS METRIC THREADED RODS - steel class 5.8									
Nominal ultimate tensile strength - tension	f_{uk}	[N/mm ²]	500	500	500	500	500	500	500
Nominal yield strength - tension	f_{yk}	[N/mm ²]	400	400	400	400	400	400	400
Cross sectional area - tension	A_s	[mm ²]	36.6	58	84.3	157	245	352.8	559.8
Elastic section modulus	W_{el}	[mm ³]	31.2	62.3	109.2	277.5	541	935	1868
Characteristic bending resistance	$M_{Rk,s}^0$	[Nm]	19	37	65	166	324	561	1124
Design bending resistance	M	[Nm]	15	30	52	133	259	449	899
Allowable bending resistance	M_{rec}	[Nm]	11	21	37	95	185	321	642
R-STUDS METRIC THREADED RODS - steel class 8.8									
Nominal ultimate tensile strength - tension	f_{uk}	[N/mm ²]	800	800	800	800	800	800	800
Nominal yield strength - tension	f_{yk}	[N/mm ²]	640	640	640	640	640	640	640
Cross sectional area - tension	A_s	[mm ²]	36.6	58	84.3	157	245	352.8	559.8
Elastic section modulus	W_{el}	[mm ³]	31.2	62.3	109.2	277.5	541	935	1868
Characteristic bending resistance	$M_{Rk,s}^0$	[Nm]	30	60	105	266	519	898	1799
Design bending resistance	M	[Nm]	24	48	84	213	416	718	1439
Allowable bending resistance	M_{rec}	[Nm]	17	34	60	152	297	513	1028
R-STUDS METRIC THREADED RODS - A4									
Nominal ultimate tensile strength - tension	f_{uk}	[N/mm ²]	700	700	700	700	700	700	700
Nominal yield strength - tension	f_{yk}	[N/mm ²]	350	350	350	350	350	350	350
Cross sectional area - tension	A_s	[mm ²]	36.6	58	84.3	157	245	352.8	559.8
Elastic section modulus	W_{el}	[mm ³]	31.2	62.3	109.2	277.5	541	935	1868
Characteristic bending resistance	$M_{Rk,s}^0$	[Nm]	26	52	92	233	454	786	1574
Design bending resistance	M	[Nm]	17	34	59	149	291	504	1009
Allowable bending resistance	M_{rec}	[Nm]	12	24	42	107	208	360	721

Basic performance data

R-STUDS

Performance data for single anchor without influence of edge distance and spacing

Size			M8	M10	M12	M16	M20	M24	M30
Substrate	Non-cracked concrete								
TENSION LOAD N_{Rk}									
R-STUDS METRIC THREADED RODS - STEEL CLASS 5.8									
Minimum embedment depth	[kN]	14.3	20.9	27.1	40.2	60.3	68.6	85.5	
Maximum embedment depth	[kN]	18.0	29.0	42.0	76.4	120.6	142.1	186.6	
R-STUDS METRIC THREADED RODS - STEEL CLASS 8.8									
Minimum embedment depth	[kN]	14.3	20.9	27.1	40.2	60.3	68.6	85.5	
Maximum embedment depth	[kN]	23.9	35.8	49.2	76.4	120.6	142.1	186.6	
R-STUDS METRIC THREADED RODS - A4									
Minimum embedment depth	[kN]	14.3	20.9	27.1	40.2	60.3	68.6	85.5	
Maximum embedment depth	[kN]	23.9	35.8	49.2	76.4	120.6	142.1	186.6	
SHEAR LOAD V_{Rk}									
R-STUDS METRIC THREADED RODS - STEEL CLASS 5.8									
Minimum embedment depth	[kN]	9.00	14.0	21.0	39.0	61.0	88.0	140.0	
Maximum embedment depth	[kN]	9.00	14.0	21.0	39.0	61.0	88.0	140.0	
R-STUDS METRIC THREADED RODS - STEEL CLASS 8.8									
Minimum embedment depth	[kN]	15.0	23.0	34.0	63.0	98.0	137.2	171.1	
Maximum embedment depth	[kN]	15.0	23.0	34.0	63.0	98.0	141.0	224.0	
R-STUDS METRIC THREADED RODS - A4									
Minimum embedment depth	[kN]	13.0	20.0	29.0	86.0	86.0	124.0	171.1	
Maximum embedment depth	[kN]	13.0	20.0	29.0	86.0	86.0	124.0	196.0	

Basic performance data (cont.)

Size		M8	M10	M12	M16	M20	M24	M30
Substrate		Non-cracked concrete						
DESIGN LOAD								
TENSION LOAD N_{Rd}								
R-STUDS METRIC THREADED RODS - STEEL CLASS 5.8								
Minimum embedment depth	[kN]	6.82	11.6	15.1	22.3	33.5	38.1	47.5
Maximum embedment depth	[kN]	11.4	19.3	27.3	42.5	67.0	79.0	103.7
R-STUDS METRIC THREADED RODS - STEEL CLASS 8.8								
Minimum embedment depth	[kN]	6.82	11.6	15.1	22.3	33.5	38.1	47.5
Maximum embedment depth	[kN]	11.4	19.9	27.3	42.5	67.0	79.0	103.7
R-STUDS METRIC THREADED RODS - A4								
Minimum embedment depth	[kN]	6.82	11.6	15.1	22.3	33.5	38.1	47.5
Maximum embedment depth	[kN]	11.4	19.9	27.3	42.5	67.0	79.0	103.7
SHEAR LOAD V_{Rd}								
R-STUDS METRIC THREADED RODS - STEEL CLASS 5.8								
Minimum embedment depth	[kN]	7.20	11.2	16.8	31.2	48.8	70.4	112.0
Maximum embedment depth	[kN]	7.20	11.2	16.8	31.2	48.8	70.4	112.0
R-STUDS METRIC THREADED RODS - STEEL CLASS 8.8								
Minimum embedment depth	[kN]	12.0	18.4	27.2	50.4	78.4	91.5	114.0
Maximum embedment depth	[kN]	12.0	18.4	27.2	50.4	78.4	112.8	179.2
R-STUDS METRIC THREADED RODS - A4								
Minimum embedment depth	[kN]	8.33	12.8	18.6	55.1	55.1	79.5	114.0
Maximum embedment depth	[kN]	8.33	12.8	18.6	55.1	55.1	79.5	125.6
RECOMMENDED LOAD								
TENSION LOAD N_{rec}								
R-STUDS METRIC THREADED RODS - STEEL CLASS 5.8								
Minimum embedment depth	[kN]	4.87	8.29	10.8	16.0	23.9	27.2	33.9
Maximum embedment depth	[kN]	8.12	13.8	19.5	30.3	47.9	56.4	74.1
R-STUDS METRIC THREADED RODS - STEEL CLASS 8.8								
Minimum embedment depth	[kN]	4.87	8.29	10.8	16.0	23.9	27.2	33.9
Maximum embedment depth	[kN]	8.12	14.2	19.5	30.3	47.9	56.4	74.1
R-STUDS METRIC THREADED RODS - A4								
Minimum embedment depth	[kN]	4.87	8.29	10.8	16.0	23.9	27.2	33.9
Maximum embedment depth	[kN]	8.12	14.2	19.5	30.3	47.9	56.4	74.1
SHEAR LOAD V_{rec}								
R-STUDS METRIC THREADED RODS - STEEL CLASS 5.8								
Minimum embedment depth	[kN]	5.14	8.00	12.0	22.3	34.9	50.3	80.0
Maximum embedment depth	[kN]	5.14	8.00	12.0	22.3	34.9	50.3	80.0
R-STUDS METRIC THREADED RODS - STEEL CLASS 8.8								
Minimum embedment depth	[kN]	8.57	13.1	19.4	36.0	56.0	65.4	81.5
Maximum embedment depth	[kN]	8.57	13.1	19.4	36.0	56.0	80.6	128.0
R-STUDS METRIC THREADED RODS - A4								
Minimum embedment depth	[kN]	5.95	9.16	13.3	39.4	39.4	56.8	81.5
Maximum embedment depth	[kN]	5.95	9.16	13.3	39.4	39.4	56.8	89.7

Product commercial data

Product Code	Volume [ml]	Quantity [pcs]			Weight [kg]			Bar Codes
		Box	Outer	Pallet	Box	Outer	Pallet	
CFS+RM50-4 ¹⁾	300							
CFS+RM50S-4 ¹⁾	300							
CFS+RM50W-4 ¹⁾	300							
R-CFS+RM50-600-8 ¹⁾	600	1	1	36	8.4	8.4	333.6	5906675078823

RM50 with Threaded Rods for Masonry (CFS+)

Universal polyester (styrene free) resin - European Approval for 15 substrates
- Cartridge Free System (CFS+)



Approvals and Reports

- ETA-12/0528



Installation movie

Product overview

Features and benefits

- The most contemporary general use bonded anchor for masonry
- Approved for 15 substrates
- Quick, secure and simple installation
- Unique soft foil pack for less waste
- Effortless extrusion due to patented self-opening system with manual or battery dispenser guns
- Product with wide spectrum of use in the medium load capacity area
- Ideal for applications without the possibility of mechanical anchorage
- Suitable for multiple use. Partly used product can be reused after fitting spare nozzle

Applications

- Balustrading
- Handrails
- Canopies
- Curtain walling
- Bathroom fittings
- Cable trays
- Barriers
- Cladding restraint
- Fencing & gates
- Pipework

Base materials

Approved for use in:

- Solid Brick
- Solid Sand-lime Brick
- Hollow Sand-lime Brick
- Hollow Brick
- Hollow Lightweight Concrete Block
- Aerated Concrete Block

Installation guide



Installation guide (cont.)

1. Drill hole to the required diameter and depth for stud size being used.
2. Insert mesh sleeve into the hole.
3. Insert foil into gun and attach nozzle.
4. Dispense to waste until even colour is obtained. Insert the mixer nozzle to the bottom of the drill hole and inject resin, slowly withdrawing the nozzle as the hole is filled to 70% of its depth.
5. Immediately insert the stud, slowly and with slight twisting motion. Remove any excess resin around the hole before it sets and leave it undisturbed until the curing time elapses.
6. Attach fixture and tighten the nut to the required installation torque

Product information

Product Code	Resin	Description / Resin Type	Volume
			[ml]
R-CFS+RM50-4	RM50	Styrene Free Polyester Resin	300
R-CFS+RM50-600-8	RM50	Styrene Free Polyester Resin	600

R-STUDS

Size	Product Code			Anchor		Fixture		
	Steel class 5.8	Steel class 8.8	Steel grade A4	Diameter	Length	Hole diameter	Max. thickness	
				d	L	d _r	t _{fix} for h _{nom,min}	t _{fix} for h _{nom,max}
				[mm]	[mm]	[mm]	[mm]	[mm]
M8	R-STUDS-08110	R-STUDS-08110-88	R-STUDS-08110-A4	8	110	9	40	-
	R-STUDS-08160	-	R-STUDS-08160-A4*	8	160	9	90	50
M10	R-STUDS-10130	R-STUDS-10130-88	R-STUDS-10130-A4	10	130	12	48	-
	R-STUDS-10170	-	R-STUDS-10170-A4*	10	170	12	88	38
	R-STUDS-10190	-	R-STUDS-10190-A4*	10	190	12	108	58
M12	R-STUDS-12160	R-STUDS-12160-88	R-STUDS-12160-A4	12	160	14	65	-
	R-STUDS-12190	-	R-STUDS-12190-A4*	12	190	14	95	30
	R-STUDS-12220	-	R-STUDS-12220-A4*	12	220	14	125	60
	R-STUDS-12260	-	R-STUDS-12260-A4*	12	260	14	165	100
	R-STUDS-12300	-	R-STUDS-12300-A4*	12	300	14	205	140
M16	R-STUDS-16190	R-STUDS-16190-88	R-STUDS-16190-A4	16	190	18	71	-
	R-STUDS-16220	R-STUDS-16220-88	R-STUDS-16220-A4*	16	220	18	101	11
	R-STUDS-16260	-	R-STUDS-16260-A4*	16	260	18	141	51
	R-STUDS-16300	-	R-STUDS-16300-A4*	16	300	18	181	91
	R-STUDS-16380	-	R-STUDS-16380-A4*	16	380	18	261	171

* Make to order

Product information (cont.)

R-PLS Plastic Mesh Sleeves and SP-CE Mesh Sleeves

Product Code	Size		Quantity [pcs]		Weight [kg]		Bar Code
	Sleeve [mm]	Stud	Outer	Pallet	Box	Outer	
R-PLS-12050-10	12x50	M8	700	8400	0.06	4.2	5906675377520
R-PLS-16085-10	16x85	M10-M12	500	6000	0.05	2.5	5906675347547
R-PLS-16130-10	16x130	M10-M12	400	4800	0.10	4.0	5906675347554
R-PLS-20085-10	20x85	M16	400	4800	0.8	0.8	5906675291864
SP-CE-R08	12X1000	M6-M8	10	5430	-	0.64	5906675266138
SP-CE-R10	14x1000	M8-M10	10	1500	-	0.56	5906675610122
SP-CE-R12	16x1000	M12	10	1300	-	0.66	5906675610320
SP-CE-R16	20x1000	M16	10	384	-	1.29	5906675610528
SP-CE-R20	24x1000	M20	5	280	-	0.57	5906675610726

Installation data

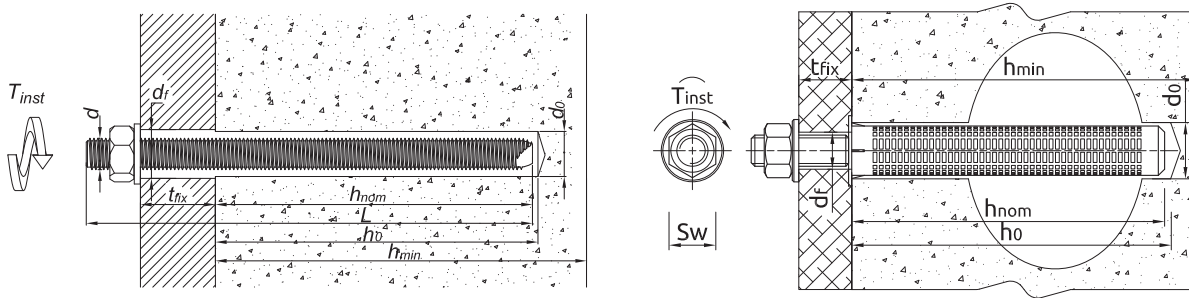

SOLID SUBSTRATES

Size	M8	M10	M12	M16	M8	M10	M12	M16		
Substrate	Ceramic solid substrates				Aerated concrete					
Thread diameter	d	[mm]	8	10	12	16	8	10	12	16
Hole diameter in substrate	d ₀	[mm]	10	12	14	18	10	12	14	18
Installation torque	T _{inst}	[Nm]	5	8	10	15	3	4	6	10
Min. hole depth in substrate	h ₀	[mm]	h _{nom} + 5							
Installation depth	h _{nom,min}	[mm]	80	85	95	105	80	85	95	105
Min. spacing	s _{min}	[mm]	50	50	50	54	50	50	50	54
Min. edge distance	c _{min}	[mm]	50	50	50	54	50	50	50	54

HOLLOW SUBSTRATES

Size	M10	M10	M12	M16						
Substrate	Hollow substrates									
Thread diameter	d	[mm]	8	8	10	10	12	12	16	
Plastic mesh sleeve size	d _{xl}	[mm]	12x50	12x80	16x85	16x130	16x85	16x130	20x85	
Hole diameter in substrate	d ₀	[mm]	12	12	16	16	16	16	20	
Installation torque	T _{inst}	[Nm]	3	3	4	4	6	6	10	
Min. hole depth in substrate	h ₀	[mm]	h _{nom} + 5							
Installation depth	h _{nom,std}	[mm]	50	-	85	-	85	-	85	
	h _{nom,max}	[mm]	-	80	-	125	-	125	-	
Min. spacing	s _{min}	[mm]	100	100	100	100	100	100	120	
Min. edge distance	c _{min}	[mm]	100	100	100	100	100	100	120	

Installation data (cont.)

Minimum working and curing time

Resin temperature [°C]	Concrete temperature [°C]	Working time [min]			Curing time* [min]		
		RM50-S	RM50	RM50-W	RM50-S	RM50	RM50-W
5	-20	-	-	45	-	-	24 h
5	-15	-	-	30	-	-	18 h
5	-10	-	-	20	-	-	8 h
5	-5	3 h	70	11	24 h	8 h	5 h
5	0	2 h	45	7	18 h	4 h	2 h
5	5	1 h	25	5	12 h	2 h	1 h
10	10	45	15	2	8 h	1.5 h	45
15	15	25	9	1,5	6 h	1 h	30
20	20	15	5	1	4 h	45	15
25	30	7	2	-	1.5 h	30	-
25	35	6	-	-	1 h	-	-
25	40	5	-	-	45	-	-

*For wet concrete the curing time must be doubled

Mechanical properties

R-STUDS

Size			M8	M10	M12	M16
R-STUDS METRIC THREADED RODS - steel class 5.8						
Nominal ultimate tensile strength - tension	f_{uk}	[N/mm ²]	500	500	500	500
Nominal yield strength - tension	f_{yk}	[N/mm ²]	400	400	400	400
Cross sectional area - tension	A_s	[mm ²]	36.6	58	84.3	157
Elastic section modulus	W_{el}	[mm ³]	31.2	62.3	109.2	277.5
Characteristic bending resistance	$M_{Rk,S}^0$	[Nm]	19	37	65	166
Design bending resistance	M	[Nm]	15	30	52	133
Allowable bending resistance	M_{rec}	[Nm]	11	21	37	95
R-STUDS METRIC THREADED RODS - steel class 8.8						
Nominal ultimate tensile strength - tension	f_{uk}	[N/mm ²]	800	800	800	800
Nominal yield strength - tension	f_{yk}	[N/mm ²]	640	640	640	640
Cross sectional area - tension	A_s	[mm ²]	36.6	58	84.3	157
Elastic section modulus	W_{el}	[mm ³]	31.2	62.3	109.2	277.5
Characteristic bending resistance	$M_{Rk,S}^0$	[Nm]	30	60	105	266
Design bending resistance	M	[Nm]	24	48	84	213
Allowable bending resistance	M_{rec}	[Nm]	17	34	60	152
R-STUDS METRIC THREADED RODS - A4						
Nominal ultimate tensile strength - tension	f_{uk}	[N/mm ²]	700	700	700	700
Nominal yield strength - tension	f_{yk}	[N/mm ²]	350	350	350	350
Cross sectional area - tension	A_s	[mm ²]	36.6	58	84.3	157
Elastic section modulus	W_{el}	[mm ³]	31.2	62.3	109.2	277.5
Characteristic bending resistance	$M_{Rk,S}^0$	[Nm]	26	52	92	233
Design bending resistance	M	[Nm]	17	34	59	149
Allowable bending resistance	M_{rec}	[Nm]	12	24	42	107

Basic performance data

SOLID SUBSTRATES

Performance data for single anchor without influence of edge distance and spacing

Size			M8	M10	M12	M16
Substrate	Solid substrates					
CHARACTERISTIC LOAD*						
TENSION LOADS N_{Rk}						
Solid clay brick min 20 MPa (eg Mz20/2.0)	[kN]		6.00	7.00	7.00	7.00
Autoclaved aerated concrete block min 6.0 MPa (AAC7)	[kN]		1.50	2.00	2.50	3.00
Solid silicate brick min 20 MPa (eg KS NF 20/2.0)	[kN]		5.00	5.00	5.00	5.00

Basic performance data (cont.)

SOLID SUBSTRATES

Performance data for single anchor without influence of edge distance and spacing

Size		M8	M10	M12	M16
SHEAR LOADS V_{Rk}					
Solid clay brick min 20 MPa (eg Mz20/2.0)	[kN]	3.50	5.00	7.00	7.00
Autoclaved aerated concrete block min 6.0 MPa (AAC7)	[kN]	1.50	2.00	2.50	2.50
Solid silicate brick min 20 MPa (eg KS NF 20/2.0)	[kN]	3.50	5.00	5.00	5.00
DESIGN LOAD					
TENSION LOAD N_{Rd}					
Solid clay brick min 20 MPa (eg Mz20/2.0)	[kN]	2.40	2.80	2.80	2.80
Autoclaved aerated concrete block min 6.0 MPa (AAC7)	[kN]	0.75	1.00	1.25	1.50
Solid silicate brick min 20 MPa (eg KS NF 20/2.0)	[kN]	2.00	2.00	2.00	2.00
SHEAR LOAD V_{Rd}					
Solid clay brick min 20 MPa (eg Mz20/2.0)	[kN]	1.40	2.00	2.80	2.80
Autoclaved aerated concrete block min 6.0 MPa (AAC7)	[kN]	0.75	1.00	1.25	1.25
Solid silicate brick min 20 MPa (eg KS NF 20/2.0)	[kN]	1.40	2.00	2.00	2.00
RECOMMENDED LOAD**					
TENSION LOAD N_{rec}					
Solid clay brick min 20 MPa (eg Mz20/2.0)	[kN]	1.71	2.00	2.00	2.00
Autoclaved aerated concrete block min 6.0 MPa (AAC7)	[kN]	0.54	0.71	0.89	1.07
Solid silicate brick min 20 MPa (eg KS NF 20/2.0)	[kN]	1.43	1.43	1.43	1.43
SHEAR LOAD V_{rec}					
Solid clay brick min 20 MPa (eg Mz20/2.0)	[kN]	1.00	1.43	2.00	2.00
Autoclaved aerated concrete block min 6.0 MPa (AAC7)	[kN]	0.54	0.71	0.89	0.89
Solid silicate brick min 20 MPa (eg KS NF 20/2.0)	[kN]	1.00	1.43	1.43	1.43

*According to ETAG 029, **Partial safety factor 1.4

HOLLOW SUBSTRATES

Performance data for single anchor without influence of edge distance and spacing

Size		M8	M10	M12	M16			
Substrate		Hollow substrates						
Plastic mesh sleeve (dxl)	[mm]	12x50	12x80	16x85	15x130	16x85	16x130	20x85
CHARACTERISTIC LOAD								
TENSION AND SHEAR LOADS F_{Rk}								
Silicate hollow block min 12 MPa (eg KS Ratio Block 8 DF)	[kN]	2.50	2.50	2.50	3.50	3.00	3.00	3.00
Perforated ceramic blocks min 12 MPa (eg Proton Hlz 12/0.9 DF)	[kN]	2.00	2.50	2.50	2.50	2.50	2.50	2.50
Perforated ceramic blocks min 15 MPa (eg Wienerberger Porotherm)	[kN]	1.50	2.00	2.00	2.50	2.50	2.50	2.50
Perforated ceramic blocks min 10 MPa (eg Leiter Thermopor)	[kN]	1.50	2.00	2.00	2.50	2.50	2.50	2.50
Perforated ceramic blocks min 15 MPa (eg MEGA MAX)	[kN]	2.00	2.50	2.50	2.50	2.50	2.50	2.50
Perforated ceramic blocks min 6.0 MPa (eg LS Tableau Mono Rect)	[kN]	0.90	0.90	1.50	2.00	2.00	2.00	1.20
Perforated ceramic blocks min 6.0 MPa (eg LS Tableau Rect)	[kN]	0.90	1.20	1.50	1.50	1.50	2.00	1.50
Perforated ceramic blocks min 6.0 MPa (eg LS Monomur)	[kN]	0.90	0.90	1.20	1.50	1.50	1.50	1.50
Perforated ceramic blocks min 6 MPa (eg SM BGV Thermo)	[kN]	0.90	0.90	1.50	1.50	1.50	1.50	1.50
Perforated ceramic blocks min 6.0 MPa (eg SM BGV Thermo Plus)	[kN]	0.90	1.20	0.90	0.90	1.20	1.50	1.20
Lightweight concrete hollow block min 2.0 MPa	[kN]	1.20	1.50	2.50	2.00	2.50	2.50	2.50

Basic performance data (cont.)

HOLLOW SUBSTRATES

Performance data for single anchor without influence of edge distance and spacing

Size		M8	M10	M12	M16			
DESIGN LOAD								
TENSION AND SHEAR LOADS F_{Rd}								
Silicate hollow block min 12 MPa (eg KS Ratio Block 8 DF)	[kN]	1.00	1.00	1.40	1.00	1.20	1.20	1.20
Perforated ceramic blocks min 12 MPa (eg Proton Hz 12/0.9 DF)	[kN]	0.88	1.00	1.40	1.20	1.40	1.60	1.60
Perforated ceramic blocks min 15 MPa (eg Wienerberger Porotherm)	[kN]	0.60	0.80	1.00	1.00	1.40	1.40	1.00
Perforated ceramic blocks min 10 MPa (eg Leiter Thermopor)	[kN]	0.60	0.80	1.00	0.80	1.00	1.40	1.20
Perforated ceramic blocks min 15 MPa (eg MEGA MAX)	[kN]	0.80	1.00	1.40	1.40	1.60	1.60	1.60
Perforated ceramic blocks min 6.0 MPa (eg LS Tableau Mono Rect)	[kN]	0.36	0.36	0.80	0.80	0.80	0.80	0.60
Perforated ceramic blocks min 6.0 MPa (eg LS Tableau Rect)	[kN]	0.48	0.48	0.60	0.60	0.80	0.80	0.60
Perforated ceramic blocks min 6.0 MPa (eg LS Monomur)	[kN]	0.36	0.36	0.60	0.60	0.60	0.60	0.60
Perforated ceramic blocks min 6 MPa (eg SM BGV Thermo)	[kN]	0.36	0.36	0.60	0.60	0.60	0.60	0.60
Perforated ceramic blocks min 6.0 MPa (eg SM BGV Thermo Plus)	[kN]	0.48	0.48	0.48	0.48	0.48	0.60	0.48
Lightweight concrete hollow block min 2.0MPa	[kN]	0.48	0.60	1.00	1.00	1.00	1.40	1.40
RECOMMENDED LOAD								
TENSION AND SHEAR LOADS F_{rec}								
Silicate hollow block min 12 MPa (eg KS Ratio Block 8 DF)	[kN]	0.71	0.71	1.00	0.71	0.86	0.86	0.86
Perforated ceramic blocks min 12 MPa (eg Proton Hz 12/0.9 DF)	[kN]	0.63	0.71	1.00	0.86	1.00	1.14	1.14
Perforated ceramic blocks min 15 MPa (eg Wienerberger Porotherm)	[kN]	0.43	0.57	0.71	0.71	1.00	1.00	0.71
Perforated ceramic blocks min 10 MPa (eg Leiter Thermopor)	[kN]	0.43	0.57	0.71	0.57	0.71	1.00	0.86
Perforated ceramic blocks min 15 MPa (eg MEGA MAX)	[kN]	0.57	0.71	1.00	1.00	1.14	1.14	1.14
Perforated ceramic blocks min 6.0 MPa (eg LS Tableau Mono Rect)	[kN]	0.26	0.26	0.57	0.57	0.57	0.57	0.43
Perforated ceramic blocks min 6.0 MPa (eg LS Tableau Rect)	[kN]	0.34	0.34	0.43	0.43	0.57	0.57	0.43
Perforated ceramic blocks min 6.0 MPa (eg LS Monomur)	[kN]	0.26	0.26	0.43	0.43	0.43	0.43	0.43
Perforated ceramic blocks min 6 MPa (eg SM BGV Thermo)	[kN]	0.26	0.26	0.43	0.43	0.43	0.43	0.43
Perforated ceramic blocks min 6.0 MPa (eg SM BGV Thermo Plus)	[kN]	0.34	0.34	0.34	0.34	0.34	0.43	0.34
Lightweight concrete hollow block min 2.0 MPa	[kN]	0.34	0.43	0.71	0.71	0.71	1.00	1.00

*According to ETAG 029, **Partial safety factor 1.4

Product commercial data

Product Code	Volume [m ³]	Quantity [pcs]			Weight [kg]			Bar Code	Shelf Life [month]
		Box	Outer	Pallet	Box	Outer	Pallet		
R-CFS+RM50-4	300	1	3	108	2.44	7.32	263.52	5906675205892	18
R-CFS+RM50-600-8	600	1	1	36	8.30	8.30	298.8	5906675078823	18

RP30 (CFS+) with Threaded Rods for Concrete

Economy polyester resin approved for use in non-cracked concrete
- Cartridge Free System (CFS+)



Approvals and Reports

- ETA-11/0141

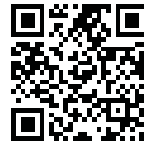

Installation movie

Product overview

Features and benefits

- Effortless extrusion due to patented self-opening system with manual or battery dispenser guns
- Medium load capacity in non-cracked concrete
- Wide range of steel studs with different lengths and diameters
- Small edge and space distances

Applications

- Cable trays
- Handrails
- Fencing & gates manufacturing and installation
- Pipework installation
- Consoles
- Staircases
- Gates
- High racking
- Canopies
- Sanitary appliances
- Railings
- Ladders
- Cable trays

Base materials

Approved for use in:

- Non-cracked concrete C20/25-C50/60

Installation guide

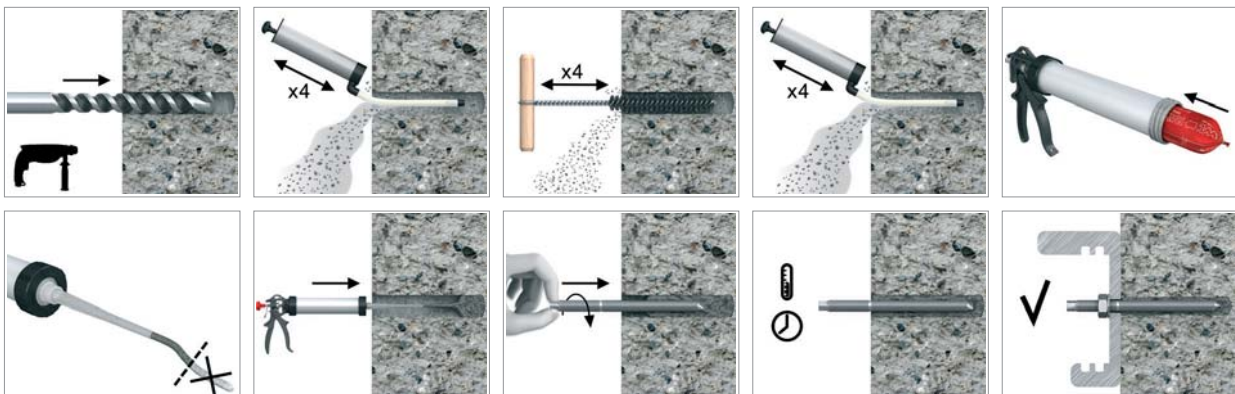

Installation guide (cont.)

1. Drill hole to the required diameter and depth for stud size being used.
2. Clean the hole thoroughly with brush and hand pump at least four times before installation.
3. Insert foil into gun and attach nozzle.
4. Dispense to waste until even colour is obtained.
5. Insert the mixer nozzle to the bottom of the drill hole and inject resin, slowly withdrawing the nozzle as the hole is filled to 70% of its depth.
6. Immediately insert the stud, slowly and with slight twisting motion. Remove any excess resin around the hole before it sets and leave it undisturbed until the curing time elapses.
7. Attach fixture and tighten the nut to the required torque.

Product information

Product Code	Resin	Description / Resin Type	Volume
			[ml]
R-CFS+RP30-4	RP30	Polyester Resin	300
R-CFS+RP30-600-8	RP30	Polyester Resin	600

R-STUDS

Size	Product Code			Anchor		Fixture		
	Steel class 5.8	Steel class 8.8	Steel grade A4	Diameter	Length	Hole diameter	Max. thickness	
				d	L	d _f	t _{fix} for h _{nom,min}	t _{fix} for h _{nom,max}
				[mm]	[mm]	[mm]	[mm]	[mm]
M8	R-STUDS-08110	R-STUDS-08110-88	R-STUDS-08110-A4	8	110	9	40	-
	R-STUDS-08160	-	R-STUDS-08160-A4*	8	160	9	90	50
M10	R-STUDS-10130	R-STUDS-10130-88	R-STUDS-10130-A4	10	130	12	48	-
	R-STUDS-10170	-	R-STUDS-10170-A4*	10	170	12	88	38
	R-STUDS-10190	-	R-STUDS-10190-A4*	10	190	12	108	58
M12	R-STUDS-12160	R-STUDS-12160-88	R-STUDS-12160-A4	12	160	14	65	-
	R-STUDS-12190	-	R-STUDS-12190-A4*	12	190	14	95	30
	R-STUDS-12220	-	R-STUDS-12220-A4*	12	220	14	125	60
	R-STUDS-12260	-	R-STUDS-12260-A4*	12	260	14	165	100
	R-STUDS-12300	-	R-STUDS-12300-A4*	12	300	14	205	140
M16	R-STUDS-16190	R-STUDS-16190-88	R-STUDS-16190-A4	16	190	18	71	-
	R-STUDS-16220	R-STUDS-16220-88	R-STUDS-16220-A4*	16	220	18	101	11
	R-STUDS-16260	-	R-STUDS-16260-A4*	16	260	18	141	51
	R-STUDS-16300	-	R-STUDS-16300-A4*	16	300	18	181	91
	R-STUDS-16380	-	R-STUDS-16380-A4*	16	380	18	261	171
M20	R-STUDS-20260	R-STUDS-20260-88	R-STUDS-20260-A4	20	260	22	117	-
	R-STUDS-20300	R-STUDS-20300-88	R-STUDS-20300-A4*	20	300	22	157	37
	R-STUDS-20350	-	R-STUDS-20350-A4*	20	350	22	207	87
M24	R-STUDS-24300	R-STUDS-24300-88	R-STUDS-24300-A4*	24	300	26	132	-
M30	R-STUDS-30380	R-STUDS-30380-88	R-STUDS-30380-A4	30	380	32	181	-

* Make to order

Installation data

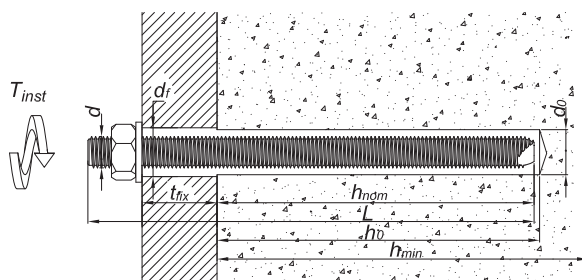

Installation data (cont.)

R-STUDS

Size			M8	M10	M12	M16	M20	M24	M30	
Thread diameter	d	[mm]	8	10	12	16	20	24	30	
Hole diameter in substrate	d ₀	[mm]	10	12	14	18	24	28	35	
Installation torque	T _{inst}	[Nm]	10	20	40	80	120	180	300	
Min. hole depth in substrate	h ₀	[mm]	h _{nom} + 5							
MINIMUM EMBEDMENT DEPTH										
Installation depth	h _{nom,min}	[mm]	60	70	80	100	120	140	165	
MAXIMUM EMBEDMENT DEPTH										
Installation depth	h _{nom,max}	[mm]	100	120	145	190	240	290	360	
Min. substrate thickness	h _{min}	[mm]	h _{nom} + 30				100			
Min. spacing	s _{min}	[mm]	0.5 * h _{nom} ≥ 40							
Min. edge distance	c _{min}	[mm]	0.5 * h _{nom} ≥ 40							

Minimum working and curing time

Resin temperature	Concrete temperature	Working time	Curing time*
[°C]	[°C]	[min]	[min]
5	-5	60	360
5	0	40	180
5	5	20	120
10	10	12	80
15	15	8	60
20	20	5	45
25	30	2	20

*For wet concrete the curing time must be doubled

Mechanical properties

R-STUDS

Size			M8	M10	M12	M16	M20	M24	M30
Nominal ultimate tensile strength - tension	f _{uk}	[N/mm ²]	520	520	520	520	520	520	520
Nominal yield strength - tension	f _{yk}	[N/mm ²]	420	420	420	420	420	420	420
Cross sectional area - tension	A _s	[mm ²]	36.6	58	84.3	157	245	352.8	559.8
Elastic section modulus	W _{el}	[mm ³]	31.2	62.3	109.2	277.5	541	935	1868
Characteristic bending resistance	M ⁰ _{Rk,s}	[Nm]	20	39	68	173	338	583	1166
Design bending resistance	M	[Nm]	11	22	39	99	193	333	666
Nominal ultimate tensile strength - tension	f _{uk}	[N/mm ²]	800	800	800	800	800	800	800
Nominal yield strength - tension	f _{yk}	[N/mm ²]	640	640	640	640	640	640	640
Cross sectional area - tension	A _s	[mm ²]	36.6	58	84.3	157	245	352.8	559.8
Elastic section modulus	W _{el}	[mm ³]	31.2	62.3	109.2	277.5	541	935	1868
Characteristic bending resistance	M ⁰ _{Rk,s}	[Nm]	30	60	105	266	519	898	1793
Design bending resistance	M	[Nm]	17	34	60	152	297	513	1025
Nominal ultimate tensile strength - tension	f _{uk}	[N/mm ²]	700	700	700	700	700	700	700
Nominal yield strength - tension	f _{yk}	[N/mm ²]	350	350	350	350	350	350	350
Cross sectional area - tension	A _s	[mm ²]	36.6	58	84.3	157	245	352.8	559.8
Elastic section modulus	W _{el}	[mm ³]	31.2	62.3	109.2	277.5	541	935	1868
Characteristic bending resistance	M ⁰ _{Rk,s}	[Nm]	26	52	92	233	454	785	1569
Design bending resistance	M	[Nm]	12	24	42	107	208	360	719

Basic performance data

Performance data for single anchor without influence of edge distance and spacing

Size		M8	M10	M12	M16	M20	M24	M30
Substrate		Non-cracked concrete						
CHARACTERISTIC LOAD								
TENSION LOAD N_{Rk}								
R-STUDS METRIC THREADED RODS - STEEL CLASS 5.8								
Minimum embedment depth	[kN]	14.3	22.0	28.7	45.2	64.1	73.9	77.8
Maximum embedment depth	[kN]	18.0	29.0	42.0	78.0	122.0	153.1	169.7
R-STUDS METRIC THREADED RODS - STEEL CLASS 8.8								
Minimum embedment depth	[kN]	14.3	22.0	28.7	45.2	64.1	73.9	77.8
Maximum embedment depth	[kN]	23.9	37.7	51.9	86.0	128.2	153.1	169.7
R-STUDS METRIC THREADED RODS - A4								
Minimum embedment depth	[kN]	14.3	22.0	28.7	45.2	64.1	73.9	77.8
Maximum embedment depth	[kN]	23.9	37.7	51.9	86.0	128.2	153.1	169.7
SHEAR LOAD V_{Rk}								
R-STUDS METRIC THREADED RODS - STEEL CLASS 5.8								
Minimum embedment depth	[kN]	9.00	14.0	21.0	39.0	61.0	88.0	140.0
Maximum embedment depth	[kN]	9.00	14.0	21.0	39.0	61.0	88.0	140.0
R-STUDS METRIC THREADED RODS - STEEL CLASS 8.8								
Minimum embedment depth	[kN]	15.0	23.0	34.0	63.0	98.0	141.0	155.5
Maximum embedment depth	[kN]	15.0	23.0	34.0	63.0	98.0	141.0	224.0
R-STUDS METRIC THREADED RODS - A4								
Minimum embedment depth	[kN]	13.0	20.0	29.0	55.0	86.0	124.0	155.5
Maximum embedment depth	[kN]	13.0	20.0	29.0	55.0	86.0	124.0	196.0
DESIGN LOAD								
TENSION LOAD N_{Rd}								
R-STUDS METRIC THREADED RODS - STEEL CLASS 5.8								
Minimum embedment depth	[kN]	7.96	12.2	15.9	25.1	35.6	35.2	37.0
Maximum embedment depth	[kN]	12.0	19.3	28.0	47.8	71.2	72.9	80.8
R-STUDS METRIC THREADED RODS - STEEL CLASS 8.8								
Minimum embedment depth	[kN]	7.96	12.2	15.9	25.1	35.6	35.2	37.0
Maximum embedment depth	[kN]	13.3	20.9	28.9	47.8	71.2	72.9	80.8
R-STUDS METRIC THREADED RODS - A4								
Minimum embedment depth	[kN]	7.96	12.2	15.9	25.1	35.6	35.2	37.0
Maximum embedment depth	[kN]	13.3	20.9	28.9	47.8	71.2	72.9	80.8
SHEAR LOAD V_{Rd}								
R-STUDS METRIC THREADED RODS - STEEL CLASS 5.8								
Minimum embedment depth	[kN]	7.20	11.2	16.8	31.2	48.8	70.4	103.7
Maximum embedment depth	[kN]	7.20	11.2	16.8	31.2	48.8	70.4	112.0
R-STUDS METRIC THREADED RODS - STEEL CLASS 8.8								
Minimum embedment depth	[kN]	12.0	18.4	27.2	50.4	78.4	98.5	103.7
Maximum embedment depth	[kN]	12.0	18.4	27.2	50.4	78.4	112.8	179.2
R-STUDS METRIC THREADED RODS - A4								
Minimum embedment depth	[kN]	8.33	12.8	18.6	35.3	55.1	79.5	103.7
Maximum embedment depth	[kN]	8.33	12.8	18.6	35.3	55.1	79.5	125.6

Basic performance data (cont.)

Performance data for single anchor without influence of edge distance and spacing

Size		M8	M10	M12	M16	M20	M24	M30
RECOMMENDED LOAD								
TENSION LOAD N_{rec}								
R-STUDS METRIC THREADED RODS - STEEL CLASS 5.8								
Minimum embedment depth	[kN]	5.68	8.73	11.4	18.0	25.4	25.1	26.5
Maximum embedment depth	[kN]	8.57	13.8	20.0	34.1	50.9	52.1	57.7
R-STUDS METRIC THREADED RODS - STEEL CLASS 8.8								
Minimum embedment depth	[kN]	5.68	8.73	11.4	18.0	25.4	25.1	26.5
Maximum embedment depth	[kN]	9.47	15.0	20.6	34.1	50.9	52.1	57.7
R-STUDS METRIC THREADED RODS - A4								
Minimum embedment depth	[kN]	5.68	8.73	11.4	18.0	25.4	25.1	26.5
Maximum embedment depth	[kN]	9.47	15.0	20.6	34.1	50.9	52.1	57.7
SHEAR LOAD V_{Rk}								
R-STUDS METRIC THREADED RODS - STEEL CLASS 5.8								
Minimum embedment depth	[kN]	5.14	8.00	12.0	22.3	34.9	50.3	74.1
Maximum embedment depth	[kN]	5.14	8.00	12.0	22.3	34.9	50.3	80.0
R-STUDS METRIC THREADED RODS - STEEL CLASS 8.8								
Minimum embedment depth	[kN]	8.57	13.1	19.4	36.0	56.0	70.4	74.1
Maximum embedment depth	[kN]	8.57	13.1	19.4	36.0	56.0	80.6	128.0
R-STUDS METRIC THREADED RODS - A4								
Minimum embedment depth	[kN]	5.95	9.16	13.3	25.2	39.4	56.8	74.1
Maximum embedment depth	[kN]	5.95	9.16	13.3	25.2	39.4	56.8	89.7

Product commercial data

Product Code	Volume [ml]	Quantity [pcs]			Weight [kg]			Bar Code	Shelf Life [month]
		Box	Outer	Pallet	Box	Outer	Pallet		
R-CFS+RP30-4	300	1	3	108	2.44	7.32	263.52	5906675205861	18
R-CFS+RP30-600-8	600	1	1	36	8.30	8.30	298.8	5906675085876	18

Resin consumption for bonded anchors

Cartridge size	Stud diameter	d	[mm]	M8	M10	M12	M16	M20	M24	M30
	Hole diameter in substrate	d ₀	[mm]	10	12	14	18	24	28	35
175ml	Reduced Embedment	h_{nom}	[mm]	60	70	80	100	120	140	165
	Quantity of anchored studs			42	28	19	11	4,7	3,2	1,8
	Standard Embedment	h_{nom}	[mm]	80	90	110	125	170	210	240
	Quantity of anchored studs			32	22	14	9	3,4	4	2,1
	Maximum Embedment	h_{nom}	[mm]	100	120	145	190	240	290	360
Quantity of anchored studs			26	17	11	6	2,4	1,6	0,8	
280 ml	Reduced Embedment	h_{nom}	[mm]	60	70	80	100	120	140	165
	Quantity of anchored studs			73	49	34	19	8,3	5,6	3,1
	Standard Embedment	h_{nom}	[mm]	80	90	110	125	170	210	240
	Quantity of anchored studs			57	39	26	16	6,0	3,8	2,2
	Maximum Embedment	h_{nom}	[mm]	100	120	145	190	240	290	360
Quantity of anchored studs			46	30	20	10	4,3	2,8	1,5	
300 ml	Reduced Embedment	h_{nom}	[mm]	60	70	80	100	120	140	165
	Quantity of anchored studs			79	53	37	21	9,0	6,0	3,4
	Standard Embedment	h_{nom}	[mm]	80	90	110	125	170	210	240
	Quantity of anchored studs			61	42	28	17	6,5	4,1	2,4
	Maximum Embedment	h_{nom}	[mm]	100	120	145	190	240	290	360
Quantity of anchored studs			50	32	21	11	4,6	3,0	1,6	
310 ml	Reduced Embedment	h_{nom}	[mm]	60	70	80	100	120	140	165
	Quantity of anchored studs			82	55	38	22	9,3	6,3	3,5
	Standard Embedment	h_{nom}	[mm]	80	90	110	125	170	210	240
	Quantity of anchored studs			64	44	29	18	6,7	4,3	2,4
	Maximum Embedment	h_{nom}	[mm]	100	120	145	190	240	290	360
Quantity of anchored studs			52	33	22	12	4,8	3,1	1,6	
345 ml	Reduced Embedment	h_{nom}	[mm]	60	70	80	100	120	140	165
	Quantity of anchored studs			93	62	43	24	10,5	7,1	4,0
	Standard Embedment	h_{nom}	[mm]	80	90	110	125	170	210	240
	Quantity of anchored studs			72	49	32	20	7,6	4,8	2,8
	Maximum Embedment	h_{nom}	[mm]	100	120	145	190	240	290	360
Quantity of anchored studs			59	38	25	13	5,4	3,5	1,9	
380 ml	Reduced Embedment	h_{nom}	[mm]	60	70	80	100	120	140	165
	Quantity of anchored studs			104	69	48	27	11,7	7,9	4,4
	Standard Embedment	h_{nom}	[mm]	80	90	110	125	170	210	240
	Quantity of anchored studs			80	55	36	22	8,4	5,4	3,1
	Maximum Embedment	h_{nom}	[mm]	100	120	145	190	240	290	360
Quantity of anchored studs			65	42	28	15	6,1	3,9	2,1	
385 ml	Reduced Embedment	h_{nom}	[mm]	60	70	80	100	120	140	165
	Quantity of anchored studs			105	70	49	28	11,8	8,0	4,5
	Standard Embedment	h_{nom}	[mm]	80	90	110	125	170	210	240
	Quantity of anchored studs			81	56	37	22	8,5	5,4	3,1
	Maximum Embedment	h_{nom}	[mm]	100	120	145	190	240	290	360
Quantity of anchored studs			66	43	28	15	6,1	4,0	2,1	

GLASS CAPSULES

- R-CAS-V
 - Spin-In Capsule with Threaded Rods
- R-HAC-V
 - Hammer-In with Threaded Rods
 - Hammer-In with Rebar

Quick and easy to install by hammering or spinning in stud or rebar

Rounded capsule tip for insertion into the hole

Spin-in and Hammer-in capsules

Capsule contains a precise volume of resin and hardener. No waste packaging

Drill/hole diameter, stud size indicated on the capsule



R-CAS-V Spin-In Capsule with Threaded Rods

High-performance, quick-setting, styrene-free vinylester resin for concrete



Approvals and Reports

- ETA-10/0108



Installation movie

Product overview

Features and benefits

- Approved for use with threaded rods in non-cracked concrete
- High performance for use safety critical application - heavy-duty fastenings with small spacing and edge distances
- The system relies on the adhesion between the concrete and resin, which is free from expansion forces. This makes it an ideal choice where close edge and spacing distances are required
- Capsule contains a precise volume of constituents making it a very consistent product
- Suitable for making fixings underwater. Adhesive strength is not affected by unpolluted water
- Suitable for dry or wet non-cracked concrete
- Styrene free - odourless

Applications

- Threaded rods
- Balustrading
- Railings
- Heavy machinery
- Structural steel
- Steel columns
- Cladding restraints
- Curtain walling
- Fencing & gates
- Formwork supports
- Garage doors
- Guard rails

Base materials

Approved for use in:

- Non-cracked concrete C20/25-C50/60

Installation guide

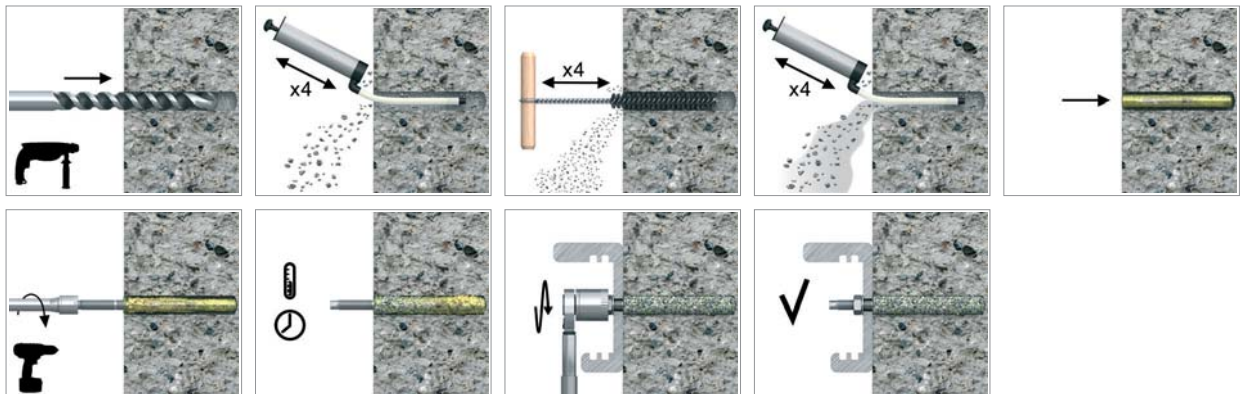

Installation guide (cont.)

1. Drill hole to the required diameter and depth for capsule size being used.
2. Clean the hole thoroughly with brush and hand pump at least four times before installation.
3. Insert capsule into the hole. Connect stud to drilling machine using appropriate driver system.
4. Position the stud into the glass capsule then switch on the drilling machine and drive stud into the capsule.
Switch off the drilling machine as soon as the bottom of hole is reached.
5. Leave the anchor undisturbed until the curing time elapses.
6. Attach fixture and tighten the nut to the required torque.

Product information

Size	Product Code	Description / Resin Type
M8	R-CAS-V-08	Styrene Free Vinylester Resin
M10	R-CAS-V-10	
M12	R-CAS-V-12	
M16	R-CAS-V-16	
M20	R-CAS-V-20	
M24	R-CAS-V-24	
M30	R-CAS-V-30	

R-STUDS

Size	Product Code			Anchor		Fixture	
	Steel class 5.8	Steel class 8.8	Steel grade A4	Diameter	Length	Hole diameter	Max. thickness t_{fix} for:
				d	L	d_f	$h_{nom, std}$
				[mm]	[mm]	[mm]	[mm]
M8	R-STUDS-08110	R-STUDS-08110-88	R-STUDS-08110-A4	8	110	9	20
	R-STUDS-08160	-	R-STUDS-08160-A4	8	160	9	70
M10	R-STUDS-10130	R-STUDS-10130-88	R-STUDS-10130-A4	10	130	12	28
	R-STUDS-10170	-	R-STUDS-10170-A4	10	170	12	68
	R-STUDS-10190	-	R-STUDS-10190-A4	10	190	12	88
M12	R-STUDS-12160	R-STUDS-12160-88	R-STUDS-12160-A4	12	160	14	35
	R-STUDS-12190	-	R-STUDS-12190-A4	12	190	14	65
	R-STUDS-12220	-	R-STUDS-12220-A4	12	220	14	95
	R-STUDS-12260	-	R-STUDS-12260-A4	12	260	14	135
	R-STUDS-12300	-	R-STUDS-12300-A4	12	300	14	175
M16	R-STUDS-16190	R-STUDS-16190-88	R-STUDS-16190-A4	16	190	18	46
	R-STUDS-16220	R-STUDS-16220-88	R-STUDS-16220-A4	16	220	18	76
	R-STUDS-16260	-	R-STUDS-16260-A4	16	260	18	116
	R-STUDS-16300	-	R-STUDS-16300-A4	16	300	18	156
	R-STUDS-16380	-	R-STUDS-16380-A4	16	380	18	236
M20	R-STUDS-20260	R-STUDS-20260-88	R-STUDS-20260-A4	20	260	22	67
	R-STUDS-20300	-	R-STUDS-20300-A4	20	300	22	107
	R-STUDS-20350	-	R-STUDS-20350-A4	20	350	22	157
M24	R-STUDS-24300	R-STUDS-24300-88	R-STUDS-24300-A4	24	300	26	62
M30	R-STUDS-30380	R-STUDS-30380-88	R-STUDS-30380-A4	30	380	32	106

* Make to order

Installation data

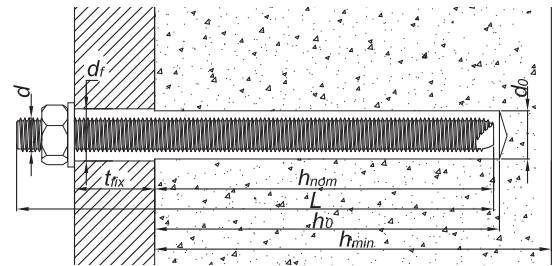
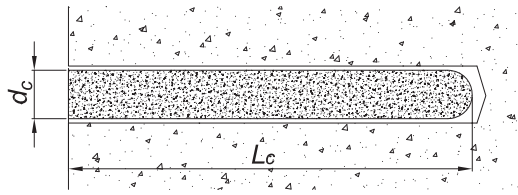

R-STUDS

Size			M8	M10	M12	M16	M20	M24	M30
Thread diameter	d	[mm]	8	10	12	16	20	24	30
Hole diameter in substrate	d ₀	[mm]	10	12	14	18	24	28	35
Installation torque	T _{inst}	[Nm]	10	20	40	80	120	180	300
Min. hole depth in substrate	h ₀	[mm]	h _{nom} + 5						
Installation depth	h _{nom}	[mm]	80	90	110	125	170	210	270
Min. substrate thickness	h _{min}	[mm]	120	130	140	180	230	270	340
Min. spacing	s _{min}	[mm]	0.5 * h _{nom} 40						
Min. edge distance	c _{min}	[mm]	0.5 * h _{nom} 40						

Minimum working and curing time

Resin temperature	Concrete temperature	Working time	Curing time*
[°C]	[°C]	[min]	[min]
5	-5	-	480
5	0	-	240
5	5	-	150
10	10	-	120
15	15	-	90
20	20	-	45
25	30	-	20
25	40	-	10

*For wet concrete the curing time must be doubled

Mechanical properties

R-STUDS

Size			M8	M10	M12	M16	M20	M24	M30
R-STUDS METRIC THREADED RODS - steel class 5.8									
Nominal ultimate tensile strength - tension	F _{uk}	[N/mm ²]	520	520	520	520	520	520	520
Nominal yield strength - tension	F _{yk}	[N/mm ²]	420	420	420	420	420	420	420
Cross sectional area - tension	A _s	[mm ²]	36.6	58	84.3	157	245	352.8	559.8
Elastic section modulus	W _{el}	[mm ³]	31.2	62.3	109.2	277.5	541	935	1868
Characteristic bending resistance	M ⁰ _{Rk,s}	[Nm]	20	39	68	173	338	583	1166
Design bending resistance	M	[Nm]	11	22	39	99	193	333	666
R-STUDS METRIC THREADED RODS - steel class 8.8									
Nominal ultimate tensile strength - tension	F _{uk}	[N/mm ²]	800	800	800	800	800	800	800
Nominal yield strength - tension	F _{yk}	[N/mm ²]	640	640	640	640	640	640	640
Cross sectional area - tension	A _s	[mm ²]	36.6	58	84.3	157	245	352.8	559.8
Elastic section modulus	W _{el}	[mm ³]	31.2	62.3	109.2	277.5	541	935	1868
Characteristic bending resistance	M ⁰ _{Rk,s}	[Nm]	30	60	105	266	519	898	1793
Design bending resistance	M	[Nm]	17	34	60	152	297	513	1025
R-STUDS METRIC THREADED RODS - A4									
Nominal ultimate tensile strength - tension	F _{uk}	[N/mm ²]	700	700	700	700	700	700	700
Nominal yield strength - tension	F _{yk}	[N/mm ²]	350	350	350	350	350	350	350
Cross sectional area - tension	A _s	[mm ²]	36.6	58	84.3	157	245	352.8	559.8
Elastic section modulus	W _{el}	[mm ³]	31.2	62.3	109.2	277.5	541	935	1868
Characteristic bending resistance	M ⁰ _{Rk,s}	[Nm]	26	52	92	233	454	785	1569
Design bending resistance	M	[Nm]	12	24	42	107	208	360	719

Basic performance data

Performance data for single anchor without influence of edge distance and spacing

Size		M8	M10	M12	M16	M20	M24	M30
Substrate		Non-cracked concrete						
Embedment depth h_{ef}	[mm]	80	90	110	125	170	210	270
CHARACTERISTIC LOAD								
TENSION LOAD N_{rk}								
R-STUDS METRIC THREADED RODS - STEEL CLASS 5.8	[kN]	18.0	29.0	42.0	60.0	95.0	140.0	200.0
R-STUDS METRIC THREADED RODS - STEEL CLASS 8.8	[kN]	25.0	30.0	50.0	60.0	95.0	140.0	200.0
R-STUDS METRIC THREADED RODS - A4	[kN]	25.0	30.0	50.0	60.0	95.0	140.0	200.0
SHEAR LOAD V_{rk}								
R-STUDS METRIC THREADED RODS - STEEL CLASS 5.8	[kN]	9.00	14.0	21.0	39.0	61.0	88.0	140.0
R-STUDS METRIC THREADED RODS - STEEL CLASS 8.8	[kN]	15.0	23.0	34.0	63.0	98.0	141.0	224.0
R-STUDS METRIC THREADED RODS - A4	[kN]	13.0	20.0	29.0	55.0	86.0	124.0	196.0
DESIGN LOAD								
TENSION LOAD N_{rd}								
R-STUDS METRIC THREADED RODS - STEEL CLASS 5.8	[kN]	12.0	16.7	27.8	33.3	52.8	77.8	111.1
R-STUDS METRIC THREADED RODS - STEEL CLASS 8.8	[kN]	13.9	16.7	27.8	33.3	52.8	77.8	111.1
R-STUDS METRIC THREADED RODS - A4	[kN]	13.9	16.7	27.8	33.3	52.8	77.8	111.1
SHEAR LOAD V_{rd}								
R-STUDS METRIC THREADED RODS - STEEL CLASS 5.8	[kN]	7.20	11.2	16.8	31.2	48.8	70.4	112.0
R-STUDS METRIC THREADED RODS - STEEL CLASS 8.8	[kN]	12.0	18.4	27.2	50.4	78.4	112.8	179.2
R-STUDS METRIC THREADED RODS - A4	[kN]	8.33	12.8	18.6	35.3	55.1	79.5	125.6
RECOMMENDED LOAD								
TENSION LOAD N_{rec}								
R-STUDS METRIC THREADED RODS - STEEL CLASS 5.8	[kN]	8.57	11.9	19.8	23.8	37.7	55.6	79.4
R-STUDS METRIC THREADED RODS - STEEL CLASS 8.8	[kN]	9.92	11.9	19.8	23.8	37.7	55.6	79.4
R-STUDS METRIC THREADED RODS - A4	[kN]	9.92	11.9	19.8	23.8	37.7	55.6	79.4
SHEAR LOAD V_{rec}								
R-STUDS METRIC THREADED RODS - STEEL CLASS 5.8	[kN]	5.14	8.00	12.0	22.3	34.9	50.3	80.0
R-STUDS METRIC THREADED RODS - STEEL CLASS 8.8	[kN]	8.57	13.1	19.4	36.0	56.0	80.6	128.0
R-STUDS METRIC THREADED RODS - A4	[kN]	5.95	9.16	13.3	25.2	39.4	56.8	89.7

Product commercial data

Product Code	Size	Quantity [pcs]			Weight [kg]			Bar Code	Shelf Life [month]
		Box	Outer	Pallet	Box	Outer	Pallet		
R-CAS-V-08	M8	10	480	5760	0.16	7.7	121.9	5906675280189	18
R-CAS-V-10	M10	10	480	5760	0.21	10.0	150.2	5906675280196	18
R-CAS-V-12	M12	10	480	5760	0.26	12.7	182.3	5906675280202	18
R-CAS-V-16	M16	10	480	5760	0.38	18.0	246.1	5906675280219	18
R-CAS-V-20	M20	6	108	1296	0.78	14.1	199.0	5906675280226	18
R-CAS-V-24	M24	6	108	1296	1.04	18.8	255.3	5906675280233	18
R-CAS-V-30	M30	4	32	384	1.75	14.0	197.8	5906675280240	18

R-HAC-V Hammer-In with Threaded Rods

Heavy duty anchor with small spacing and edge distances, simply installed by hammering the threaded rods



Approvals and Reports

- ETA-11/0002



Installation movie

Product overview

Features and benefits

- High performance anchor, for use in safety critical applications
- The system relies on the adhesion between concrete and resin, which is free from expansion forces. This makes it an ideal choice where close edge and spacing distances are required
- Capsule contains precise amounts of ingredients making it a very consistent product
- Adhesive bond strength is not affected by unpolluted water
- Suitable for dry or wet non-cracked concrete
- Low cost tooling required for installation, quick and easy to install
- Styrene free - virtually odourless
- Approved for use with threaded rods in non-cracked concrete

Applications

- Balustrading & handrails
- Cable trays
- Guard rails
- Machinery
- Threaded rods
- Cladding restraints
- Curtain walling
- Fencing & gates

Base materials

Approved for use in:

- Non-cracked concrete C20/25-C50/60

Also suitable for use in:

- Natural Stone

Installation guide

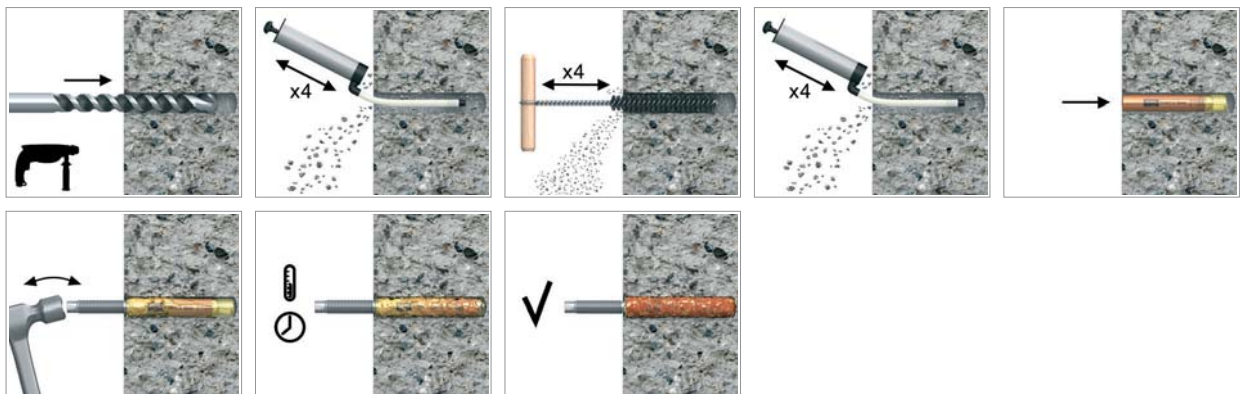

Installation guide (cont.)

1. Drill hole to the required diameter and depth for stud size being used.
2. Clean the hole thoroughly with brush and hand pump at least four times before installation.
3. Insert capsule into the hole.
4. The stud is simply hammered through the capsule using a manual or mechanical hammer (M16-M30).
5. Leave the anchor undisturbed until the curing time elapses.
6. Attach fixture and tighten the nut to the required torque.

Product information

Size	Product Code	Description / Resin Type
M8	R-HAC-V-08	Styrene Free Vinylester Resin
M10	R-HAC-V-10	
M12	R-HAC-V-12	
M16	R-HAC-V-16	
M20	R-HAC-V-20	
M24	R-HAC-V-24	
M30	R-HAC-V-30	

R-STUDS

Size	Product Code			Anchor		Fixture	
	Steel class 5.8	Steel class 8.8	Steel grade A4	Diameter	Length	Hole diameter	Max. thickness t_{fix}
				d	L	d_f	$h_{nom,Std}$
				[mm]	[mm]	[mm]	[mm]
M8	R-STUDS-08110	R-STUDS-08110-88	R-STUDS-08110-A4	8	110	9	20
	R-STUDS-08160	-	R-STUDS-08160-A4	8	160	9	70
M10	R-STUDS-10130	R-STUDS-10130-88	R-STUDS-10130-A4	10	130	12	28
	R-STUDS-10170	-	R-STUDS-10170-A4	10	170	12	68
	R-STUDS-10190	-	R-STUDS-10190-A4	10	190	12	88
M12	R-STUDS-12160	R-STUDS-12160-88	R-STUDS-12160-A4	12	160	14	35
	R-STUDS-12190	-	R-STUDS-12190-A4	12	190	14	65
	R-STUDS-12220	-	R-STUDS-12220-A4	12	220	14	95
	R-STUDS-12260	-	R-STUDS-12260-A4	12	260	14	135
	R-STUDS-12300	-	R-STUDS-12300-A4	12	300	14	175
M16	R-STUDS-16190	R-STUDS-16190-88	R-STUDS-16190-A4	16	190	18	46
	R-STUDS-16220	R-STUDS-16220-88	R-STUDS-16220-A4	16	220	18	76
	R-STUDS-16260	-	R-STUDS-16260-A4	16	260	18	116
	R-STUDS-16300	-	R-STUDS-16300-A4	16	300	18	156
	R-STUDS-16380	-	R-STUDS-16380-A4	16	380	18	236
M20	R-STUDS-20260	R-STUDS-20260-88	R-STUDS-20260-A4	20	260	22	67
	R-STUDS-20300	-	R-STUDS-20300-A4	20	300	22	107
	R-STUDS-20350	-	R-STUDS-20350-A4	20	350	22	157
M24	R-STUDS-24300	R-STUDS-24300-88	R-STUDS-24300-A4	24	300	26	62
M30	R-STUDS-30380	R-STUDS-30380-88	R-STUDS-30380-A4	30	380	32	106

* Make to order

Installation data

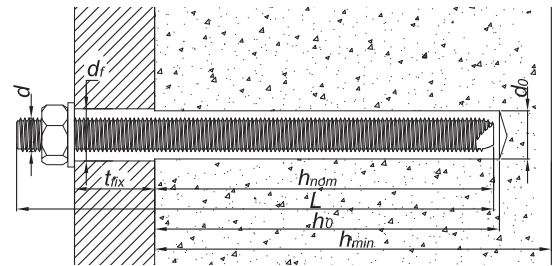
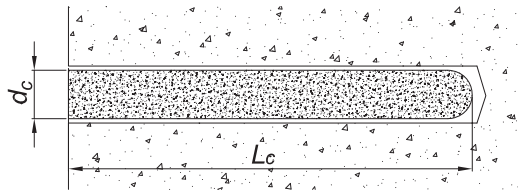

R-STUDS

Size	M8	M10	M12	M16	M20	M24	M30		
Thread diameter	d	[mm]	8	10	12	16	20	24	30
Hole diameter in substrate	do	[mm]	10	12	14	18	24	28	35
Installation torque	Tinst	[Nm]	10	20	40	80	120	180	300
Min. hole depth in substrate	ho	[mm]	hnom + 5						
Installation depth	hnom	[mm]	80	90	110	125	170	210	270
Min. substrate thickness	hmin	[mm]	120	130	140	180	230	270	340
Min. spacing	Smin	[mm]	0.5 * hnom ≥ 40						
Min. edge distance	Cmin	[mm]	0.5 * hnom ≥ 40						

Minimum working and curing time

Resin temperature	Concrete temperature	Working time	Curing time*
[°C]	[°C]	[min]	[min]
5	-5	-	1440
5	0	-	840
5	5	-	240
10	10	-	180
15	15	-	90
20	20	-	45
25	30	-	20
25	40	-	10

*For wet concrete the curing time must be doubled

Mechanical properties

R-STUDS

Size	M8	M10	M12	M16	M20	M24	M30		
R-STUDS METRIC THREADED RODS - steel class 5.8									
Nominal ultimate tensile strength - tension	F _{uk}	[N/mm ²]	520	520	520	520	520		
Nominal yield strength - tension	F _{yk}	[N/mm ²]	420	420	420	420	420		
Cross sectional area - tension	A _s	[mm ²]	36.6	58	84.3	157	245	352.8	559.8
Elastic section modulus	W _{el}	[mm ³]	31.2	62.3	109.2	277.5	541	935	1868
Characteristic bending resistance	M ⁰ _{Rk,s}	[Nm]	20	39	68	173	338	583	1166
Design bending resistance	M	[Nm]	11	22	39	99	193	333	666
R-STUDS METRIC THREADED RODS - steel class 8.8									
Nominal ultimate tensile strength - tension	F _{uk}	[N/mm ²]	800	800	800	800	800	800	
Nominal yield strength - tension	F _{yk}	[N/mm ²]	640	640	640	640	640	640	
Cross sectional area - tension	A _s	[mm ²]	36.6	58	84.3	157	245	352.8	559.8
Elastic section modulus	W _{el}	[mm ³]	31.2	62.3	109.2	277.5	541	935	1868
Characteristic bending resistance	M ⁰ _{Rk,s}	[Nm]	30	60	105	266	519	898	1793
Design bending resistance	M	[Nm]	17	34	60	152	297	513	1025
R-STUDS METRIC THREADED RODS - A4									
Nominal ultimate tensile strength - tension	F _{uk}	[N/mm ²]	700	700	700	700	700	700	
Nominal yield strength - tension	F _{yk}	[N/mm ²]	350	350	350	350	350	350	
Cross sectional area - tension	A _s	[mm ²]	36.6	58	84.3	157	245	352.8	559.8
Elastic section modulus	W _{el}	[mm ³]	31.2	62.3	109.2	277.5	541	935	1868
Characteristic bending resistance	M ⁰ _{Rk,s}	[Nm]	26	52	92	233	454	785	1569
Design bending resistance	M	[Nm]	12	24	42	107	208	360	719

Basic performance data

R-STUDS

Performance data for single anchor without influence of edge distance and spacing

Size		M8	M10	M12	M16	M20	M24	M30
Substrate		Non-cracked concrete						
Embedment depth h_{nom}	[mm]	80	90	110	125	170	210	270
CHARACTERISTIC LOAD								
TENSION LOAD N_{Rk}								
R-STUDS METRIC THREADED RODS - STEEL CLASS 5.8	[kN]	18.0	25.0	40.0	50.0	95.0	115.0	170.0
R-STUDS METRIC THREADED RODS - STEEL CLASS 8.8	[kN]	20.0	25.0	40.0	50.0	95.0	115.0	170.0
R-STUDS METRIC THREADED RODS - A4	[kN]	20.0	25.0	40.0	50.0	95.0	115.0	170.0
SHEAR LOAD V_{Rk}								
R-STUDS METRIC THREADED RODS - STEEL CLASS 5.8	[kN]	9.0	14.0	21.0	39.0	61.0	88.0	140.0
R-STUDS METRIC THREADED RODS - STEEL CLASS 8.8	[kN]	15.0	23.0	34.0	63.0	98.0	141.0	224.0
R-STUDS METRIC THREADED RODS - A4	[kN]	13.0	20.0	29.0	55.0	86.0	124.0	196.0
DESIGN LOAD								
TENSION LOAD N_{Rd}								
R-STUDS METRIC THREADED RODS - STEEL CLASS 5.8	[kN]	9.52	11.9	22.2	23.8	45.2	54.8	81.0
R-STUDS METRIC THREADED RODS - STEEL CLASS 8.8	[kN]	9.52	11.9	22.2	23.8	45.2	54.8	81.0
R-STUDS METRIC THREADED RODS - A4	[kN]	9.52	11.9	22.2	23.8	45.2	54.8	81.0
SHEAR LOAD V_{Rd}								
R-STUDS METRIC THREADED RODS - STEEL CLASS 5.8	[kN]	7.20	11.2	16.8	31.2	48.8	70.4	112.0
R-STUDS METRIC THREADED RODS - STEEL CLASS 8.8	[kN]	12.0	18.4	27.2	50.4	78.4	112.8	179.2
R-STUDS METRIC THREADED RODS - A4	[kN]	8.33	12.8	18.6	35.3	55.1	79.5	125.6
RECOMMENDED LOAD								
TENSION LOAD N_{rec}								
R-STUDS METRIC THREADED RODS - STEEL CLASS 5.8	[kN]	6.80	8.50	15.90	17.00	32.30	39.10	57.80
R-STUDS METRIC THREADED RODS - STEEL CLASS 8.8	[kN]	6.80	8.50	15.90	17.00	32.30	39.10	57.80
R-STUDS METRIC THREADED RODS - A4	[kN]	6.80	8.50	15.90	17.00	32.30	39.10	57.80
SHEAR LOAD V_{rec}								
R-STUDS METRIC THREADED RODS - STEEL CLASS 5.8	[kN]	5.14	8.00	12.0	22.3	34.9	50.3	80.0
R-STUDS METRIC THREADED RODS - STEEL CLASS 8.8	[kN]	8.57	13.1	19.4	36.0	56.0	80.6	128.0
R-STUDS METRIC THREADED RODS - A4	[kN]	5.95	9.16	13.3	25.2	39.4	56.8	89.7

Product commercial data

Product Code	Quantity [pcs]			Weight [kg]			Bar Code
	Box	Outer	Pallet	Box	Outer	Pallet	
R-HAC-V-08	10	480	5760	0.15	7.1	115.5	5906675377827
R-HAC-V-10	10	480	5760	0.17	8.2	128.1	5906675379913
R-HAC-V-12	10	480	5760	0.21	10.2	152.0	5906675379920
R-HAC-V-16	10	480	5760	0.29	13.8	195.7	5906675379937
R-HAC-V-20	6	108	1296	0.56	10.1	151.7	5906675379944
R-HAC-V-24	6	108	1296	0.75	13.4	191.1	5906675379951
R-HAC-V-30	4	32	384	1.19	9.6	144.7	5906675379968

R-HAC-V Hammer-In with Rebar

Heavy duty anchor with small spacing and edge distances, simply installed by hammering the rebar



Approvals and Reports

- ETA-11/0002



Installation movie

Product overview

Features and benefits

- Approved for use with rebar in non-cracked concrete (ETAG001 Option 7)
- High performance anchor, for use in safety critical applications
- The system relies on the adhesion between concrete and resin, which is free from expansion forces. This makes it an ideal choice where close edge and spacing distances are required
- Capsule contains precise amounts of ingredients making it a very consistent product
- Adhesive bond strength is not affected by unpolluted water
- Suitable for dry or wet non-cracked concrete
- Ideal for starter bar applications
- Low cost tooling required for installation, quick and easy to install
- Styrene free - virtually odourless

Applications

- Reinforcement bars
- Cable trays
- Heavy machinery
- Fencing & gates manufacturing and installation
- Formwork support systems

Base materials

Approved for use in:

- Non-cracked concrete C20/25-C50/60

Also suitable for use in:

- Natural Stone

Installation guide

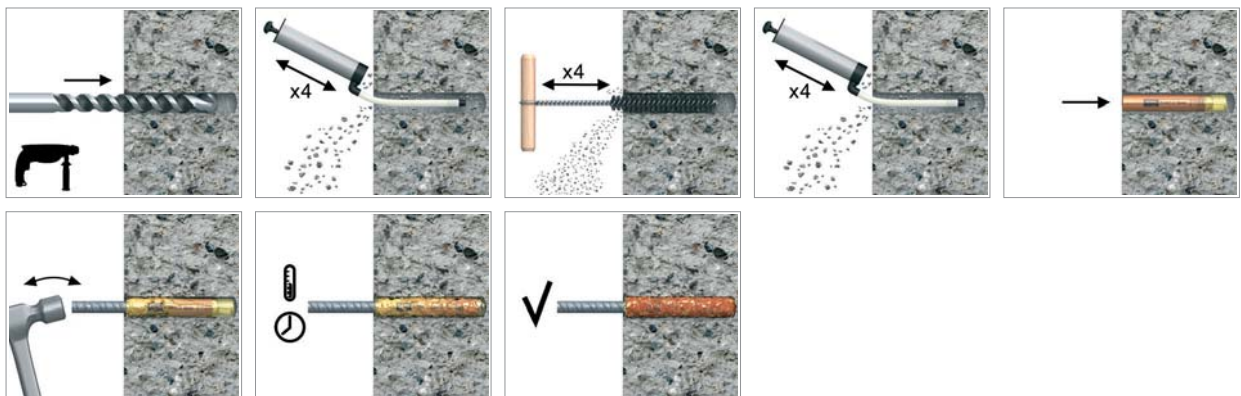

Installation guide (cont.)

1. Drill hole to the required diameter and depth for stud size being used.
2. Clean the hole thoroughly with brush and hand pump at least four times before installation.
3. Insert capsule into the hole.
4. The stud is simply hammered through the capsule using a manual hammer.
5. Leave the anchor undisturbed until the curing time elapses.

Product information

Product Code	Description / Resin Type
R-HAC-V-08	Styrene Free Vinylester Resin
R-HAC-V-10	
R-HAC-V-12	
R-HAC-V-16	
R-HAC-V-20	
R-HAC-V-24	
R-HAC-V-30	

Installation data

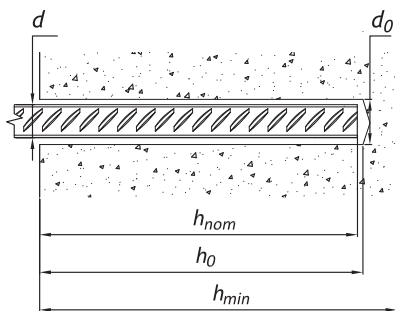

REBARS

Size		Ø08	Ø10	Ø12	Ø14	Ø16	Ø20	Ø25
Rebar diameter	d_s [mm]	8	10	12	14	16	20	25
Hole diameter in substrate	d_0 [mm]	12	14	16	18	22	26	35
Min. hole depth in substrate	h_0 [mm]	85	95	115	130	175	215	275
Embedment depth	h_{nom} [mm]	80	90	110	125	170	210	270
Min. spacing	s_{min} [mm]	40	45	55	62	85	105	135
Min. edge distance	c_{min} [mm]	40	45	55	62	85	105	135

Minimum working and curing time

Resin temperature	Concrete temperature	Working time	Curing time*
[°C]	[°C]	[min]	[min]
5	-5	-	1440
5	0	-	840
5	5	-	240
10	10	-	180
15	15	-	90
20	20	-	45
25	30	-	20
25	40	-	10

*For wet concrete the curing time must be doubled

Mechanical properties

REBARS

Size			Ø8	Ø10	Ø12	Ø14	Ø16	Ø20	Ø25
f_{uk} = 540 (e.g. 500 B acc. to BS 4449; B 500 B acc. to SS 560)									
Nominal ultimate tensile strength - tension	f _{uk}	[N/mm ²]	540	540	540	540	540	540	540
Nominal yield strength - tension	f _{yk}	[N/mm ²]	500	500	500	500	500	500	500
Cross sectional area - tension	A _s	[mm ²]	50.3	78.5	113.1	153.9	201.1	314.2	490.9
Elastic section modulus	W _{el}	[mm ³]	50.3	98.2	169.6	269.4	402.1	785.4	1534
f_{uk} = 575 (e.g. B 500 SP acc. to EC2)									
Nominal ultimate tensile strength - tension	f _{uk}	[N/mm ²]	575	575	575	575	575	575	575
Nominal yield strength - tension	f _{yk}	[N/mm ²]	500	500	500	500	500	500	500
Cross sectional area - tension	A _s	[mm ²]	50.3	78.5	113.1	153.9	201.1	314.2	490.9
Elastic section modulus	W _{el}	[mm ³]	50.3	98.2	169.6	269.4	402.1	785.4	1534
f_{uk} = 620 (e.g. G-60 acc. to ASTM 615)									
Nominal ultimate tensile strength - tension	f _{uk}	[N/mm ²]	620	620	620	620	620	620	620
Nominal yield strength - tension	f _{yk}	[N/mm ²]	420	420	420	420	420	420	420
Cross sectional area - tension	A _s	[mm ²]	50.3	78.5	113.1	153.9	201.1	314.2	490.9
Elastic section modulus	W _{el}	[mm ³]	50.3	98.2	169.6	269.4	402.1	785.4	1534

Basic performance data

Performance data for single anchor without influence of edge distance and spacing

Size		Ø8	Ø10	Ø12	Ø14	Ø16	Ø20	Ø25
Substrate		Non-cracked concrete						
CHARACTERISTIC LOAD								
TENSION LOADS N _{rk}								
A-II (18G2)								
Standard Embedment Depth	[kN]	16.0	20.0	30.0	40.0	50.0	60.0	95.0
A-III (34GS)								
Standard Embedment Depth	[kN]	16.0	20.0	30.0	40.0	50.0	60.0	95.0
A-IIIN (RB500, BSt500S, B500SP)								
Standard Embedment Depth	[kN]	16.0	20.0	30.0	40.0	50.0	60.0	95.0
SHEAR LOADS V _{rk}								
A-II (18G2)	[kN]	12.1	18.8	27.1	36.9	48.3	75.4	117.8
A-III (34GS)	[kN]	12.6	19.6	28.3	38.5	50.3	78.5	122.7
A-IIIN (RB500, BSt500S, B500SP)	[kN]	13.8	21.6	31.1	42.3	55.3	86.4	135.0
DESIGN LOAD								
TENSION LOADS N _{Rd}								
A-II (18G2)								
Standard Embedment Depth	[kN]	8.9	11.1	16.7	22.2	27.8	33.3	52.8
A-III (34GS)								
Standard Embedment Depth	[kN]	8.9	11.1	16.7	22.2	27.8	33.3	52.8
A-IIIN (RB500, BSt500S, B500SP)								
Standard Embedment Depth	[kN]	8.9	11.1	16.7	22.2	27.8	33.3	52.8
SHEAR LOADS V _{Rd}								
A-II (18G2)	[kN]	8.0	12.6	18.1	24.6	32.2	50.3	78.5
A-III (34GS)	[kN]	8.4	13.1	18.8	25.7	33.5	52.4	81.8
A-IIIN (RB500, BSt500S, B500SP)	[kN]	9.2	14.4	20.7	28.2	36.9	57.6	90.0

Basic performance data (cont.)

R-STUDS

Size		Ø8	Ø10	Ø12	Ø14	Ø16	Ø20	Ø25
Substrate		Non-cracked concrete						
RECOMMENDED LOAD*								
TENSION LOADS N_{rec}								
A-II (18G2)								
Standard Embedment Depth	[kN]	6.35	7.9	11.9	15.9	19.8	23.8	37.7
A-III (34GS)								
Standard Embedment Depth	[kN]	6.35	7.9	11.9	15.9	19.8	23.8	37.7
A-IIIN (RB500, BSt500S, B500SP)								
Standard Embedment Depth	[kN]	6.35	7.9	11.9	15.9	19.8	23.8	37.7
SHEAR LOADS V_{rec}								
A-II (18G2)								
	[kN]	5.74	8.98	12.9	17.6	23.0	35.9	56.1
A-III (34GS)								
	[kN]	5.98	9.35	13.5	18.3	23.9	37.4	58.4
A-IIIN (RB500, BSt500S, B500SP)								
	[kN]	6.58	10.3	14.8	20.2	26.3	41.1	64.3

Product commercial data

Product Code	Quantity [pcs]			Weight [kg]			Bar Codes
	Box	Outer	Pallet	Box	Outer	Pallet	
R-HAC-V-08 ¹⁾	10	480	5760	0.15	7.1	115.5	5906675377827
R-HAC-V-10 ¹⁾	10	480	5760	0.17	8.2	128.1	5906675379913
R-HAC-V-12 ¹⁾	10	480	5760	0.21	10.2	152.0	5906675379920
R-HAC-V-16 ¹⁾	10	480	5760	0.29	13.8	195.7	5906675379937
R-HAC-V-20 ¹⁾	6	108	1296	0.56	10.1	151.7	5906675379944
R-HAC-V-24 ¹⁾	6	108	1296	0.75	13.4	191.1	5906675379951
R-HAC-V-30 ¹⁾	4	32	384	1.19	9.6	144.7	5906675379968

1) ETA-11/0002

ACCESSORIES

- R-STUDS
- R-ITS
- R-BRUSH
- R-BLOWPUMP
- Plastic and Wire Mesh Sleeves R-PLS
- R-NOZ Mixer Nozzles
- R-GUN Dispenser Guns



R-STUDS Threaded Rods with Hexagonal or Flat Head

Threaded rod with hexagonal or flat head for use with bonded anchors.



Hexagonal Head



Flat Head



Product overview

Features and benefits

- High load-bearing capacities when used with Rawlplug high-performance bonded anchor resins
- Hexagonal head for convenient use with torque wrench
- Flat head for quick manual installation
- A4 stainless steel version for use outdoors and in damp conditions
- Class 8.8 carbon steel version offers improved load-bearing capacities (relative to standard carbon steel)
- Suitable for use with special mesh sleeves in hollow substrates
- Can be post-installed through fixture in some cases. (Consult technical advisory service)
- Possibility of removal when used with internally threaded socket

Applications

- Balustrading & handrails
- Supports
- Barriers
- Racking systems
- Consoles
- Railings
- Window elements
- Scaffolding
- Machinery
- Facades
- Copy-eco systems
- Cable trays
- Curtain walling
- Formwork supports
- Heavy machinery
- Lamps
- Safety barriers
- Road Signs
- Railings
- Public seating

Installation guide



1. Drill hole to the required diameter and depth for stud size being used.
2. Clean the hole thoroughly with hand pump and hole brush
3. If required, insert the mesh sleeve into position
4. Fill hole with the required resin to the recommended fill level. (Follow the relevant instructions for the resin product)
5. Insert the threaded stud slowly and with a slight twisting motion, until the required embedment depth is reached
6. Leave undisturbed until curing time of resin has elapsed
7. Attach fixture and tighten the nut to the required installation torque

All products listed in this publication are branded and distributed with RAWLPLUG® or RAWL® trademarks.

Product information

Hexagonal Head

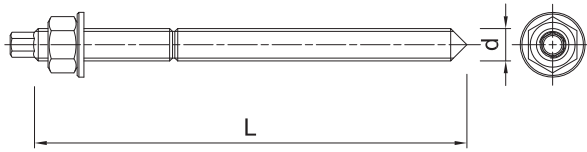

Flat Head

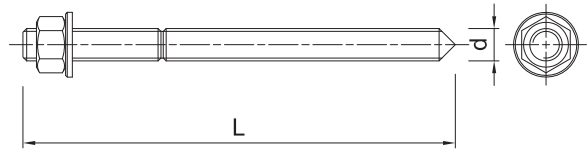

Size	Product Code	Anchor		Fixture			
		Diameter	Length	Max. thickness			Hole diameter
		d	L	t _{fix, min}	t _{fix, s}	t _{fix, max}	d _f
		[mm]	[mm]	[mm]	[mm]	[mm]	[mm]
R-STUDS Metric Threaded Rods - Steel Class 5.8							
M8	R-STUDS-08110 / R-STUDS-08110-FL	8	110	40	20	-	9
	R-STUDS-08160 / R-STUDS-08160-FL	8	160	90	70	50	9
M10	R-STUDS-10130 / R-STUDS-10130-FL	10	130	48	28	-	12
	R-STUDS-10170 / R-STUDS-10170-FL	10	170	88	68	38	12
M12	R-STUDS-12160 / R-STUDS-12160-FL	12	160	65	35	-	14
	R-STUDS-12190 / R-STUDS-12190-FL	12	190	95	65	30	14
	R-STUDS-12220 / R-STUDS-12220-FL	12	220	125	95	60	14
	R-STUDS-12260 / R-STUDS-12260-FL	12	260	165	135	100	14
M16	R-STUDS-16190 / R-STUDS-16190-FL	16	190	71	46	-	18
	R-STUDS-16220 / R-STUDS-16220-FL	16	220	101	76	11	18
	R-STUDS-16260 / R-STUDS-16260-FL	16	260	141	116	51	18
M20	R-STUDS-20260 / R-STUDS-20260-FL	20	260	117	67	-	22
	R-STUDS-20300 / R-STUDS-20300-FL	20	300	157	107	37	22
	R-STUDS-20350 / R-STUDS-20350-FL	20	350	207	157	87	22
M24	R-STUDS-24300 / R-STUDS-24300-FL	24	300	132	62	-	26
M30	R-STUDS-30380 / R-STUDS-30380-FL	30	380	181	106	-	32
R-STUDS Metric Threaded Rods - Steel Class 8.8							
M8	R-STUDS-08110-88 -	8	110	40	20	-	9
M10	R-STUDS-10130-88 -	10	130	48	28	-	12
M12	R-STUDS-12160-88 -	12	160	65	35	-	14
M16	R-STUDS-16190-88 -	16	190	71	46	-	18
	R-STUDS-16220-88 -	16	220	101	76	11	18
M20	R-STUDS-20260-88 -	20	260	117	67	-	22
M24	R-STUDS-24300-88 -	24	300	132	62	-	26
M30	R-STUDS-30380-88 -	30	380	181	76	-	32

Product information

Size	Product Code	Anchor		Fixture				
		Diameter	Length	Max. thickness t_{fix} for:			Hole diameter	Max. thickness
		d	L	$h_{nom, min}$	$h_{nom, std}$	$h_{nom, max}$	d_f	t_{fix}
		[mm]	[mm]	[mm]	[mm]	[mm]	[mm]	[mm]
R-STUDS Metric Threaded Rods - A4								
M8	R-STUDS-08110-A4 / R-STUDS-08110-A4FL	8	110	40	20	0	9	20
	R-STUDS-08160-A4	8	160	90	70	50	9	70
M10	R-STUDS-10130-A4 / R-STUDS-10130-A4FL	10	130	48	28	0	12	33
	R-STUDS-10170-A4 / R-STUDS-10170-A4FL	10	170	88	68	38	12	73
	R-STUDS-10190-A4 / R-STUDS-10190-A4FL	10	190	108	88	58	12	93
M12	R-STUDS-12160-A4 / R-STUDS-12160-A4FL	12	160	65	35	0	14	50
	R-STUDS-12190-A4 / R-STUDS-12190-A4FL	12	190	95	65	30	14	80
	R-STUDS-12220-A4	12	220	125	95	60	14	110
	R-STUDS-12260-A4	12	260	165	135	100	14	150
M16	R-STUDS-12300-A4	12	300	205	175	140	14	190
	R-STUDS-16190-A4 / R-STUDS-16190-A4FL	16	190	71	46	0	18	66
	R-STUDS-16220-A4 / R-STUDS-16220-A4FL	16	220	101	76	11	18	96
	R-STUDS-16260-A4 / R-STUDS-16260-A4FL	16	260	141	116	51	18	136
	R-STUDS-16300-A4	16	300	181	156	91	18	176
M20	R-STUDS-16380-A4	16	380	261	236	171	18	256
	R-STUDS-20260-A4 / R-STUDS-20260-A4FL	20	260	117	67	0	22	-
	R-STUDS-20300-A4	20	300	157	107	37	22	-
M24	R-STUDS-20350-A4	20	350	207	157	87	22	-
	R-STUDS-24300-A4 / R-STUDS-24300-A4FL	24	300	132	62	0	26	-
M30	R-STUDS-30380-A4 / R-STUDS-30380-A4FL	30	380	181	76	0	32	-

Product commercial data

Size	Product Code	Anchor		Quantity [pcs]			Weight [kg]			Bar Codes
		Diameter [mm]	Length [mm]	Box	Outer	Pallet	Box	Outer	Pallet	
R-STUDS Metric Threaded Rods - Steel Class 5.8										
M8	R-STUDS-08110	8	110	10	500	4200	0.43	21.6	211.4	5906675127477
	R-STUDS-08160	8	160	10	150	4200	0.61	9.1	284.1	5906675234649
M10	R-STUDS-10130	10	130	10	300	9000	0.77	23.1	723.9	5906675127484
	R-STUDS-10170	10	170	10	10	4200	1.01	1.01	453.4	5906675234663
	R-STUDS-10190	10	190	10	250	9000	1.09	27.4	1014.6	5906675234670
M12	R-STUDS-12160	12	160	10	120	5400	1.45	17.4	813.0	5906675127491
	R-STUDS-12190	12	190	10	120	5760	1.57	18.8	931.4	5906675234694
	R-STUDS-12220	12	220	10	120	5760	1.77	21.3	1051.2	5906675234700
	R-STUDS-12260	12	260	10	90	4200	2.1	19.0	914.9	5906675234717
M16	R-STUDS-12300	12	300	10	10	4500	2.4	2.4	1110.0	5906675234731
	R-STUDS-16190	16	190	10	60	3600	2.8	17.0	1049.2	5906675130903
	R-STUDS-16220	16	220	10	60	2880	3.3	19.7	975.8	5906675234748
	R-STUDS-16260	16	260	10	60	1920	3.8	22.8	760.9	5906675234755
	R-STUDS-16300	16	300	5	5	270	2.2	2.2	148.3	5906675234762
M20	R-STUDS-16380	16	380	1	40	1300	0.57	23.0	776.5	5906675234779
	R-STUDS-20260	20	260	5	40	1600	2.9	23.4	964.1	5906675234786
	R-STUDS-20300	20	300	5	5	870	3.5	3.5	632.4	5906675379463
M24	R-STUDS-20350	20	350	2	2	-	1.57	1.57	-	5906675324883
	R-STUDS-24300	24	300	2	12	1000	2.0	11.7	1004.0	5906675260433
M30	R-STUDS-30380	30	380	2	2	500	3.9	3.9	1011.5	5010445001611
R-STUDS Metric Threaded Rods - Steel Class 8.8										
M8	R-STUDS-08110-88	8	110	10	10	5040	0.42	0.42	241.7	5906675076171
M10	R-STUDS-10130-88	10	130	10	250	-	0.77	19.4	--	5906675076188
M12	R-STUDS-12160-88	12	160	10	120	-	1.33	15.9	-	5906675076195

All products listed in this publication are branded and distributed with RAWLPLUG® or RAWL® trademarks.

Product commercial data (cont.)

Size	Product Code	Anchor		Quantity [pcs]			Weight [kg]			Bar Codes
		Diameter [mm]	Length [mm]	Box	Outer	Pallet	Box	Outer	Pallet	
M16	R-STUDS-16190-88	16	190	10	60	-	2.8	17.0	-	5906675076201
	R-STUDS-16220-88	16	220	10	10	1990	3.2	3.2	666.8	5906675060514
M20	R-STUDS-20260-88	20	260	5	40	-	2.9	23.4	-	5906675076218
M24	R-STUDS-24300-88	24	300	2	2	-	2.0	2.0	-	5906675076225
M30	R-STUDS-30380-88	30	380	2	2	-	3.9	3.9	-	5906675076232
R-STUDS Metric Threaded Rods - Steel Class 5.8, Flat Head										
M8	R-STUDS-08110-FL	8	110	10	10	5040	0.43	0.43	245.7	5010445001468
	R-STUDS-08160-FL	8	160	10	10	2030	0.43	0.43	117.3	5906675260372
M10	R-STUDS-10130-FL	10	130	10	250	5040	0.77	19.3	419.6	5010445001482
	R-STUDS-10170-FL	10	170	10	10	3780	1.01	1.01	412.5	5906675260389
M12	R-STUDS-12160-FL	12	160	10	100	7200	1.35	13.5	1001.3	5010445001512
	R-STUDS-12190-FL	12	190	10	120	1000	1.56	18.7	186.1	5906675262338
	R-STUDS-12220-FL	12	220	10	120	3200	1.79	21.5	604.1	5906675261706
M16	R-STUDS-12260-FL	12	260	10	10	1100	2.1	2.1	259.7	5906675260396
	R-STUDS-16190-FL	16	190	10	60	3840	2.9	17.2	1127.5	5010445001550
	R-STUDS-16220-FL	16	220	10	10	1920	3.3	3.3	660.3	5906675260402
M20	R-STUDS-16260-FL	16	260	10	10	1920	3.8	3.8	759.6	5906675260419
	R-STUDS-20260-FL	20	260	6	36	1728	3.6	21.5	1062.5	5010445001598
	R-STUDS-20300-FL	20	300	5	30	270	3.4	20.6	215.4	5906675262468
M24	R-STUDS-20350-FL	20	350	10	10	960	8.1	8.1	802.8	5906675234793
	R-STUDS-24300-FL	24	300	2	2	770	2.0	2.0	779.2	5906675240794
M30	R-STUDS-30380-FL	30	380	1	1	500	1.94	1.94	999.0	5906675234816
R-STUDS Metric Threaded Rods - A4										
M8	R-STUDS-08110-A4	8	110	10	10	4200	0.43	0.43	210.2	5010445001642
	R-STUDS-08160-A4	8	160	10	10	-	6.0	6.0	-	5906675324920
M10	R-STUDS-10130-A4	10	130	10	10	900	0.79	0.79	101.5	5906675324823
	R-STUDS-10170-A4	10	170	10	10	-	10.1	10.1	-	5906675324937
	R-STUDS-10190-A4	10	190	10	10	-	1.10	1.10	-	5906675324944
M12	R-STUDS-12160-A4	12	160	10	120	5760	1.37	16.5	820.8	5906675234830
	R-STUDS-12190-A4	12	190	10	10	-	1.80	1.80	-	5906675324951
	R-STUDS-12220-A4	12	220	10	10	5760	1.77	1.77	1048.4	5906675089416
	R-STUDS-12260-A4	12	260	10	10	-	2.2	2.2	-	5906675324968
M16	R-STUDS-12300-A4	12	300	10	10	-	2.5	2.5	-	5906675324975
	R-STUDS-16190-A4	16	190	10	10	4200	2.9	2.9	1243.8	5906675234847
	R-STUDS-16220-A4	16	220	10	10	-	3.0	3.0	-	5906675324982
	R-STUDS-16260-A4	16	260	10	10	240	41.0	41.0	1014.0	5906675176420
	R-STUDS-16300-A4	16	300	10	10	-	4.5	4.5	-	5906675325002
M20	R-STUDS-16380-A4	16	380	10	10	-	5.5	5.5	-	5906675325019
	R-STUDS-20260-A4	20	260	5	5	1584	3.0	3.0	977.5	5906675234854
	R-STUDS-20300-A4	20	300	2	2	-	1.40	1.40	-	5906675324906
M24	R-STUDS-20350-A4	20	350	2	2	-	1.80	1.80	-	5906675324913
	R-STUDS-24300-A4	24	300	2	2	260	2.1	2.1	300.1	5906675176406
M30	R-STUDS-30380-A4	30	380	2	2	-	3.9	3.9	-	5906675176444
R-STUDS Metric Threaded Rods - A4, Flat Head										
	R-STUDS-08110-A4FL	8	110	10	10	4200	0.43	0.43	210.2	5906675260440
	R-STUDS-10130-A4FL	10	130	10	10	9600	0.80	0.80	799.9	5906675260457
	R-STUDS-10170-A4FL	10	170	10	10	530	1.02	1.02	83.8	5906675261409
	R-STUDS-12160-A4FL	12	160	10	120	1800	1.37	16.5	277.3	5010445001727
	R-STUDS-12190-A4FL	12	190	10	10	5760	1.62	1.62	962.5	5906675261393
	R-STUDS-16190-A4FL	16	190	10	10	960	2.9	2.9	309.3	5906675260471
	R-STUDS-16220-A4FL	16	220	10	10	1000	3.3	3.3	361.6	5906675267425
	R-STUDS-16260-A4FL	16	260	10	10	240	41.0	41.0	1014.0	5906675176468
	R-STUDS-20260-A4FL	20	260	5	5	1600	3.0	3.0	1002.2	5906675260488
	R-STUDS-24300-A4FL	24	300	2	2	770	2.1	2.1	841.2	5906675260495
R-STUDS-30380-A4FL	30	380	2	2	-	3.9	3.9	-	5906675176482	

R-ITS Internally Threaded Sockets

Internally threaded socket for the attachment of suitable bolt or threaded rod.

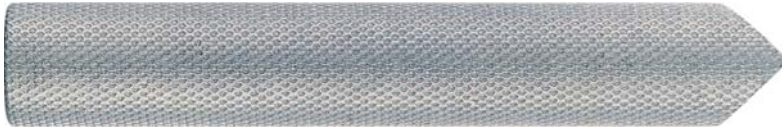

Product overview

Features and benefits

- Allows removal of bolt to leave a re-usable socket in place
- High load-bearing capacity
- Close edge and spacing distances
- Expansion free functioning
- Available in zinc plated and stainless steel versions

Applications

- For fastening of threaded rods or bolts
- Safety barriers
- Temporary works/formworks support systems

Base materials

- Approved for use in:
- Non-cracked concrete C20/25-C50/60

Installation guide

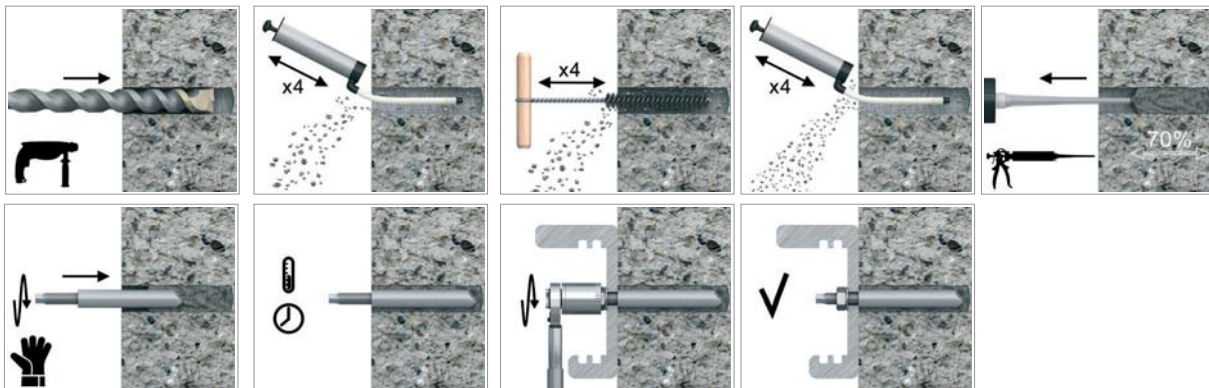

1. After injecting resin, immediately insert the socket anchor, slowly and with a slight twisting motion until flush with surface
2. Remove excess resin, then leave anchorage undisturbed until curing time has elapsed
3. After injecting resin, immediately insert the socket anchor, slowly and with a slight twisting motion until flush with surface
4. For installation with a drilling machine, insert the setting tool into socket and spin in using rotary hammer action
5. Remove excess resin, then leave anchorage undisturbed until curing time has elapsed

Product information

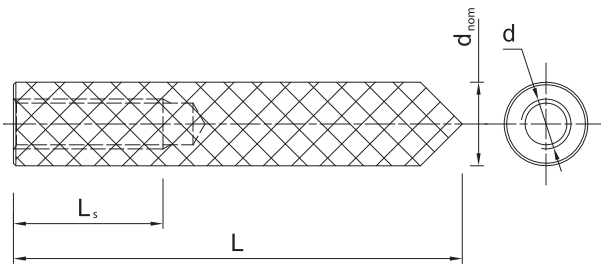

Size	Product Code	Anchor				Fixture
		Diameter	Diameter	Length	Internal thread length	Hole diameter
		d [mm]	d _{nom} [mm]	L [mm]	L _s [mm]	d _i [mm]
R-ITS-Z						
M6	R-ITS-Z-06075	6	10	75	24	7
M8	R-ITS-Z-08075	8	12	75	25	9
	R-ITS-Z-08090	8	12	90	25	9
M10	R-ITS-Z-10075	10	16	75	30	12
	R-ITS-Z-10100	10	16	100	30	12
M12	R-ITS-Z-12100	12	16	100	35	14
M16	R-ITS-Z-16125	16	24	125	50	18
R-ITS-A4						
M6	R-ITS-A4-06075	6	10	75	24	7
M8	R-ITS-A4-08075	8	12	75	25	9
	R-ITS-A4-08090	8	12	90	25	9
M10	R-ITS-A4-10075	10	16	75	30	12
	R-ITS-A4-10100	10	16	100	30	12
M12	R-ITS-A4-12100	12	16	100	35	14
M16	R-ITS-A4-16125	16	24	125	50	18

Product commercial data

	Product Code	Anchor		Quantity [pcs]			Weight [kg]			Bar Code
		Diameter	Length	Box	Outer	Pallet	Box	Outer	Pallet	
R-ITS-Z										
M6	R-ITS-Z-06075	11	75	10	10	5600	0.41	0.41	260.7	5010445606205
M8	R-ITS-Z-08075	12.5	75	10	10	5600	0.65	0.65	394.0	5906675087719
	R-ITS-Z-08090	12.5	90	10	10	5600	0.70	11.2	422.0	5010445606236
M10	R-ITS-Z-10075	16.5	75	10	10	5600	0.77	0.77	461.2	5010445606243
	R-ITS-Z-10100	16.5	100	10	10	3360	1.36	21.7	486.0	5010445606267
M12	R-ITS-Z-12100	18	100	6	6	2016	0.69	0.69	261.8	5906675087726
M16	R-ITS-Z-16125	22	125	6	6	2016	2.0	2.0	699.3	5906675087733
R-ITS-A4										
M6	R-ITS-A4-06075	11	75	10	10	3780	0.40	0.40	181.2	5906675087740
M8	R-ITS-A4-08075	12.5	75	10	10	7000	0.62	0.62	464.0	5906675087757
	R-ITS-A4-08090	12.5	90	10	10	3780	0.62	0.62	264.4	5906675087764
M10	R-ITS-A4-10075	16.5	75	10	10	3780	1.29	1.29	517.6	5010445609893
	R-ITS-A4-10100	16.5	100	10	10	4200	1.04	1.04	466.8	5010445609923
M12	R-ITS-A4-12100	18	100	6	6	2400	1.15	1.15	490.8	5010445609930
M16	R-ITS-A4-16125	22	125	6	6	2400	1.57	1.57	658.8	5906675087771

R-BRUSH



MANUAL AND AUTOMATIC WIRE BRUSHES

Ideal for cleaning dust from drilled holes prior to applying bonded anchors or installing mechanical anchors. Hole cleaning is necessary for correct loads. Suitable for variable anchor embedment depths. Suitable for repetitive and frequent use.



Durability and strength

Right quality of the brush ensures adequate cleaning of holes from debris and dust

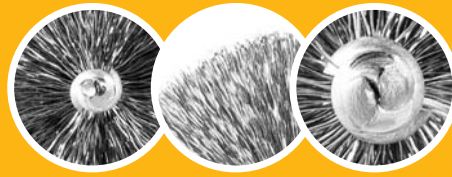

Select the right diameter of brushes. Do not use brushes which are too small. During cleaning, resistance must be encountered after insertion into the hole that has been drilled.

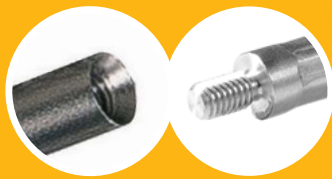

Brushes and extensions can be connected to the required depth of the hole

Extensions are made of stainless steel, which makes them rugged and suitable for long-term operation in tough conditions

Are appropriate for manual cleaning holes drilled in concrete and masonry



Can be operated automatically with an SDS PLUS

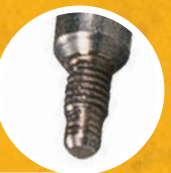

R-BRUSH Manual and automatic Wire Brushes

Brush accessory for cleaning out holes prior to anchor installation

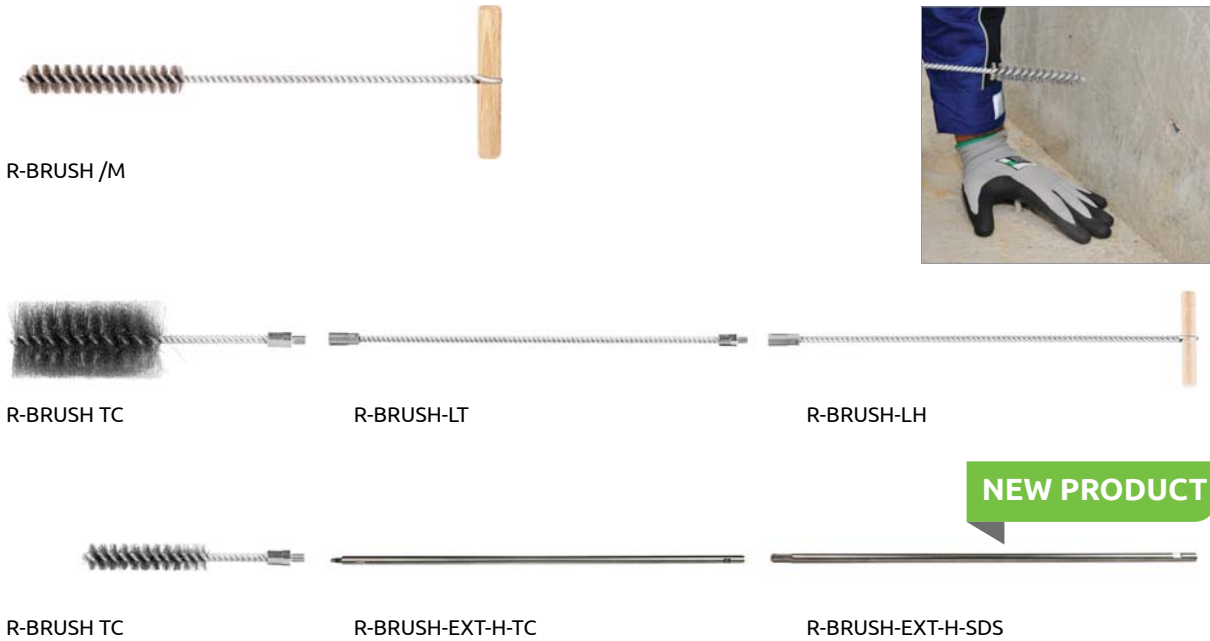

Features and benefits

- Ideal for cleaning dust from drilled holes prior to applying bonded anchors or installing mechanical anchors
- Hole cleaning is necessary for correct loads
- Suitable for variable anchor embedment depths.
- Suitable for repetitive and frequent use.

Installation guide for brushes and blow pump



1. Drill hole to the required diameter and depth for stud size being used.
2. Choose a brush for the diameter of the hole
3. Connect the brush with the correct extension for the hole depth
4. Connect the brush set to the hammer drill (automatic cleaning 2x2x2)
5. Clean the hole thoroughly with compressed air at least two times before installation
6. Insert the brush set into the hole and turn on the drill to reach the bottom of the hole 2 times.
7. Insert compressed air into the bottom of the hole and two times blow the hole until the air stream is free noticeable of dust.

All products listed in this publication are branded and distributed with RAWLPLUG® or RAWL® trademarks.

Product commercial data

Product Code	Drill diameter [mm]	Quantity [pcs]			Weight [kg]			Bar Code
		Box	Outer	Pallet	Box	Outer	Pallet	
Manual Wire Brushes								
R-BRUSH-M08/M	10	1	10	300	0.10	1.01	60.3	5906675249759
R-BRUSH-M10/M	12	1	10	500	0.10	1.01	80.6	5906675249766
R-BRUSH-M12/M	14	1	10	500	0.10	1.01	80.6	5906675249773
R-BRUSH-M16/M	18	1	10	400	0.10	1.01	70.5	5906675249780
R-BRUSH-M20/M	24	1	10	250	0.10	1.01	55.3	5906675249797
R-BRUSH-M24/M	28	1	10	250	0.10	1.01	55.3	5906675249803
R-BRUSH-M30/M	35	1	10	300	0.10	1.01	60.3	5906675249810
Manual Plastic Brushes								
R-BRUSH-M08/10	M8-M10	1	1	3600	0.03	0.03	127.2	5906675130897
R-BRUSH-M10/14	M12-M14	1	1	3600	0.03	0.03	127.2	5906675127446
R-BRUSH-M16/28	M16	1	1	3600	0.06	0.06	246.0	5906675127453
Wire brush with threaded coupling								
R-BRUSH-12-TC	12	1	1	-	0.05	0.05	-	5906675432656
R-BRUSH-14-TC	14	1	1	-	0.05	0.05	-	5906675432663
R-BRUSH-16-TC	16	1	1	-	0.06	0.06	-	5906675432670
R-BRUSH-18-TC	18	1	1	-	0.06	0.06	-	5906675432687
R-BRUSH-20-TC	20	1	1	-	0.07	0.07	-	5906675432694
R-BRUSH-22-TC	22	1	1	-	0.07	0.07	-	5906675432700
R-BRUSH-27-TC	27	1	1	-	0.10	0.10	-	5906675432717
R-BRUSH-32-TC	32	1	1	-	0.11	0.11	-	5906675432724
R-BRUSH-37-TC	37	1	1	-	0.13	0.13	-	5906675432731
R-BRUSH-42-TC	42	1	1	-	0.15	0.15	-	5906675432748
R-BRUSH-52-TC	52	1	1	-	0.15	0.15	-	5906675432755
Extension for R-BRUSH with threaded coupling								
R-BRUSH-EXT-LH	-	1	1	-	0.15	0.15	-	5906675432762
R-BRUSH-EXT-LT	-	1	1	-	0.15	0.15	-	5906675432779
Extension for machine cleaning R-BRUSH with threaded coupling								
R-BRUSH-EXT-H-TC		1	10	-	0.35	3.5		5906675436104
R-BRUSH-EXT-H-SDS		1	10		0.35	3.5		5906675436111

R-BLOWPUMP Blow Pump

Manual blow pump ideal for cleaning dust from drilled holes prior to applying bonded anchors or installing mechanical anchors



Features and benefits

- Ideal for cleaning dust from drilled holes prior to applying bonded anchors or installing mechanical anchors
- Hole cleaning is necessary for correct loads
- Manual, easy to use
- Serial application

Installation guide for brushes and blow pump

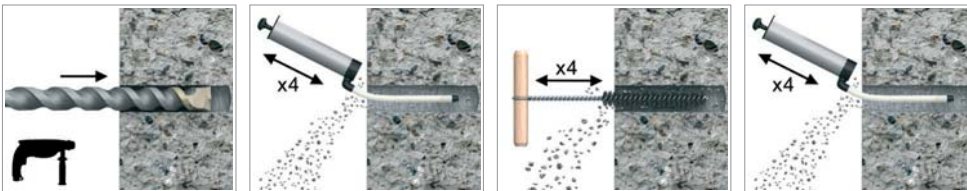

1. Before inserting anchor, clear debris from hole
2. Insert pipe to bottom of hole and pump air repeatedly four times
3. Additional use of hole brush is recommended, four times

Product commercial data

Product Code	Quantity [pcs]	Weight [kg]		Bar Code
		Box	Outer	
R-BLOWPUMP	1	12.0	12.0	5906675102412

RT-MAXH Hollow drill bits Dustlessdrill SDS max

Hollow drill bits SDS max for dust-free drilling in reinforced concrete



Certificate



Installation movie

Product information

Features and benefits

- Two holes in the tip of the drill bit allows you to drill and extract dust simultaneously (due to the possibility of fastening a vacuum cleaner)
- Drilling, along with dust extraction, make the hole smooth and clean
- Quick removal of dust increases drilling speed and enhances drill bit durability (reduces friction)
- Drilled holes do not require cleaning before fastening, which greatly reduces assembly time
- Rubber adapter, which is built-in the bit, enables you to fasten a vacuum cleaner hose and to drill holes without dust

Applications

- Drilling holes in reinforced concrete, concrete, stone and hard brick

Base materials

- Reinforced concrete
- Concrete
- Solid Brick
- Solid Concrete Block

Commercial product data

Index	Drill diameter	Length	Working length	Quantity	Weight	Outer weight	EAN
	[mm]	[mm]	[mm]	[pcs]	kg	kg	
RT-MAXH-14/600	14	600	400	1	0.82	4.11	5906675397085
RT-MAXH-16/600	16	600	400	1	0.92	4.59	5906675397092
RT-MAXH-18/600	18	600	400	1	0.99	4.97	5906675397108
RT-MAXH-20/600	20	600	400	1	1.13	5.64	5906675397115
RT-MAXH-22/600	22	600	400	1	1.13	5.64	5906675397122
RT-MAXH-25/600	25	600	400	1	1.12	5.62	5906675397139
RT-MAXH-28/600	28	600	400	1	1.29	6.44	5906675397146
RT-MAXH-30/600	30	600	400	1	1.44	7.18	5906675397153
RT-MAXH-32/600	32	600	400	1	1.48	7.40	5906675397160
RT-MAXH-35/600	35	600	400	1	1.59	7.93	5906675397177

RT-SDSH Hollow drill bits Dustlessdrill SDS plus

Hollow drill bits SDS plus for dust-free drilling in concrete

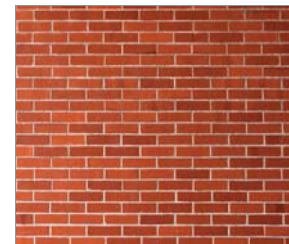

Certificate



Installation movie

Product information

Features and benefits

- Two holes in the tip of the drill bit allows you to drill and extract dust simultaneously (due to the possibility of fastening a vacuum cleaner)
- Drilling, along with dust extraction, make the hole smooth and clean
- Quick removal of dust increases drilling speed and enhances drill bit durability (reduces friction)
- Drilled holes do not require cleaning before fastening, which greatly reduces assembly time
- Centring point for quick commencement of drilling without the drill slipping
- Very deep seating of carbide plate significantly improves connection with the drill core, which affects quality

Applications

- Drilling holes in reinforced concrete, concrete, stone and hard brick

Base materials

- Concrete
- Solid Brick
- Solid Concrete Block
- Natural stone

Commercial product data

Index	Drill diameter	Length	Working length	Quantity	Weight	Outer weight	EAN
	[mm]	[mm]	[mm]	[pcs]	kg	kg	
RT-SDSH-8/270	8	270	150	1	0.22	1.10	5906675397184
RT-SDSH-10/270	10	270	150	1	0.25	1.25	5906675397191
RT-SDSH-12/320	12	320	200	1	0.31	1.56	5906675397207
RT-SDSH-14/370	14	370	250	1	0.39	1.95	5906675397214
RT-SDSH-15/370	15	370	250	1	0.50	2.48	5906675397221
RT-SDSH-16/370	16	370	250	1	0.43	2.17	5906675397238
RT-SDSH-18/370	18	370	250	1	0.53	2.63	5906675397245
RT-SDSH-20/370	20	370	250	1	0.62	3.11	5906675397252
RT-SDSH-24/370	24	370	250	1	0.01	0.05	5906675397269

All products listed in this publication are branded and distributed with RAWPLUG® or RAWL® trademarks.

Plastic and Wire Mesh Sleeves

Mesh sleeves for reduced mortar consumption and optimal mechanical interlock for masonry

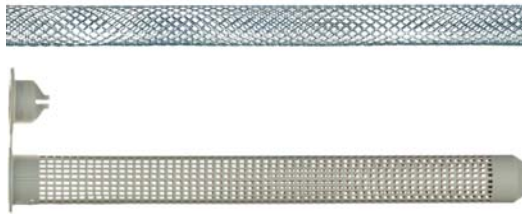

Product overview

Features and benefits

- Plastic version cap in ensures the anchor rod is properly centred
- Reduces consumption of resin
- User-friendly installation in hollow substrates
- Wire mesh must be cut to suit required hole depth
- Hole cleaning is not necessary

Applications

- For use with R-STUDS threaded rods in hollow base materials

Base materials

Approved for use in:

- Hollow Brick
- Hollow Lightweight Concrete Block
- Hollow Sand-lime Brick
- Hollow-core Slab

Installation guide

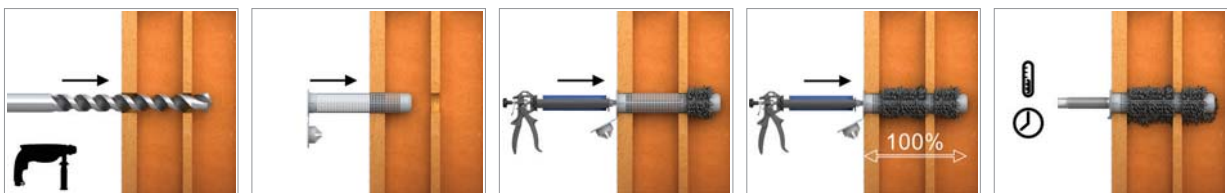

1. Simply insert the sleeve into pre-drilled hole before injection of the resin.

Product commercial data

Product Code	Size		Quantity [pcs]			Weight [kg]			Bar Code
	Sleeve [mm]	Stud	Box	Outer	Pallet	Box	Outer	Pallet	
R-PLS-12050-10	12x50	M8	10	480	8400	0.06	4.2	80.4	5906675377520
R-PLS-16085-10	16x85	M10-M12	10	6000	6000	0.05	2.5	60.0	5906675347547
R-PLS-16130-10	16x130	M10-M12	10	6000	4800	0.06	2.6	60.7	5906675347554
R-PLS-20085-10	20x85	M16	10	4800	4800	0.10	4.0	78.0	5906675291864
SP-CE-R08	10X1000	M8	10	10	5430	0.64	0.64	375.3	5906675266138
SP-CE-R10	12x1000	M10	10	10	1500	0.56	0.56	113.3	5906675610122
SP-CE-R12	16x1000	M12	10	10	1110	0.66	0.66	115.8	5906675610320
SP-CE-R16	22x1000	M16	10	10	384	1.29	1.29	79.5	5906675610528
SP-CE-R20	28x1000	M20	5	5	280	0.57	0.57	61.6	5906675610726

R-NOZ Mixer Nozzles

Static mixer for bonded anchors in cartridges and CFS+ system



R-NOZ



R-NOZ-KER-II



R-NOZ-KEX-II



Product overview

Features and benefits

- Convenient extrusion and mixing of resin and hardener
- Available with or without hanger
- Ideal for serial applications: rebar or anchoring
- R-NOZ fits R-KER, R-KEM II and R-KF2
- Specially dedicated nozzles for R-NOZ-KER II fits for hybride resin R-KER II resin, R-NOZ-KEX II fits R-KEX II epoxy resin
- Possibility of extension- attach R-NOZ-EXT - 1m extension nozzle

Applications

- For use in a wide range of fastening applications in concrete and solid masonry structures

Installation guide



1. Simply screw the mixer nozzle onto the resin cartridge (after removing cap) or CFS+ system
2. Before inserting nozzle to the hole inject resin until even colour is obtained
3. Insert mixing nozzle to the far end the hole and inject resin, slowly withdrawing the nozzle

Product commercial data

Product Code	Suitable for	Length [mm]	Quantity [pcs]		Weight [kg]		Bar Code
			Box	Outer	Box	Outer	
R-NOZ-10	R-KEM-II, R-KF2, R-KER	200	10	200	0.01	2.0	5906675127460
R-NOZ-100/100	R-KEM-II, R-KF2, R-KER	200	100	700	0.008	5.5	5010445606427
R-NOZ-KEX-II-10	R-KEX-II	250	10	100	0.2	2.0	5906675078373
R-NOZ-KEX-II-100	R-KEX-II	250	100	500	1.5	7.6	5906675078380
R-NOZ-KER-II-10	R-KER-II	215	10	200	0.10	2.0	5906675423593
R-NOZ-KER-II-100	R-KER-II	215	100	700	0.78	5.5	5906675423609

All products listed in this publication are branded and distributed with RAWLPLUG® or RAWL® trademarks.

Nozzle extension

Static mixer for bonded anchors in cartridges and CFS+ system



SP-CE-DE-1M



R-NOZ-EXT



Product overview

Features and benefits

- **SP-CE-DE-1M** Rigid extension pipe used or cleaning deep holes starting from the bottom of the hole
- **R-NOZ-EXT** An extension hose, making it possible to clean the hole uniformly, with no dust. To achieve this, the hose is connected to the compressor. Rawlplug offers extensions making it possible to clean over a length of up to 3 metres. It is important that the hoses can be conveniently cut to the required length.

Applications

- Ensure thorough cleaning of the hole, with removal of all drill dust, to make sure the appropriate load capacity is achieved
- Can be used in holes of different depths
- Are suitable for repeated and frequent use together with the brushes they form an approved cleaning system

Product commercial data

Product Code	Suitable for	Length [mm]	Quantity [pcs]		Weight [kg]		Bar Code
			Box	Outer	Box	Outer	
SP-CE-ED-1M	Extension for mixer nozzle	1000	10	10	0.02	0.02	5906675601120
R-NOZ-EXT-200	Extension for mixer nozzle	200	50	1000	0.20	4.0	5906675423357
R-NOZ-EXT-300	Extension for mixer nozzle	300	50	1000	0.30	6.0	5906675423517
R-NOZ-EXT-3000	Extension for mixer nozzle	3000	1	1	0.06	0.06	5906675430041

Dosing piston plug R-NOZ-P

Dosing piston plug



NEW PRODUCT

Product overview

Features and benefits

- Piston plug and flexible nozzle extension ensure correct, consistent injection of adhesive into the drilled hole free of air voids
- Allows anchoring in holes flooded with water and overhead applications
- Enables precise deep anchoring

Applications

- Full control over the degree to which the hole is filled with resin
- Uniform resin injection into the hole
- Absence of air bubbles in the hole
- Dispensing of the appropriate volume of the resin

Product commercial data

Product Code	Drill diameter	Quantity [pcs]		Weight [kg]		Bar Code
		Box	Outer	Box	Outer	
R-NOZ-P-16-26	16-26 mm	10	500			5906675433974
R-NOZ-P-28-50	28-50 mm	10	500			5906675433981

Installation guide for brushes and blow pump (cont.)



1. After hole cleaning dispense resin to waste until even colour is obtained (min. 10 cm)
2. Adjust (cut) the piston plug to the drilled diameter
3. Plug the piston plug into the extension and enter to the bottom of hole
4. The other end of the extension connects to the nozzle
5. Start injecting resin, piston plug will slide out of the hole (piston action)

R-GUN Dispenser Guns

Professional manual dispensing system for resin anchors in cartridges



R-GUN 385 ml



R-GUN 600 ml

Features and benefits

- Manual operation - no need for external power supply
- Type of gun used for anchoring strictly depends on the type of cartridge
- Fast and effortless resin injection
- Convenient dispensing tool for a range of situations
- Robust design for all jobsite conditions

Applications

- Dispenser guns suitable for 385ml, 600ml cartridges

Product commercial data

Product Code	Description	Quantity [pcs]		Weight [kg]		Bar Code
		Box	Outer	Box	Outer	
R-GUN-385-P	Cartridge Gun 385 ml for R-KEX II	1	150	1.7	255	5906675217482
R-GUN-600-P	Cartridge Gun 600 ml for R-KEX II	1	150	2.00	300	5906675314044



R-GUN MULTI

NEW PRODUCT

Features and benefits

- Perfect for professionals application
- Robust and durable design for all kinds of working conditions
- Quick and easy resin dispensing
- Manual operation - no need to use power supply
- One extrude for all kinds of cartridges
- Good leverage allows quick and easy resin dispensing
- Convenient to use
- Very high pressure power and injection comfort
- Release pressure system
- Reliable metal frame structure
- Durable design meets the high requirements for the construction site and thus offers a long service life

Applications

- Dispenser guns suitable for 175, 280, 300, 310, 380, 385, 400, 410, 600 ml cartridges

Product commercial data

Product Code	Description	Quantity [pcs]		Weight [kg]		Bar Code
		Box	Outer	Box	Outer	
R-GUN-MULTI	Manual dispensing system for cartridges: R-KEX-II-600, R-KEX-II-385 R-KER-II-400, R-KER-II-300, R-KER-380, R-KER-300, R-KEM-II-410, R-KEM-II-380, R-KEM-II-300, R-KEM-II-175	1	10	1.320	14	5906675418131

R-GUN Dispenser Guns

Professional manual dispensing system for bounded resin anchors in cartridges



R-GUN 300 N



R-GUN 345 N



R-GUN 380 P

Features and benefits

- Fast and effortless resin injection
- Convenient dispensing tool for a range of situations
- Type of gun used for anchoring strictly depends on the type of cartridge
- Robust design for all jobsite conditions

Applications

- Dispenser guns suitable for 175, 280, 300, 310, 345, 380-410ml cartridges

Installation guide



1. Open the cartridge and attach the proper nozzle.
2. Put the cartridge into the gun thoroughly.
3. Make sure that the nozzle is in correct position and lies in the fence.
4. By pressing the trigger dose the required amount of the product.
5. After finished work empty the gun and clean if necessary.

Product commercial data

Product Code	Suitable for	Description	Quantity [pcs]		Weight [kg]		Bar Code
			Box	Outer	Box	Outer	
R-GUN-300-N	R-KEM-II-300, R-KER-300, R-KER-II-300	Cartridge Gun 280, 300, 310 ml	12	12	12	12	5906675280141
R-GUN-345-N	R-KER-345, R-KER-II-345, R-KF2-345	Cartridge Gun 345 ml	12	12	12.0	12.0	5906675280158
R-GUN-380-P	R-KEM-II-380,410, R-KF2-380,400, R-KER-II-400, R-KER-380, R-KER-400	Cartridge Gun 380, 400, 410 ml	1	10	1.2	12.2	5906675280165

R-GUN Pneumatic Dispenser Guns

NEW

Professional pneumatic dispensing system for resin anchors in cartridges



R-GUN-PNEU 380 ml



R-GUN-PNEU 600 ml

Features and benefits

- Fast and effortless resin injection
- Convenient dispensing tool for a range of situations
- Robust design for all jobsite conditions
- Dispenser gun for professional use
- Professional dispensing system for resin anchors in cartridges
- Type of gun used for anchoring strictly depends on the type of cartridge

Applications

- Pneumatic dispenser gun suitable for: 380 ml and 600 ml cartridges

Product commercial data

Product Code	Description	Quantity [pcs]			Weight [kg]			Bar Code
		Box	Outer	Pallet	Box	Outer	Pallet	
R-GUN-380-PNEU	Cartridge Pneumatic Gun suitable for R-KF2, R-KER	1	1	584	1.30	1.30	789.2	5906675286068
R-GUN-KEX-600-PNEU	Cartridge Pneumatic Gun suitable for R-KEX-II 385ml, 600ml	1	1	150	2.40	2.40		5906675433097

R-GUN Electric Dispenser Gun for cartridges

Professional battery-powered cartridge bonded anchors dispenser gun



R-GUN 380 ml

Applications

- Battery-powered dispenser suitable for 380ml cartridges

Product commercial data

Product Code	Description	Quantity [pcs]		Weight [kg]		Bar Code
		Box	Outer	Box	Outer	
R-GUN-380-AKU	380ml Cartridges Electric Dispenser	1	50	2.2	110	5906675317250

R-GUN Battery Extrusion Gun with Dosing

Professional dispensing system for resin anchors in cartridges



R-GUN-380 ml-AKUDOSE

NEW PRODUCT



R-GUN-600 ml-AKUDOSE

Features and benefits

- Quick and easy application of resins
- Wireless work thanks to a powerful battery
- A unique option of memorizing the dose
- Smooth regulation of the dosing speed
- Anti-drip function
- Option of memorizing the dose
- Regulation of the dosing speed
- Battery powered - high performance lithium-ion battery
- Memory function - enables precise dispensing of a repetitive amount of resin

Applications

- Battery dispenser suitable for cartridges: 380ml, 385 ml, 400ml, 410ml, 600 ml
- Professional battery-powered guns, types:

R-GUN-380-AKUDOSE

intended for:
R-KEM-II 410ml,
R-KER 380ml, 400ml, R-KER-II
400ml, R-KF2 380ml, 400ml

R-GUN-KEX600-AKUDOSE

intended for:
R-KEX 385ml, R-KEX 600ml

Product commercial data

Product Code	Suitable for	Description	Quantity [pcs]		Weight [kg]		Bar Code
			Box	Outer	Box	Outer	
R-GUN-380-AKUDOSE	For 380-410ml (10:1 ratio) coaxial cartridges.	Battery squeezer for bonded anchors 380-410ml with adjustable dose	1	1	5.2	5.2	5906675322018
R-GUN-KEX600-AKUDOSE	For R-KEX II 385ml, R-KEX II 600 ml /coaxial cartridges.	Battery squeezer for bonded anchors 385-600ml with adjustable dose	1	1	8.2	8.2	5906675433080

All products listed in this publication are branded and distributed with RAWLPLUG® or RAWL® trademarks.

R-GUN Dispenser Gun CFS+

Professional dispensing system for resin anchors in CFS+ foils



R-CFS+-GUN 300 ml

Applications

- Dispenser gun suitable for: 300 ml CFS+ system



R-CFS+GUN 600 ml

Applications

- Dispenser gun suitable for: 600 ml CFS+ system

Features and benefits

- Fast and effortless resin injection
- Convenient dispensing tool for a range of situations
- Robust design for all jobsite conditions
- Dispenser gun for professional use
- Professional dispensing system for resin anchors in cartridges

Product commercial data

Product Code	Description	Quantity [pcs]			Weight [kg]			Bar Code
		Box	Outer	Pallet	Box	Outer	Pallet	
R-CFS+-GUN	300 ml Cartridge Gun For RV200, RMS0 & RP30	1	12	180	1.00	12.0	210.0	5906675239804
R-CFS+GUN-600	600 ml Cartridge Gun	1		150	0.8		120.0	5906675379289

R-GUN Electric Dispenser Gun CFS+

Professional electric dispensing gun for resin anchors in CFS+ foils



R-CFS+GUN 600 ml

Applications

- Battery-powered dispenser suitable for 600ml CFS+ foils

Product Code	Description	Quantity [pcs]		Weight [kg]		Bar Code
		Box	Outer	Box	Outer	
R-CFS+GUN-600-AKU	Electric Dispenser for 600ml cfs+ foils	1	100	2.0	200	5906675620022

Bonded Anchors



R-GUN-300-N



Suitable for:

R-KER 300ml
R-KER-II 300ml
R-KEM-II 175ml
R-KEM-II 300ml



R-GUN-345-N



Suitable for:

R-KER 345ml
R-KER-II 345ml
R-KF2 345ml



R-GUN-380-P



Suitable for:

R-KER 380ml, 400ml
R-KER-II 400ml
R-KEM-II 380ml, 410 ml
R-KF2 380ml, 400 ml



R-GUN-385-P



Suitable for:

R-KEX-II 385ml



R-GUN-600-P



Suitable for:

R-KEX-II 385ml, 600ml



R-GUN-MULTI



Suitable for:

R-KER 300ml, 380ml, 400ml
R-KER-II 300ml, 400ml
R-KEM-II 175ml, 300ml, 380ml, 410ml
R-KEX-II 385ml, 600ml



R-CFS+GUN-600
R-GUN-CFS+300-P



Suitable for:

R-CFS+ RV200 300ml, 600ml
R-CFS+ RM50 300ml, 600ml
R-CFS+ RP30 300ml, 600ml
R-CFS+ RV200 600ml
R-CFS+ RV200W 600ml



R-CFS+GUN-600-AKU



Suitable for:

R-CFS+RV200 600ml, 300ml
 R-CFS+RM50 600ml, 300ml
 R-CFS+RP30 600ml, 300ml



R-GUN-380-AKU



Suitable for:

R-KEM-II 410ml
 R-KF2 380ml, 400ml



R-GUN-380-AKUDOSE



Suitable for:

R-KEM-II 410ml
 R-KER 380ml, 400ml
 R-KER-II 400ml
 R-KF2 380ml, 400ml



R-GUN-600-AKUDOSE



Suitable for:

R-KEX II 385ml, 600ml



R-GUN-380-PNEU



Suitable for:

R-KEX II 385ml, 600ml

I[⊗]RAWLPLUG[®]
Trust & Innovation



Mechanical Anchors

The following pages provide detailed information and technical data for our range of Rawlplug® Mechanical Anchors.

These products have been designed to perform in demanding high-load and technical applications, but are equally suitable for your everyday anchoring requirements.

The range includes:
Throughbolts | Shield Anchors | Heavy-Duty Expansion Anchors
Wedge Anchors | Screw Anchors

THROUGHBOLTS

- R-HPTIIA4
 - Stainless Steel Throughbolt
- R-HPTIIZF
 - Zinc Flake Throughbolt
- R-XPTIIA4
 - Stainless Steel Throughbolt
- R-XPT
 - Throughbolt
- R-XPT-HD
 - Hot Dip Galvanized Throughbolt

Through fixing – drill and install directly through fixture

Head marking to determine anchor length /setting depth (post installation)

Embedment depth markings facilitate precise installation

Reduced embedment depth to avoid contact with reinforcement

Cold formed body ensures consistent dimensional accuracy

Optimised expander design with six grip features



R-HPTIIA4 Stainless Steel Throughbolt

Stainless steel throughbolt anchor for cracked and non-cracked concrete



Approvals and Reports

- ETA 17/0185



Installation movie

Product overview

Features and benefits

- Stainless steel material for the highest corrosion resistance
- High performance in cracked and non-cracked concrete confirmed by ETA Option 1
- Highest quality ensures maximum load capacity
- For applications requiring fire resistance up to 120 minutes
- Suitable for reduced embedment to avoid contact with reinforcement
- Embedment depth markings help to ensure precise installation of the anchor
- Design of R-HPTII allows drilling and installing directly through the fixture and helps to reduce installation time
- Suitable for installation in corrosive environments category C1, C2, C3 and C4
- Seismic category C1

Applications

- Cladding restraints
- Barriers
- Structural steel
- Curtain walling
- Hand rails
- Heavy plant
- Balustrading
- Passenger lifts
- Facades
- Fencing & gates
- Masonry support
- Platforms
- Public seating
- Racking systems

Base materials

Approved for use in:

- Cracked concrete C20/25-C50/60
- Non-cracked concrete C20/25-C50/60
- Unreinforced concrete C20/25-C50/60
- Reinforced concrete C20/25-C50/60

Also suitable for use in:

- Natural stone (after site testing)

Installation guide



1. Drill a hole of required diameter and depth
2. Clear the hole of drilling dust and debris (using blow pump and brush or equivalent method)
3. Lightly tap the throughbolt through the fixture into hole with a hammer, until fixing depth is reached
4. Tighten to the recommended torque

Product information

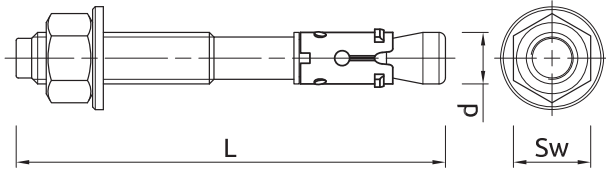

R-HPTII-A4 Stainless Steel Throughbolt with regular washer DIN 125A

Size	Product Code	Anchor		Fixture		
		Diameter	Length	Max. thickness t_{fix} for:		Hole diameter
		d	L	$h_{nom,red}$	$h_{nom,std}$	d_f
		[mm]	[mm]	[mm]	[mm]	[mm]
M8	R-HPTIIA4-08060/10	8	60	10	-	9
	R-HPTIIA4-08075/10	8	75	25	10	9
	R-HPTIIA4-08085/20	8	85	35	20	9
	R-HPTIIA4-08095/30	8	95	45	30	9
	R-HPTIIA4-08105/40	8	105	55	40	9
	R-HPTIIA4-08115/50	8	115	65	50	9
M10	R-HPTIIA4-10065/5	10	65	5	-	11
	R-HPTIIA4-10080/20	10	80	20	-	11
	R-HPTIIA4-10095/15	10	95	35	15	11
	R-HPTIIA4-10115/35	10	115	55	35	11
	R-HPTIIA4-10130/50	10	130	70	50	11
	R-HPTIIA4-10140/60	10	140	80	60	11
M12	R-HPTIIA4-12080/5	12	80	5	-	13
	R-HPTIIA4-12100/5	12	100	25	5	13
	R-HPTIIA4-12115/20	12	115	40	20	13
	R-HPTIIA4-12125/30	12	125	50	30	13
	R-HPTIIA4-12150/55	12	150	75	55	13
	R-HPTIIA4-12180/85	12	180	105	85	13
M16	R-HPTIIA4-16125/5	16	125	25	5	18
	R-HPTIIA4-16140/20	16	140	40	20	18
	R-HPTIIA4-16150/30	16	150	50	30	18
	R-HPTIIA4-16180/60	16	180	80	60	18

R-HPTII-A4 "D" Stainless Steel Throughbolt with large washer DIN 9021

Size	Product Code	Anchor		Fixture		
		Diameter	Length	Max. thickness t_{fix} for:		Hole diameter
		d	L	$h_{nom,red}$	$h_{nom,std}$	d_f
		[mm]	[mm]	[mm]	[mm]	[mm]
M8	R-HPTIIA4D08060/10	8	60	10	-	9
	R-HPTIIA4D08075/10	8	75	25	10	9
	R-HPTIIA4D08085/20	8	85	35	20	9
	R-HPTIIA4D08095/30	8	95	45	30	9
	R-HPTIIA4D08105/40	8	105	55	40	9
	R-HPTIIA4D08115/50	8	115	65	50	9
M10	R-HPTIIA4D10065/5	10	65	5	-	11
	R-HPTIIA4D10080/20	10	80	20	-	11
	R-HPTIIA4D10095/15	10	95	35	15	11
	R-HPTIIA4D10115/35	10	115	55	35	11
	R-HPTIIA4D10130/50	10	130	70	50	11
	R-HPTIIA4D10140/60	10	140	80	60	11
M12	R-HPTIIA4D12080/5	12	80	5	-	13
	R-HPTIIA4D12100/5	12	100	25	5	13
	R-HPTIIA4D12115/20	12	115	40	20	13
	R-HPTIIA4D12125/30	12	125	50	30	13
	R-HPTIIA4D12150/55	12	150	75	55	13
	R-HPTIIA4D12180/85	12	180	105	85	13

All products listed in this publication are branded and distributed with RAWLPLUG® or RAWL® trademarks.

Product information (cont.)

Size	Product Code	Anchor		Fixture		
		Diameter	Length	Max. thickness t_{fix} for:		Hole diameter
		d	L	$h_{nom,red}$	$h_{nom,std}$	d_f
		[mm]	[mm]	[mm]	[mm]	[mm]
M16	R-HPTIIA4D16125/5	16	125	25	5	18
	R-HPTIIA4D16140/20	16	140	40	20	18
	R-HPTIIA4D16150/30	16	150	50	30	18
	R-HPTIIA4D16180/60	16	180	80	60	18

Installation data

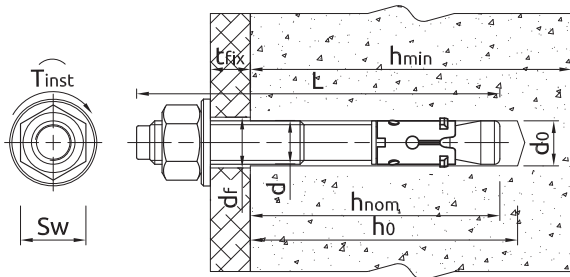

Size			M8	M10	M12	M16
Thread diameter	d	[mm]	8	10	12	16
Hole diameter in substrate	d_0	[mm]	8	10	12	16
Installation torque	T_{inst}	[Nm]	15	30	50	100
Wrench size	S_w	[mm]	13	17	19	24
STANDARD EMBEDMENT DEPTH						
Min. hole depth in substrate	$h_{0,s}$	[mm]	65	80	90	110
Installation depth	$h_{nom,s}$	[mm]	55	69	80	100
Min. substrate thickness	$h_{min,s}$	[mm]	100	120	140	170
Min. spacing (Non-cracked concrete)	$s_{min,s}$	[mm]	55	70	90	135
Min. spacing (Cracked concrete)	$s_{min,s}$	[mm]	55	70	90	135
Min. edge distance (Non-cracked concrete)	$c_{min,s}$	[mm]	40	50	55	80
Min. edge distance (Cracked concrete)	$c_{min,s}$	[mm]	40	45	55	70
REDUCED EMBEDMENT DEPTH						
Min. hole depth in substrate	$h_{0,r}$	[mm]	50	60	70	90
Installation depth	$h_{nom,r}$	[mm]	40	49	60	80
Min. substrate thickness	$h_{min,r}$	[mm]	100	100	100	130
Min. spacing (Non-cracked concrete)	$s_{min,r}$	[mm]	50	70	120	150
Min. spacing (Cracked concrete)	$s_{min,r}$	[mm]	50	70	120	150
Min. edge distance (Non-cracked concrete)	$c_{min,r}$	[mm]	50	60	70	90
Min. edge distance (Cracked concrete)	$c_{min,r}$	[mm]	40	50	70	85

Mechanical properties

Size			M8	M10	M12	M16
Nominal ultimate tensile strength - tension	F_{uk}	[N/mm ²]	600.0	600.0	550.0	550.0
Nominal yield strength - tension	F_{yk}	[N/mm ²]	450.0	150.0	413.0	413.0
Cross sectional area - tension	A_s	[mm ²]	36.6	58	84.3	157
Elastic section modulus	W_{el}	[mm ³]	50.27	98.17	169.65	402.12
Characteristic bending resistance	$M_{Rk,s}$	[Nm]	22.0	45.0	72.0	180.0
Design bending resistance	M	[Nm]	18	36	57	144.0

Basic performance data

Performance data for single anchor without influence of edge distance and spacing

Size		M8	M10	M12	M16
NON-CRACKED CONCRETE					
Standard embedment depth h_{ef}	[mm]	47.00	59.00	68.00	85.00
Reduced embedment depth h_{ef}	[mm]	32.00	39.00	48.00	65.00
CRACKED CONCRETE					
Standard embedment depth h_{ef}	[mm]	47.00	59.00	68.00	85.00
Reduced embedment depth h_{ef}	[mm]	32.00	39.00	48.00	65.00
CHARACTERISTIC LOAD					
TENSION LOAD N_{Rk}					
NON-CRACKED CONCRETE					
Standard embedment depth	[kN]	9.00	16.00	25.00	39.50
Reduced embedment depth	[kN]	7.50	12.00	16.80	26.40
CRACKED CONCRETE					
Standard embedment depth	[kN]	6.00	9.00	12.00	25.00
Reduced embedment depth	[kN]	3.00	7.50	9.00	16.00
SHEAR LOAD V_{Rk}					
NON-CRACKED CONCRETE					
Standard embedment depth	[kN]	11.70	18.50	24.60	45.40
Reduced embedment depth	[kN]	9.14	14.70	16.79	45.40
CRACKED CONCRETE					
Standard embedment depth	[kN]	11.60	16.31	24.60	45.40
Reduced embedment depth	[kN]	6.52	10.52	11.97	37.70
DESIGN LOAD					
TENSION LOAD N_{Rd}					
NON-CRACKED CONCRETE					
Standard embedment depth	[kN]	5.00	10.70	16.70	26.30
Reduced embedment depth	[kN]	4.17	6.67	11.20	17.60
CRACKED CONCRETE					
Standard embedment depth	[kN]	3.33	6.00	8.00	16.70
Reduced embedment depth	[kN]	1.67	4.17	6.00	10.70
SHEAR LOAD V_{Rd}					
NON-CRACKED CONCRETE					
Standard embedment depth	[kN]	9.40	14.80	19.70	36.30
Reduced embedment depth	[kN]	6.09	9.84	11.20	35.30
CRACKED CONCRETE					
Standard embedment depth	[kN]	7.73	10.88	19.68	36.30
Reduced embedment depth	[kN]	4.34	7.01	7.98	25.15
RECOMMENDED LOAD					
TENSION LOAD N_{rec}					
NON-CRACKED CONCRETE					
Standard embedment depth	[kN]	3.57	7.62	11.90	18.80
Reduced embedment depth	[kN]	2.98	4.76	8.00	12.60
CRACKED CONCRETE					
Standard embedment depth	[kN]	2.38	4.29	5.71	11.90
Reduced embedment depth	[kN]	1.19	2.98	4.29	7.62
SHEAR LOAD V_{rec}					
NON-CRACKED CONCRETE					
Standard embedment depth	[kN]	6.69	10.60	14.10	25.90
Reduced embedment depth	[kN]	4.35	7.03	8.00	25.20
CRACKED CONCRETE					
Standard embedment depth	[kN]	5.52	7.77	14.06	25.90
Reduced embedment depth	[kN]	3.10	5.01	5.70	18.00

Product commercial data

R-HPTII-A4 Stainless Steel Throughbolt with regular washer DIN 125A

Size	Product Code	Anchor		Quantity [pcs]			Weight [kg]			Bar Code
		Diameter [mm]	Length [mm]	Box	Outer	Pallet	Box	Outer	Pallet	
M8	R-HPTIIA4-08060/10	8	60	100	100	16000	2.6	2.6	441.0	5906675408873
	R-HPTIIA4-08075/10	8	75	100	100	12000	3.1	3.1	397.2	5906675408880
	R-HPTIIA4-08085/20	8	85	100	100	12000	3.3	3.3	430.2	5906675408897
	R-HPTIIA4-08095/30	8	95	100	100	12000	3.3	3.3	426.0	5906675408903
	R-HPTIIA4-08105/40	8	105	50	50	12000	2.2	2.2	558.0	5906675408910
	R-HPTIIA4-08115/50	8	115	100	100	12000	4.3	4.3	545.3	5906675408934
M10	R-HPTIIA4-10065/5	10	65	50	50	11000	2.4	2.4	551.2	5906675408941
	R-HPTIIA4-10080/20	10	80	50	50	6000	2.8	2.8	359.8	5906675408958
	R-HPTIIA4-10095/15	10	95	50	50	6000	3.1	3.1	404.8	5906675408965
	R-HPTIIA4-10115/35	10	115	50	50	6000	3.7	3.7	468.1	5906675408972
	R-HPTIIA4-10130/50	10	130	50	50	6000	4.0	4.0	508.3	5906675408989
	R-HPTIIA4-10140/60	10	140	50	50	6000	4.2	4.2	537.7	5906675408996
M12	R-HPTIIA4-12080/5	12	80	50	50	6000	4.1	4.1	524.0	5906675409009
	R-HPTIIA4-12100/5	12	100	50	50	6000	4.8	4.8	605.5	5906675409016
	R-HPTIIA4-12115/20	12	115	50	50	6000	7.0	7.0	870.0	5906675409030
	R-HPTIIA4-12125/30	12	125	50	50	6000	5.8	5.8	721.9	5906675409047
	R-HPTIIA4-12150/55	12	150	50	50	4000	6.7	6.7	561.6	5906675409054
	R-HPTIIA4-12180/85	12	180	50	50	3000	7.8	7.8	496.0	5906675409061
M16	R-HPTIIA4-16125/5	16	125	25	25	3000	5.4	5.4	673.7	5906675409078
	R-HPTIIA4-16140/20	16	140	25	25	2000	5.8	5.8	493.7	5906675409085
	R-HPTIIA4-16150/30	16	150	25	25	2000	6.1	6.1	518.2	5906675409092
	R-HPTIIA4-16180/60	16	180	25	25	2000	7.2	7.2	602.5	5906675409108

R-HPTII-A4 "D" Stainless Steel Throughbolt with large washer DIN 9021

Size	Product Code	Anchor		Quantity [pcs]			Weight [kg]			Bar Code
		Diameter [mm]	Length [mm]	Box	Outer	Pallet	Box	Outer	Pallet	
M8	R-HPTIIA4D08060/10 ¹⁾	8	60	100	100	21000	2.6	2.6	569.5	5906675046419
	R-HPTIIA4D08075/10 ¹⁾	8	75	100	100	16000	3.1	3.1	519.6	5906675046426
	R-HPTIIA4D08085/20 ¹⁾	8	85	100	100	16000	3.3	3.3	563.6	5906675046433
	R-HPTIIA4D08095/30 ¹⁾	8	95	100	100	12000	3.3	3.3	426.0	5906675046440
	R-HPTIIA4D08105/40 ¹⁾	8	105	50	50	16000	2.2	2.2	734.0	5906675046457
	R-HPTIIA4D08115/50 ¹⁾	8	115	100	100	16000	4.3	4.3	717.0	5906675046464
M10	R-HPTIIA4D10065/5 ¹⁾	10	65	50	50	8000	2.4	2.4	409.0	5906675046471
	R-HPTIIA4D10080/20 ¹⁾	10	80	50	50	8000	2.8	2.8	469.7	5906675046488
	R-HPTIIA4D10095/15 ¹⁾	10	95	50	50	8000	3.1	3.1	529.7	5906675046495
	R-HPTIIA4D10115/35 ¹⁾	10	115	50	50	6000	3.7	3.7	468.1	5906675046501
	R-HPTIIA4D10130/50 ¹⁾	10	130	50	50	6000	4.0	4.0	508.3	5906675046518
	R-HPTIIA4D10140/60 ¹⁾	10	140	50	50	8000	4.2	4.2	707.0	5906675046532
M12	R-HPTIIA4D12080/5 ¹⁾	12	80	50	50	8000	4.1	4.1	688.7	5906675046549
	R-HPTIIA4D12100/5 ¹⁾	12	100	50	50	8000	4.8	4.8	797.4	5906675046556
	R-HPTIIA4D12115/20 ¹⁾	12	115	50	50	6000	7.0	7.0	870.0	5906675388106
	R-HPTIIA4D12125/30 ¹⁾	12	125	50	50	6000	5.8	5.8	721.9	5906675046563
	R-HPTIIA4D12150/55 ¹⁾	12	150	50	50	4000	6.7	6.7	561.6	5906675046570
	R-HPTIIA4D12180/85 ¹⁾	12	180	50	50	4000	7.8	7.8	651.3	5906675046587
M16	R-HPTIIA4D16125/5 ¹⁾	16	125	25	25	4000	5.4	5.4	888.2	5906675046594
	R-HPTIIA4D16140/20 ¹⁾	16	140	25	25	4000	5.8	5.8	957.4	5906675034898
	R-HPTIIA4D16150/30 ¹⁾	16	150	25	25	4000	6.1	6.1	1006.5	5906675046600
	R-HPTIIA4D16180/60 ¹⁾	16	180	25	25	3000	7.2	7.2	888.7	5906675046617

1) ETA 17/0185

R-HPTIIF Zinc Flake Throughbolt

Throughbolt anchor with corrosion-resistant coating for cracked and non-cracked concrete



Approvals and Reports

• ETA 17/0184



Installation movie

Product overview

Features and benefits

- New generation of throughbolt with unique corrosion-resistant coating
- High performance in cracked and non-cracked concrete confirmed by ETA Option 1
- Highest quality to receive optimal load capability
- For applications requiring fire resistance up to 120 minutes
- Suitable for reduced embedment to avoid contact with reinforcement
- Embedment depth markings help to ensure precise installation of the anchor
- Design of R-HPTIIF allows drilling and installing directly through the fixture and helps to reduce installation time
- Seismic category C1, C2

Applications

- Cladding restraints
- Consoles
- Barriers
- Structural steel
- Curtain walling
- Hand rails
- Heavy Plant
- Balustrading
- Passenger lifts
- Facades

Base materials

Approved for use in:

- Cracked concrete C20/25-C50/60
- Non-cracked concrete C20/25-C50/60
- Unreinforced concrete C20/25-C50/60
- Reinforced concrete C20/25-C50/60

Also suitable for use in:

- Natural stone (after site testing)

Installation guide



1. Drill a hole of required diameter and depth
2. Clear the hole of drilling dust and debris (using blow pump and brush or equivalent method)
3. Lightly tap the throughbolt through the fixture into hole with a hammer, until fixing depth is reached
4. Tighten to the recommended torque

All products listed in this publication are branded and distributed with RAWLPLUG® or RAWL® trademarks.

Product information

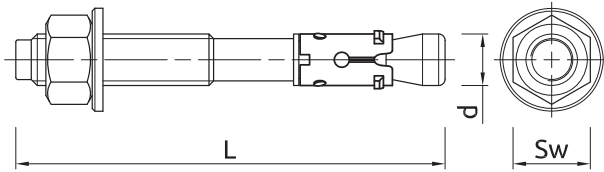

R-HPTII-ZF Zinc Flake Throughbolt with regular washer DIN 125A

Size	Product Code	Anchor		Fixture		
		Diameter	Length	Max. thickness t_{fix} for:		Hole diameter
		d	L	$h_{nom,red}$	$h_{nom,std}$	d_f
		[mm]	[mm]	[mm]	[mm]	[mm]
M8	R-HPTIIZF-08065/15	8	65	15	-	9
	R-HPTIIZF-08080/15	8	80	30	15	9
	R-HPTIIZF-08100/35	8	100	50	35	9
	R-HPTIIZF-08115/50	8	115	65	50	9
M10	R-HPTIIZF-10065/5	10	65	5	-	11
	R-HPTIIZF-10080/20	10	80	20	-	11
	R-HPTIIZF-10095/15	10	95	35	15	11
	R-HPTIIZF-10115/35	10	115	55	35	11
M12	R-HPTIIZF-10130/50	10	130	70	50	11
	R-HPTIIZF-12080/5	12	80	5	-	13
	R-HPTIIZF-12100/5	12	100	25	5	13
	R-HPTIIZF-12120/25	12	120	45	25	13
M16	R-HPTIIZF-12135/40	12	135	60	40	13
	R-HPTIIZF-12150/55	12	150	75	55	13
	R-HPTIIZF-16105/10	16	105	10	-	18
	R-HPTIIZF-16140/20	16	140	40	20	18
M20	R-HPTIIZF-16180/60	16	180	80	60	18
	R-HPTIIZF16220/100	16	220	120	100	18
	R-HPTIIZF-20125/5	20	125	5	-	22
	R-HPTIIZF-20160/20	20	160	40	20	22
	R-HPTIIZF-20200/60	20	200	80	60	22

R-HPTII-ZF „D“ Zinc Flake Throughbolt with large washer DIN 9021

Size	Product Code	Anchor		Fixture		
		Diameter	Length	Max. thickness t_{fix} for:		Hole diameter
		d	L	$h_{nom,red}$	$h_{nom,std}$	d_f
		[mm]	[mm]	[mm]	[mm]	[mm]
M8	R-HPTIIZFD08065/15	8	65	15	-	9
	R-HPTIIZFD08080/15	8	80	30	15	9
	R-HPTIIZFD08100/35	8	100	50	35	9
	R-HPTIIZFD08115/50	8	115	65	50	9
M10	R-HPTIIZFD10065/5	10	65	5	-	11
	R-HPTIIZFD10080/20	10	80	20	-	11
	R-HPTIIZFD10095/15	10	95	35	15	11
	R-HPTIIZFD10115/35	10	115	55	35	11
M12	R-HPTIIZFD10130/50	10	130	70	50	11
	R-HPTIIZFD12080/5	12	80	5	-	13
	R-HPTIIZD12100/5	12	100	25	5	13
	R-HPTIIZFD12120/25	12	120	45	25	13
M16	R-HPTIIZFD12135/40	12	135	60	40	13
	R-HPTIIZFD12150/55	12	150	75	55	13
	R-HPTIIZFD16105/10	16	105	10	-	18
	R-HPTIIZFD16140/20	16	140	40	20	18
M20	R-HPTIIZFD16180/60	16	180	80	60	18
	R-HPTIIZFD20125/5	20	125	5	-	22
	R-HPTIIZFD20160/20	20	160	40	20	22

Installation data

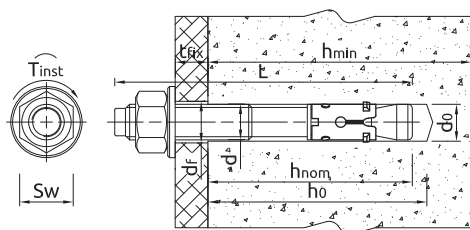

Size			M8	M10	M12	M16	M20
Thread diameter	d	[mm]	8	10	12	16	20
Hole diameter in substrate	d ₀	[mm]	8	10	12	16	20
Installation torque	T _{inst}	[Nm]	10	20	40	100	180
Wrench size	Sw	[mm]	13	17	19	24	30
STANDARD EMBEDMENT DEPTH							
Min. hole depth in substrate	h _{0,s}	[mm]	65	79	90	110	129
Installation depth	h _{nom,s}	[mm]	55	69	80	100	119
Min. substrate thickness	h _{min,s}	[mm]	100	120	140	170	200
Min. spacing (Non-cracked concrete)	s _{min,s}	[mm]	50	70	90	180	180
Min. spacing (Cracked concrete)	s _{min,s}	[mm]	50	70	90	180	180
Min. edge distance (Non-cracked concrete)	c _{min,s}	[mm]	40	50	65	100	120
Min. edge distance (Cracked concrete)	c _{min,s}	[mm]	40	45	65	100	100
REDUCED EMBEDMENT DEPTH							
Min. hole depth in substrate	h _{0,r}	[mm]	50	59	70	90	110
Installation depth	h _{nom,r}	[mm]	40	49	60	80	100
Min. substrate thickness	h _{min,r}	[mm]	100	100	100	130	160
Min. spacing (Non-cracked concrete)	s _{min,r}	[mm]	55	75	150	300	300
Min. spacing (Cracked concrete)	s _{min,r}	[mm]	55	75	150	300	300
Min. edge distance (Non-cracked concrete)	c _{min,r}	[mm]	45	60	70	160	200
Min. edge distance (Cracked concrete)	c _{min,r}	[mm]	40	50	80	120	120

Mechanical properties

Size			M8	M10	M12	M16	M20
Nominal ultimate tensile strength - tension	f _{uk}	[N/mm ²]	620	620	620	620	620
Nominal ultimate tensile strength - shear	f _{uk}	[N/mm ²]	520	520	520	520	520
Nominal yield strength - tension	f _{yk}	[N/mm ²]	531	531	531	531	531
Nominal yield strength - shear	f _{yk}	[N/mm ²]	416	416	416	416	416
Cross sectional area - tension	A _s	[mm ²]	25.5	40.7	60.1	106.6	162.9
Cross sectional area - shear	A _s	[mm ²]	38.9	61.7	89.6	165.2	259.1
Elastic section modulus	W _{el}	[mm ³]	34.3	68.3	119.6	299.5	588.3
Characteristic bending resistance	M ⁰ _{Rk,s}	[Nm]	19	38	67	167	328
Design bending resistance	M	[Nm]	15	31	53	134	263

Basic performance data

Performance data for single anchor without influence of edge distance and spacing

Size		M8	M10	M12	M16	M20
CRACKED CONCRETE						
Standard embedment depth h _{ef}	[mm]	47.00	59.00	68.00	85.00	99.00
Reduced embedment depth h _{ef}	[mm]	32.00	39.00	48.00	65.00	80.00
NON-CRACKED CONCRETE						
Standard embedment depth h _{ef}	[mm]	47.00	59.00	68.00	85.00	99.00
Reduced embedment depth h _{ef}	[mm]	32.00	39.00	48.00	65.00	80.00

Basic performance data (cont.)

Performance data for single anchor without influence of edge distance and spacing

Size		M8	M10	M12	M16	M20
CHARACTERISTIC LOAD						
TENSION LOAD N_{rk}						
NON-CRACKED CONCRETE						
Standard embedment depth	[kN]	9.00	12.00	20.00	35.00	49.74
Reduced embedment depth	[kN]	7.50	9.00	12.00	26.46	36.13
CRACKED CONCRETE						
Standard embedment depth	[kN]	5.00	9.00	12.00	20.00	30.00
Reduced embedment depth	[kN]	3.00	6.00	9.00	16.00	25.76
SHEAR LOAD V_{rk}						
NON-CRACKED CONCRETE						
Standard embedment depth	[kN]	9.10	15.70	23.70	47.10	60.60
Reduced embedment depth	[kN]	9.10	12.30	16.79	47.10	60.60
CRACKED CONCRETE						
Standard embedment depth	[kN]	9.10	15.70	23.70	47.10	60.60
Reduced embedment depth	[kN]	6.52	8.77	11.97	37.73	51.52
DESIGN LOAD						
TENSION LOAD N_{rd}						
NON-CRACKED CONCRETE						
Standard embedment depth	[kN]	5.00	8.00	13.30	23.33	33.16
Reduced embedment depth	[kN]	4.17	5.00	8.00	17.64	24.09
CRACKED CONCRETE						
Standard embedment depth	[kN]	2.78	6.00	8.00	13.33	20.00
Reduced embedment depth	[kN]	1.67	3.33	6.00	10.67	17.17
SHEAR LOAD V_{rd}						
NON-CRACKED CONCRETE						
Standard embedment depth	[kN]	7.28	12.56	18.96	37.68	48.48
Reduced embedment depth	[kN]	6.09	8.20	11.20	35.29	48.18
CRACKED CONCRETE						
Standard embedment depth	[kN]	7.28	10.88	18.96	37.62	47.28
Reduced embedment depth	[kN]	4.34	5.85	7.98	25.15	34.35
RECOMMENDED LOAD						
TENSION LOAD N_{rec}						
NON-CRACKED CONCRETE						
Standard embedment depth	[kN]	3.57	5.71	9.52	16.67	23.69
Reduced embedment depth	[kN]	2.98	3.57	5.71	12.60	17.21
CRACKED CONCRETE						
Standard embedment depth	[kN]	1.98	4.29	5.71	9.52	14.29
Reduced embedment depth	[kN]	1.19	2.38	4.29	7.62	12.27
SHEAR LOAD V_{rec}						
NON-CRACKED CONCRETE						
Standard embedment depth	[kN]	5.20	8.97	13.54	26.91	34.63
Reduced embedment depth	[kN]	4.35	5.86	8.00	25.20	34.41
CRACKED CONCRETE						
Standard embedment depth	[kN]	5.20	7.77	13.54	26.87	33.77
Reduced embedment depth	[kN]	3.10	4.18	5.70	17.97	24.53

Product commercial data

R-HPTII-ZF Zinc Flake Throughbolt with regular washer DIN 125A

Size	Product Code	Anchor		Quantity [pcs]			Weight [kg]			Bar Code
		Diameter [mm]	Length [mm]	Box	Outer	Pallet	Box	Outer	Pallet	
M8	R-HPTIIZF-08065/15	8	65	100	100	16000	2.8	2.8	474.6	5906675022840
	R-HPTIIZF-08080/15	8	80	100	100	16000	3.2	3.2	544.7	5906675022857
	R-HPTIIZF-08100/35	8	100	100	100	12000	3.9	3.9	494.3	5906675034881
	R-HPTIIZF-08115/50	8	115	100	100	16000	4.3	4.3	711.8	5906675022871
M10	R-HPTIIZF-10065/5	10	65	50	50	8000	2.4	2.4	409.4	5906675022888
	R-HPTIIZF-10080/20	10	80	50	50	8000	2.8	2.8	471.1	5906675022895
	R-HPTIIZF-10095/15	10	95	50	50	8000	3.1	3.1	528.2	5906675022901
	R-HPTIIZF-10115/35	10	115	50	50	6000	3.6	3.6	463.3	5906675022918
	R-HPTIIZF-10130/50	10	130	50	50	6000	4.0	4.0	682.0	5906675022925
M12	R-HPTIIZF-12080/5	12	80	50	50	8000	5.0	5.0	630.0	5906675022932
	R-HPTIIZF-12100/5	12	100	50	50	8000	4.8	4.8	794.3	5906675022949
	R-HPTIIZF-12120/25	12	120	50	50	6000	5.4	5.4	679.8	5906675022956
	R-HPTIIZF-12135/40	12	135	50	50	6000	6.1	6.1	758.9	5906675022963
	R-HPTIIZF-12150/55	12	150	50	50	4000	6.6	6.6	557.2	5906675022970
M16	R-HPTIIZF-16105/10	16	105	25	25	4000	4.6	4.6	765.7	5906675022987
	R-HPTIIZF-16140/20	16	140	25	25	4000	5.7	5.7	941.2	5906675022994
	R-HPTIIZF-16180/60	16	180	25	25	3000	7.1	7.1	883.3	5906675023007
	R-HPTIIZF16220/100	16	220	25	25	3000	8.4	8.4	1041.5	5906675023014
M20	R-HPTIIZF-20125/5	20	125	25	25	3000	8.2	8.2	639.9	5906675023021
	R-HPTIIZF-20160/20	20	160	25	25	3000	10.1	10.1	790.0	5906675023038
	R-HPTIIZF-20200/60	20	200	10	10	3000	4.9	4.9	400.0	5906675023045

R-HPTII-ZF „D“ Zinc Flake Throughbolt with large washer DIN 9021

Size	Product Code	Anchor		Quantity [pcs]			Weight [kg]			Bar Codes
		Diameter [mm]	Length [mm]	Box	Outer	Pallet	Box	Outer	Pallet	
M8	R-HPTIIZFD08065/15 ¹⁾	8	65	100	100	12000	3.9	3.9	494.3	5906675403175
	R-HPTIIZFD08080/15 ¹⁾	8	80	100	100	12000	3.2	3.2	416.0	5906675402505
	R-HPTIIZFD08100/35 ¹⁾	8	100	100	100	17000	5.0	5.0	873.0	5906675403199
	R-HPTIIZFD08115/50 ¹⁾	8	115	100	100	12000	5.4	5.4	672.1	5906675403205
M10	R-HPTIIZFD10065/5 ¹⁾	10	65	50	50	10500	2.9	2.9	643.4	5906675403212
	R-HPTIIZFD10080/20 ¹⁾	10	80	50	50	6000	3.3	3.3	426.8	5906675403236
	R-HPTIIZFD10095/15 ¹⁾	10	95	50	50	6000	3.7	3.7	469.7	5906675403243
	R-HPTIIZFD10115/35 ¹⁾	10	115	50	50	6000	4.2	4.2	529.3	5906675403250
	R-HPTIIZFD10130/50 ¹⁾	10	130	50	50	6000	4.6	4.6	576.1	5906675403267
M12	R-HPTIIZFD12080/5 ¹⁾	12	80	50	50	6000	5.9	5.9	741.0	5906675403274
	R-HPTIIZFD12100/5 ¹⁾	12	100	50	50	6000	6.6	6.6	825.2	5906675403281
	R-HPTIIZFD12120/25 ¹⁾	12	120	50	50	6000	7.3	7.3	901.8	5906675403298
	R-HPTIIZFD12135/40 ¹⁾	12	135	50	50	3800	7.9	7.9	632.2	5906675403304
	R-HPTIIZFD12150/55 ¹⁾	12	150	50	50	7600	8.4	8.4	1312.9	5906675403311
M16	R-HPTIIZFD16105/10 ¹⁾	16	105	25	25	3600	6.5	6.5	965.7	5906675403335
	R-HPTIIZFD16140/20 ¹⁾	16	140	25	25	4000	7.6	7.6	1245.2	5906675403342
	R-HPTIIZFD16180/60 ¹⁾	16	180	25	25	1900	9.0	9.0	714.8	5906675403359
M20	R-HPTIIZFD20125/5 ¹⁾	20	125	25	25	1900	11.2	11.2	880.7	5906675403366
	R-HPTIIZFD20160/20 ¹⁾	20	160	25	25	1900	13.1	13.1	1027.7	5906675403373

¹⁾ ETA 17/0184

R-XPTIIA4 Stainless Steel Throughbolt

Stainless steel throughbolt for non-cracked concrete



Approvals and Reports

- ETA 17/0782
- AT-15-7370/2016



Installation movie

Product overview

Features and benefits

- Stainless steel anchor for the highest corrosion resistance
- High performance in non-cracked concrete confirmed by ETA Option 7
- Highest quality ensures maximum load capability
- Fire resistant
- Suitable for reduced embedment to avoid contact with reinforcement
- Embedment depth markings help to ensure precise installation of the anchor
- Simple through-installation (drilling and installation through fixed material)

Applications

- Cladding restraint
- Curtain wall
- Balustrading
- Barriers
- Handrails
- Racking
- Structural steel
- Bollards

Base materials

Approved for use in:

- Non-cracked concrete C20/25-C50/60
- Unreinforced concrete
- Reinforced concrete

Also suitable for use in:

- Natural stone (after site testing)

Installation guide



1. Drill a hole of required diameter and depth
2. Clear the hole of drilling dust and debris (using blow pump and brush or equivalent method)
3. Lightly tap the throughbolt through the fixture into hole with a hammer, until fixing depth is reached
4. Tighten to the recommended torque

Product information

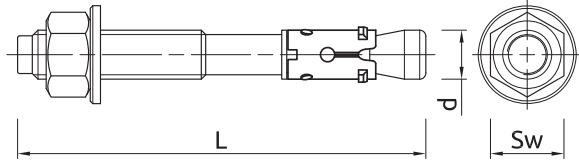

Size	Product Code	Approval type	Anchor		Fixture		
			Diameter	Length	Max. thickness t_{fix} for:		Hole diameter
			d	L	$h_{nom,red}$	$h_{nom,std}$	d_f
		-	[mm]	[mm]	[mm]	[mm]	[mm]
M6	R-XPTIIA4-06050/10	AT-15-7370/16	6	50	10	-	7
	R-XPTIIA4-06085/25	AT-15-7370/16	6	85	45	25	7
M8	R-XPTIIA4-08060/10	ETA 17/0782	8	60	10	-	9
	R-XPTIIA4-08075/10	ETA 17/0782	8	75	25	10	9
	R-XPTIIA4-08085/20	ETA 17/0782	8	85	35	20	9
	R-XPTIIA4-08095/30	ETA 17/0782	8	95	45	30	9
	R-XPTIIA4-08105/40	ETA 17/0782	8	105	55	40	9
	R-XPTIIA4-08115/50	ETA 17/0782	8	115	65	50	9
M10	R-XPTIIA4-10065/5	ETA 17/0782	10	65	5	-	11
	R-XPTIIA4-10080/20	ETA 17/0782	10	80	20	-	11
	R-XPTIIA4-10095/15	ETA 17/0782	10	95	35	15	11
	R-XPTIIA4-10115/35	ETA 17/0782	10	115	55	35	11
	R-XPTIIA4-10130/50	ETA 17/0782	10	130	70	50	11
	R-XPTIIA4-10140/60	ETA 17/0782	10	140	80	60	11
M12	R-XPTIIA4-12080/5	ETA 17/0782	12	80	5	-	13
	R-XPTIIA4-12100/5	ETA 17/0782	12	100	25	5	13
	R-XPTIIA4-12115/20	ETA 17/0782	12	115	40	20	13
	R-XPTIIA4-12125/30	ETA 17/0782	12	125	50	30	13
	R-XPTIIA4-12150/55	ETA 17/0782	12	150	75	55	13
	R-XPTIIA4-12180/85	ETA 17/0782	12	180	105	85	13
M16	R-XPTIIA4-16125/5	ETA 17/0782	16	125	25	5	18
	R-XPTIIA4-16140/20	ETA 17/0782	16	140	40	20	18
	R-XPTIIA4-16150/30	ETA 17/0782	16	150	50	30	18
	R-XPTIIA4-16180/60	ETA 17/0782	16	180	80	60	18
M20	R-XPTIIA4-20125/5	AT-15-7370/16	20	125	5	-	22
	R-XPTIIA4-20160/20	AT-15-7370/16	20	160	40	20	22
	R-XPTIIA4-20200/60	AT-15-7370/16	20	200	80	60	22
	R-XPTIIA4-20300/16	AT-15-7370/16	20	300	180	160	22
M24	R-XPTIIA4-24260/10	AT-15-7370/16	24	260	115	100	26

Installation data

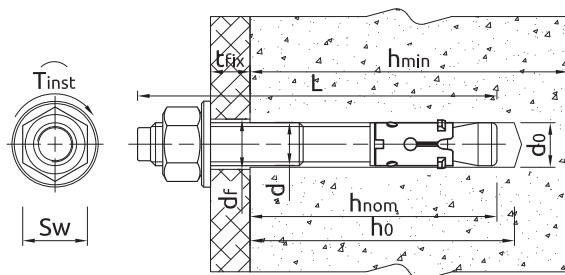

All products listed in this publication are branded and distributed with RAWLPLUG® or RAWL® trademarks.

Installation data (cont.)

Size			M6	M8	M10	M12	M16	M20	M24
Thread diameter	d	[mm]	6	8	10	12	16	20	24
Hole diameter in substrate	d ₀	[mm]	6	8	10	12	16	20	24
Installation torque	T _{inst}	[Nm]	5	15	30	50	100	180	320
Wrench size	Sw	[mm]	10	13	17	19	24	30	36
STANDARD EMBEDMENT DEPTH									
Min. hole depth in substrate	h _{0,s}	[mm]	55	65	79	90	110	140	230
Installation depth	h _{nom,s}	[mm]	50	55	69	80	100	120	135
Min. substrate thickness	h _{min,s}	[mm]	100	100	120	140	170	210	155
Min. spacing (Non-cracked concrete)	s _{min,s}	[mm]	45	65	90	110	170	170	180
Min. edge distance (Non-cracked concrete)	c _{min,s}	[mm]	50	50	60	85	90	160	200
REDUCED EMBEDMENT DEPTH									
Min. hole depth in substrate	h _{0,r}	[mm]	40	50	59	70	90	120	140
Installation depth	h _{nom,r}	[mm]	30	40	49	60	80	100	120
Min. substrate thickness	h _{min,r}	[mm]	100	100	100	100	130	210	230
Min. spacing (Non-cracked concrete)	s _{min,r}	[mm]	40	65	115	150	190	160	190
Min. edge distance (Non-cracked concrete)	c _{min,r}	[mm]	45	50	80	100	120	125	160

Mechanical properties

Size			M6	M8	M10	M12	M16	M20	M24
Nominal ultimate tensile strength - tension	F _{uk}	[N/mm ²]	800	600	600	550	550	500	500
Nominal yield strength - tension	F _{yk}	[N/mm ²]	600	480	480	440	440	210	210
Cross sectional area - tension	A _s	[mm ²]	14.25	25.5	40.7	60.1	106.6	162.9	234.52
Elastic section modulus	W _{el}	[mm ³]	13.15	31.2	62.3	109	276.4	539.9	940.9
Characteristic bending resistance	M ⁰ _{Rk,s}	[Nm]	12.62	22	45	72	180	323.9	564.54
Design bending resistance	M	[Nm]	9.49	17.6	36	57.6	144	136.11	237.2

Basic performance data

Performance data for single anchor without influence of edge distance and spacing

Size		M6	M8	M10	M12	M16	M20	M24
TENSION LOAD N_{Rk}								
Standard embedment depth	[kN]	7.50	9.00	16.00	25.00	39.57	20.00	25.00
Reduced embedment depth	[kN]	1.50	7.50	12.00	16.79	26.46	12.00	16.00
SHEAR LOAD V_{Rk}								
Standard embedment depth	[kN]	7.50	11.70	18.50	24.60	45.40	40.00	50.00
Reduced embedment depth	[kN]	1.50	9.14	12.30	16.79	45.40	24.00	32.00
DESIGN LOAD								
TENSION LOAD N_{Rk}								
Standard embedment depth	[kN]	2.97	5.00	10.67	16.67	26.38	7.94	9.92
Reduced embedment depth	[kN]	0.59	4.17	6.67	11.20	17.64	4.76	6.35
SHEAR LOAD V_{Rk}								
Standard embedment depth	[kN]	6.00	9.36	14.80	19.68	36.32	32.00	40.00
Reduced embedment depth	[kN]	1.20	6.09	8.20	11.20	35.29	19.20	25.60
RECOMMENDED LOAD								
TENSION LOAD N_{rec}								
Standard embedment depth	[kN]	2.12	3.57	7.62	11.90	18.85	5.67	7.09
Reduced embedment depth	[kN]	0.42	2.98	4.76	8.00	12.60	3.40	4.54
SHEAR LOAD V_{rec}								
Standard embedment depth	[kN]	4.28	6.69	10.57	14.06	25.94	22.85	28.57
Reduced embedment depth	[kN]	0.85	4.35	5.86	8.00	25.20	13.71	18.28

Product commercial data

Size	Product Code	Anchor		Quantity [pcs]			Weight [kg]			Bar Codes
		Diameter [mm]	Length [mm]	Box	Outer	Pallet	Box	Outer	Pallet	
M6	R-XPTIIA4-06050/10*	6	50	100	100	16000	1.27	1.27	233.0	5906675100081
	R-XPTIIA4-06085/25*	6	85	100	100	16000	1.84	1.84	324.6	5906675100104
M8	R-XPTIIA4-08060/10	8	60	100	100	16000	2.6	2.6	445.8	5906675047232
	R-XPTIIA4-08075/10	8	75	100	100	16000	3.1	3.1	519.6	5906675047249
	R-XPTIIA4-08085/20	8	85	100	100	16000	3.4	3.4	570.8	5906675047256
	R-XPTIIA4-08095/30	8	95	100	100	16000	3.7	3.7	473.9	5906675047263
	R-XPTIIA4-08105/40	8	105	100	100	16000	4.0	4.0	671.8	5906675047270
	R-XPTIIA4-08115/50	8	115	100	100	16000	4.3	4.3	721.7	5906675047287
M10	R-XPTIIA4-10065/5	10	65	50	50	8000	2.4	2.4	409.8	5906675047294
	R-XPTIIA4-10080/20	10	80	50	50	8000	2.8	2.8	470.6	5906675047300
	R-XPTIIA4-10095/15	10	95	50	50	8000	3.1	3.1	529.7	5906675047317
	R-XPTIIA4-10115/35	10	115	50	50	6000	3.7	3.7	470.3	5906675047324
	R-XPTIIA4-10130/50	10	130	50	50	6000	4.0	4.0	510.1	5906675047331
	R-XPTIIA4-10140/60	10	140	50	50	8000	4.2	4.2	708.7	5906675047348
M12	R-XPTIIA4-12080/5	12	80	50	50	8000	4.1	4.1	684.1	5906675047355
	R-XPTIIA4-12100/5	12	100	50	50	8000	4.8	4.8	799.1	5906675047362
	R-XPTIIA4-12115/25	12	115	50	50	6000	5.4	5.4	676.8	5906675324548
	R-XPTIIA4-12125/30	12	125	50	50	6000	5.8	5.8	720.5	5906675047379
	R-XPTIIA4-12150/55	12	150	50	50	4000	6.7	6.7	562.2	5906675047386
	R-XPTIIA4-12180/85	12	180	50	50	4000	7.8	7.8	652.1	5906675047393
M16	R-XPTIIA4-16125/5	16	125	25	25	4000	5.3	5.3	875.6	5906675047409
	R-XPTIIA4-16140/20	16	140	25	25	4000	5.8	5.8	956.9	5906675047416
	R-XPTIIA4-16150/30	16	150	25	25	4000	5.7	5.7	946.0	5906675047430
	R-XPTIIA4-16180/60	16	180	25	25	3000	7.1	7.1	886.1	5906675047447
M20	R-XPTIIA4-20125/5*	20	125	25	25	3000	8.5	8.5	1048.7	5906675100241
	R-XPTIIA4-20160/20*	20	160	25	25	3000	10.4	10.4	1271.9	5906675100364
	R-XPTIIA4-20200/60*	20	200	10	10	1200	5.0	5.0	631.4	5906675100401
	R-XPTIIA4-20300/160*	20	300	10	10	1200	7.1	7.1	884.4	5906675100418
M24	R-XPTIIA4-24260/100*	24	260	10	10	1200	9.5	9.5	1168.6	5906675100432

* AT-15-7370/2016

R-XPT Throughbolt

Throughbolt for non-cracked concrete

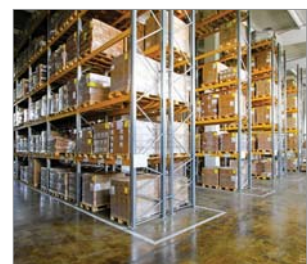

Approvals and Reports

- ETA 17/0183
- AT-15-9327/2014



Installation movie

Product overview

Features and benefits

- High performance in non-cracked concrete confirmed by ETA Option 7
- Suitable for reduced embedment to avoid contact with reinforcement
- Embedment depth markings help to ensure precise installation of the anchor
- Design allows drilling and installing directly through the fixture and helps to reduce installation time
- Cold formed body ensures consistent dimensional accuracy
- Simple through-installation (drilling and installation through fixed material)
- Optimized expander design with six grip features allows for a high load-bearing capacity
- Zinc plated passivated steel with clear Cr3 zinc layer of thickness not thinner than 5 µm according to EN ISO 4042

Applications

- Cladding restraint
- Curtain wall
- Balustrading
- Barriers
- Handrails
- Racking
- Structural steel
- Bollards

Base materials

Approved for use in:

- Non-cracked concrete C20/25-C50/60
- Unreinforced concrete
- Reinforced concrete

Also suitable for use in:

- Natural stone (after site testing)

Installation guide



1. Drill a hole of required diameter and depth
2. Clear the hole of drilling dust and debris (using blow pump and brush or equivalent method)
3. Lightly tap the throughbolt through the fixture into hole with a hammer, until fixing depth is reached
4. Tighten to the recommended torque

Product information

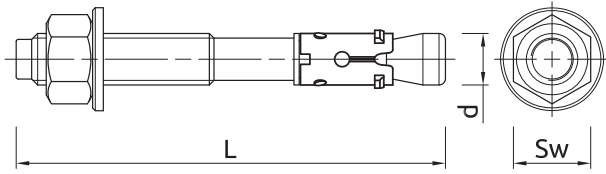

Size	Product Code	Anchor		Fixture		
		Diameter	Length	Max. thickness t_{fix} for:		Hole diameter
		d	L	$h_{nom,red}$	$h_{nom,std}$	d_f
		[mm]	[mm]	[mm]	[mm]	[mm]
M6	R-XPT-06050/10	6	50	10	-	7
	R-XPT-06065/5	6	65	25	5	7
	R-XPT-06085/25	6	85	45	25	7
	R-XPT-06100/40	6	100	60	40	7
M8	R-XPT-08050/5	8	50	5	-	9
	R-XPT-08060/10	8	60	10	-	9
	R-XPT-08065/15	8	65	15	-	9
	R-XPT-08075/10	8	75	25	10	9
	R-XPT-08080/15	8	80	30	15	9
	R-XPT-08085/20	8	85	35	20	9
	R-XPT-08095/30	8	95	45	30	9
	R-XPT-08115/50	8	115	65	50	9
	R-XPT-08140/75	8	140	90	75	9
	R-XPT-08150/85	8	150	100	85	9
M10	R-XPT-10065/5	10	65	5	-	11
	R-XPT-10080/10	10	80	20	10	11
	R-XPT-10095/25	10	95	35	25	11
	R-XPT-10115/45	10	115	55	45	11
	R-XPT-10130/60	10	130	70	60	11
	R-XPT-10140/70	10	140	80	70	11
	R-XPT-10150/80	10	150	90	80	11
M12	R-XPT-10180/110	10	180	120	110	11
	R-XPT-12080/5	12	80	5	-	13
	R-XPT-12100/5	12	100	25	5	13
	R-XPT-12120/25	12	120	45	25	13
	R-XPT-12125/30	12	125	50	30	13
	R-XPT-12135/40	12	135	60	40	13
	R-XPT-12140/45	12	140	65	45	13
	R-XPT-12150/55	12	150	75	55	13
	R-XPT-12160/65	12	160	85	65	13
	R-XPT-12180/85	12	180	105	85	13
	R-XPT-12200/105	12	200	125	105	13
	R-XPT-12220/125	12	220	145	125	13
	R-XPT-12250/155	12	250	175	155	13
R-XPT-12280/185	12	280	205	185	13	
M16	R-XPT-16100/5	16	100	5	-	18
	R-XPT-16105/10	16	105	10	-	18
	R-XPT-16125/5	16	125	25	5	18
	R-XPT-16140/20	16	140	40	20	18
	R-XPT-16150/30	16	150	50	30	18
	R-XPT-16160/40	16	160	60	40	18
	R-XPT-16180/60	16	180	80	60	18
	R-XPT-16200/80	16	200	100	80	18
	R-XPT-16220/100	16	220	120	100	18
	R-XPT-16250/130	16	250	150	130	18
	R-XPT-16280/160	16	280	180	160	18
R-XPT-16300/180	16	300	200	180	18	

All products listed in this publication are branded and distributed with RAWLPLUG® or RAWL® trademarks.

R-XPT-HD Hot Dip Galvanized Throughbolt

Hot Dip Galvanized throughbolt for non-cracked concrete



Approvals and Reports

- AT-15-9326/2014



Product overview

Features and benefits

- Increased corrosion resistance due to hot dip zinc external protection layer
- R-XPT-HD is suitable for reduced embedment to avoid contact with reinforcement
- Embedment depth markings help to ensure precise installation of the anchor
- Design allows drilling and installing directly through the fixture and helps to reduce installation time
- High quality with cost effectiveness
- Cold formed body ensures consistent dimensional accuracy

Applications

- Cladding restraint
- Curtain wall
- Balustrading
- Barriers
- Handrails
- Racking
- Structural steel
- Bollards

Base materials

Approved for use in:

- Non-cracked concrete C20/25-C50/60
- Unreinforced concrete
- Reinforced concrete

Also suitable for use in:

- Natural stone (after site testing)

Installation guide



1. Drill a hole of required diameter and depth
2. Clear the hole of drilling dust and debris (using blow pump and brush or equivalent method)
3. Lightly tap the throughbolt through the fixture into hole with a hammer, until fixing depth is reached
4. Tighten to the recommended torque

Product information

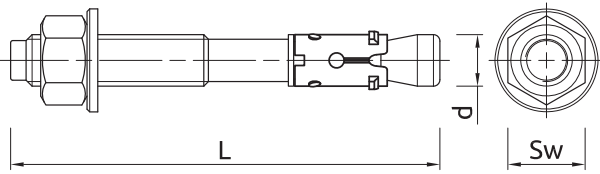

Size	Product Code	Anchor		Fixture		
		Diameter	Length	Max. thickness		Hole diameter
		d	L	$t_{fix,r}$	$t_{fix,s}$	d_f
		[mm]	[mm]	[mm]	[mm]	[mm]
M6	R-XPT-HD-06050/10	6	50	10	-	7
	R-XPT-HD-06085/25	6	85	45	25	7
	R-XPT-HD-06100/40	6	100	60	40	7
M8	R-XPT-HD-08050/5	8	50	5	-	9
	R-XPT-HD-08060/10	8	60	10	-	9
	R-XPT-HD-08065/15	8	65	15	-	9
	R-XPT-HD-08075/10	8	75	25	10	9
	R-XPT-HD-08080/15	8	80	30	15	9
	R-XPT-HD-08095/30	8	95	45	30	9
	R-XPT-HD-08115/50	8	115	65	50	9
	R-XPT-HD-08140/75	8	140	90	75	9
M10	R-XPT-HD-10065/5	10	65	5	-	11
	R-XPT-HD-10080/10	10	80	20	10	11
	R-XPT-HD-10095/25	10	95	35	25	11
	R-XPT-HD-10115/45	10	115	55	45	11
	R-XPT-HD-10130/60	10	130	70	60	11
	R-XPT-HD-10140/70	10	140	80	70	11
M12	R-XPT-HD-12080/5	12	80	5	-	13
	R-XPT-HD-12100/5	12	100	25	5	13
	R-XPT-HD-12120/25	12	120	45	25	13
	R-XPT-HD-12125/30	12	125	50	30	13
	R-XPT-HD-12135/40	12	135	60	40	13
	R-XPT-HD-12150/55	12	150	75	55	13
	R-XPT-HD-12180/85	12	180	105	85	13
R-XPT-HD-12220/125	12	220	145	125	13	
M16	R-XPT-HD-16100/5	16	100	5	-	18
	R-XPT-HD-16105/10	16	105	10	-	18
	R-XPT-HD-16125/5	16	125	25	5	18
	R-XPT-HD-16140/20	16	140	40	20	18
	R-XPT-HD-16150/30	16	150	50	30	18
	R-XPT-HD-16180/60	16	180	80	60	18
	R-XPT-HD-16220/100	16	220	120	100	18
M20	R-XPT-HD-20125/5	20	125	5	-	22
	R-XPT-HD-20160/20	20	160	40	20	22
	R-XPT-HD-20200/60	20	200	80	60	22
M24	R-XPT-HD-24260/100	24	260	115	100	26

Installation data

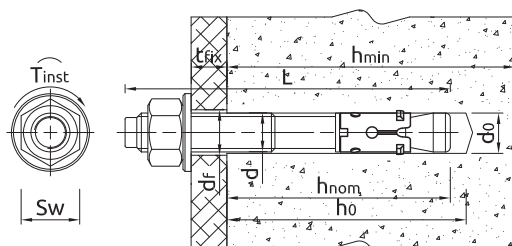

All products listed in this publication are branded and distributed with RAWPLUG® or RAWL® trademarks.

Installation data

Size			M6	M8	M10	M12	M16	M20	M24
Thread diameter	d	[mm]	6	8	10	12	16	20	24
Hole diameter in substrate	d ₀	[mm]	6	8	10	12	16	20	24
Installation torque	T _{inst}	[Nm]	5	15	30	50	100	200	300
Wrench size	Sw	[mm]	10	13	17	19	24	30	36
STANDARD EMBEDMENT DEPTH									
Min. hole depth in substrate	h _{0,s}	[mm]	55	60	65	85	105	125	140
Installation depth	h _{nom,s}	[mm]	50	55	59	80	100	119	135
Min. substrate thickness	h _{min,s}	[mm]	84	100	100	136	170	198	224
Min. spacing	s _{min,s}	[mm]	45	50	55	75	90	140	180
Min. edge distance	c _{min,s}	[mm]	50	40	50	65	80	100	200
REDUCED EMBEDMENT DEPTH									
Min. hole depth in substrate	h _{0,r}	[mm]	35	45	55	65	85	105	125
Installation depth	h _{nom,r}	[mm]	30	40	49	60	80	99	120
Min. substrate thickness	h _{min,r}	[mm]	80	100	100	100	130	158	194
Min. spacing	s _{min,r}	[mm]	40	45	55	100	100	125	160
Min. edge distance	c _{min,r}	[mm]	45	40	65	100	100	125	160

Mechanical properties

Size			M6	M8	M10	M12	M16	M20	M24
Nominal ultimate tensile strength - tension	f _{uk}	[N/mm ²]	400	400	400	400	400	480	480
Nominal ultimate tensile strength - shear	f _{uk}	[N/mm ²]	520	520	520	520	520	520	680
Nominal yield strength - tension	f _{yk}	[N/mm ²]	539	531	531	531	531	531	496
Nominal yield strength - shear	f _{yk}	[N/mm ²]	416	416	416	416	416	416	544
Cross sectional area - tension	A _s	[mm ²]	15.2	25.5	40.7	60.1	106.6	162.9	311
Cross sectional area - shear	A _s	[mm ²]	20.1	36.6	58	84.3	157	245	353
Elastic section modulus	W _{el}	[mm ³]	12.7	31.2	62.3	109.2	277.5	540.9	935.5
Characteristic bending resistance	M ⁰ _{Rk,s}	[Nm]	7.1	17	35	61	155	302	651
Design bending resistance	M	[Nm]	5.7	14	28	49	124	241	521

Basic performance data

Performance data for single anchor without influence of edge distance and spacing

Size		M6	M8	M10	M12	M16	M20	M24
NON-CRACKED CONCRETE								
CHARACTERISTIC LOAD								
TENSION LOAD N_{Rk}								
Standard embedment depth	[kN]	6.85	9.72	12.61	20.17	27.59	35.02	41.89
Reduced embedment depth	[kN]	2.98	6.05	8.87	12.87	19.36	28.05	35.56
SHEAR LOAD V_{Rk}								
Standard embedment depth	[kN]	5.50	9.72	12.61	23.30	43.00	67.40	83.78
Reduced embedment depth	[kN]	2.98	6.05	8.87	12.87	38.72	56.10	70.72
DESIGN LOAD								
TENSION LOAD N_{Rd}								
Standard embedment depth	[kN]	2.72	3.86	5.00	8.00	10.95	13.90	16.62
Reduced embedment depth	[kN]	1.18	2.40	3.52	5.11	7.68	11.13	14.03
SHEAR LOAD V_{Rd}								
Standard embedment depth	[kN]	2.72	3.86	5.00	16.01	21.90	27.79	33.25
Reduced embedment depth	[kN]	1.18	2.40	3.52	5.11	15.37	22.26	28.06

Basic performance data (cont.)

Performance data for single anchor without influence of edge distance and spacing

Size		M6	M8	M10	M12	M16	M20	M24
RECOMMENDED LOAD								
TENSION LOAD N_{rec}								
Standard embedment depth	[kN]	1.94	2.76	3.57	5.72	7.82	9.93	11.87
Reduced embedment depth	[kN]	0.84	1.71	2.51	3.65	5.49	7.95	10.02
SHEAR LOAD V_{rec}								
Standard embedment depth	[kN]	1.94	2.76	3.57	11.43	15.64	19.86	23.75
Reduced embedment depth	[kN]	0.84	1.71	2.51	3.65	10.98	15.80	20.05

Product commercial data

Size	Product Code	Anchor		Quantity [pcs]			Weight [kg]			Bar Codes
		Diameter [mm]	Length [mm]	Box	Outer	Pallet	Box	Outer	Pallet	
M6	R-XPT-HD-06050/10	6	50	100	100	16000	1.32	1.32	241.2	5906675277844
	R-XPT-HD-06085/25	6	85	100	100	16000	2.0	2.0	342.0	5906675277851
	R-XPT-HD-06100/40	6	100	100	100	16000	2.2	2.2	385.2	5906675277868
M8	R-XPT-HD-08050/5	8	50	100	100	16000	2.3	2.3	404.4	5906675277875
	R-XPT-HD-08060/10	8	60	100	100	16000	2.8	2.8	470.0	5906675234007
	R-XPT-HD-08065/15	8	65	100	100	16000	2.9	2.9	490.8	5906675277882
	R-XPT-HD-08075/10	8	75	100	100	16000	3.2	3.2	542.0	5906675234014
	R-XPT-HD-08080/15	8	80	100	100	16000	3.3	3.3	553.2	5906675277899
	R-XPT-HD-08095/30	8	95	100	100	12000	3.8	3.8	482.4	5906675234618
	R-XPT-HD-08115/50	8	115	100	100	12000	4.4	4.4	561.6	5906675234038
	R-XPT-HD-08140/75	8	140	100	100	16000	5.2	5.2	865.2	5906675234045
M10	R-XPT-HD-10065/5	10	65	50	50	8000	2.4	2.4	414.0	5906675234052
	R-XPT-HD-10080/10	10	80	50	50	8000	2.8	2.8	473.2	5906675234069
	R-XPT-HD-10095/25	10	95	50	50	8000	3.2	3.2	534.8	5906675234076
	R-XPT-HD-10115/45	10	115	50	50	6000	3.7	3.7	472.2	5906675234083
	R-XPT-HD-10130/60	10	130	50	50	8000	4.0	4.0	676.4	5906675277905
	R-XPT-HD-10140/70	10	140	50	50	8000	4.4	4.4	728.4	5906675234090
M12	R-XPT-HD-12080/5	12	80	50	50	8000	4.1	4.1	684.4	5906675234106
	R-XPT-HD-12100/5	12	100	50	50	8000	4.8	4.8	799.6	5906675234113
	R-XPT-HD-12120/25	12	120	50	50	6000	5.6	5.6	698.4	5906675277912
	R-XPT-HD-12125/30	12	125	50	50	6000	5.7	5.7	717.0	5906675234625
	R-XPT-HD-12135/40	12	135	50	50	6000	6.3	6.3	781.8	5906675277929
	R-XPT-HD-12150/55	12	150	50	50	6000	6.7	6.7	831.0	5906675234137
	R-XPT-HD-12180/85	12	180	50	50	4000	7.8	7.8	656.0	5906675234144
R-XPT-HD-12220/125	12	220	50	50	4000	9.3	9.3	775.6	5906675234151	
M16	R-XPT-HD-16100/5	16	100	25	25	4000	4.4	4.4	733.2	5906675234168
	R-XPT-HD-16105/10	16	105	25	25	4000	4.0	4.0	661.2	5906675277936
	R-XPT-HD-16125/5	16	125	25	25	4000	5.4	5.4	890.0	5906675234175
	R-XPT-HD-16140/20	16	140	25	25	4000	5.9	5.9	975.2	5906675277943
	R-XPT-HD-16150/30	16	150	25	25	4000	6.1	6.1	1003.6	5906675249728
	R-XPT-HD-16180/60	16	180	25	25	3000	7.2	7.2	898.8	5906675249735
	R-XPT-HD-16220/100	16	220	25	25	3000	8.4	8.4	1040.1	5906675234205
M20	R-XPT-HD-20125/5	20	125	25	25	3000	8.5	8.5	1051.2	5906675234212
	R-XPT-HD-20160/20	20	160	25	25	2000	10.3	10.3	855.6	5906675234229
	R-XPT-HD-20200/60	20	200	10	10	1200	5.0	5.0	624.1	5906675234236
M24	R-XPT-HD-24260/100	24	260	10	10	1200	9.4	9.4	1155.5	5906675249742

All products listed in this publication are branded and distributed with RAWLPLUG® or RAWL® trademarks.

Product information (cont.)

Size	Product Code	Anchor		Fixture		
		Diameter	Length	Max. thickness t_{fix} for:		Hole diameter
		d	L	$h_{nom,red}$	$h_{nom,std}$	d_f
		[mm]	[mm]	[mm]	[mm]	[mm]
M20	R-XPT-20125/5	20	125	5	-	22
	R-XPT-20160/20	20	160	40	20	22
	R-XPT-20200/60	20	200	80	60	22
	R-XPT-20250/110	20	250	130	110	22
	R-XPT-20300/160	20	300	180	160	22
M24	R-XPT-24180/20	24	180	35	20	26
	R-XPT-24260/100	24	260	115	100	26
	R-XPT-24300/140	24	300	155	140	26

Installation data

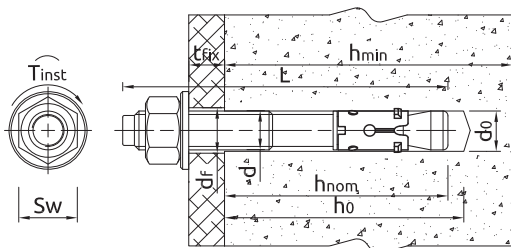

Size			M6	M8	M10	M12	M16	M20	M24
Thread diameter	d	[mm]	6	8	10	12	16	20	24
Hole diameter in substrate	d_0	[mm]	6	8	10	12	16	20	24
Installation torque	T_{inst}	[Nm]	5	15	30	50	100	200	300
Wrench size	Sw	[mm]	10	13	17	19	24	30	36
STANDARD EMBEDMENT DEPTH									
Min. hole depth in substrate	$h_{0,s}$	[mm]	55	55	59	80	100	119	140
Installation depth	$h_{nom,s}$	[mm]	50	55	59	80	100	119	135
Min. substrate thickness	$h_{min,s}$	[mm]	84	100	100	136	170	198	224
Min. spacing	$s_{min,s}$	[mm]	45	50	55	75	90	140	180
Min. edge distance	$c_{min,s}$	[mm]	50	40	50	65	80	100	200
REDUCED EMBEDMENT DEPTH									
Min. hole depth in substrate	$h_{0,r}$	[mm]	35	40	49	60	80	100	125
Installation depth	$h_{nom,r}$	[mm]	30	40	49	60	80	100	120
Min. substrate thickness	$h_{min,r}$	[mm]	80	100	100	100	130	158	194
Min. spacing	$s_{min,r}$	[mm]	40	45	55	100	100	125	160
Min. edge distance	$c_{min,r}$	[mm]	45	40	65	100	100	125	160

Mechanical properties

Size			M6	M8	M10	M12	M16	M20	M24
Nominal ultimate tensile strength - tension	f_{uk}	[N/mm ²]	620	620	620	620	620	620	620
Nominal yield strength - tension	f_{yk}	[N/mm ²]	531	531	531	531	531	531	531
Cross sectional area - tension	A_s	[mm ²]	14.25	25.5	40.7	60.1	106.6	162.9	234.52
Elastic section modulus	W_{el}	[mm ³]	13.15	31.2	62.3	109	276.4	539.9	940.9
Characteristic bending resistance	$M^0_{Rk,s}$	[Nm]	7	17	35	61	154	301	525
Design bending resistance	M	[Nm]	5.6	13.6	28	48.8	123.2	240.8	420

Basic performance data

Performance data for single anchor without influence of edge distance and spacing

Size		M6	M8	M10	M12	M16	M20	M24
Standard embedment depth h_{ef}	[mm]	42	47	49	68	85	99	112
Reduced embedment depth h_{ef}	[mm]	22	32	39	48	65	79	97
CHARACTERISTIC LOAD								
TENSION LOAD N_{Rk}								
Standard embedment depth	[kN]	8.67	12.00	12.00	25.00	39.57	40.00	38.14
Reduced embedment depth	[kN]	4.27	9.00	9.00	16.00	26.46	35.00	31.92
SHEAR LOAD V_{Rk}								
Standard embedment depth	[kN]	5.50	10.10	16.0	23.30	43.00	67.40	97.10
Reduced embedment depth	[kN]	5.50	9.14	9.14	16.79	43.00	67.40	97.10
DESIGN LOAD								
TENSION LOAD N_{Rd}								
Standard embedment depth	[kN]	3.44	6.67	6.67	13.89	21.99	22.22	15.13
Reduced embedment depth	[kN]	1.69	5.00	5.00	8.89	14.70	19.44	12.67
SHEAR LOAD V_{Rd}								
Standard embedment depth	[kN]	4.40	8.08	11.55	18.64	34.40	53.92	77.68
Reduced embedment depth	[kN]	4.40	6.09	6.09	11.20	34.40	42.28	77.68
RECOMMENDED LOAD								
TENSION LOAD N_{rec}								
Standard embedment depth	[kN]	2.46	4.76	4.76	9.92	15.70	15.87	10.81
Reduced embedment depth	[kN]	1.21	3.57	3.60	6.35	10.50	13.89	9.05
SHEAR LOAD V_{rec}								
Standard embedment depth	[kN]	3.14	5.77	8.25	13.31	24.57	38.51	55.49
Reduced embedment depth	[kN]	3.14	4.35	4.35	8.00	24.57	33.77	55.49

Product commercial data

Size	Product Code	Anchor		Quantity [pcs]			Weight [kg]			Bar Codes
		Diameter [mm]	Length [mm]	Box	Outer	Pallet	Box	Outer	Pallet	
M6	R-XPT-06050/10*	6	50	100	100	16000	1.27	1.27	233.2	5906675233499
	R-XPT-06065/5*	6	65	100	100	16000	1.55	1.55	278.0	5906675233505
	R-XPT-06085/25*	6	85	100	100	16000	1.85	1.85	326.0	5906675233512
	R-XPT-06100/40*	6	100	100	100	16000	2.1	2.1	370.8	5906675250311
M8	R-XPT-08050/5	8	50	100	100	16000	2.3	2.3	396.4	5906675250328
	R-XPT-08060/10	8	60	100	100	16000	2.6	2.6	446.0	5906675234601
	R-XPT-08065/15	8	65	100	100	16000	2.7	2.7	465.2	5906675250335
	R-XPT-08075/10	8	75	100	100	16000	3.1	3.1	518.0	5906675233536
	R-XPT-08080/15	8	80	100	100	16000	3.2	3.2	542.0	5906675250342
	R-XPT-08085/20	8	85	100	100	16000	3.4	3.4	578.8	5906675249636
	R-XPT-08095/30	8	95	100	100	12000	3.7	3.7	469.2	5906675233543
	R-XPT-08115/50	8	115	100	100	12000	4.3	4.3	540.0	5906675233550
	R-XPT-08140/75	8	140	100	100	16000	5.2	5.2	855.6	5906675233567
R-XPT-08150/85	8	150	100	100	16000	5.4	5.4	887.6	5906675250359	

Product commercial data

Size	Product Code	Anchor		Quantity [pcs]			Weight [kg]			Bar Codes
		Diameter [mm]	Length [mm]	Box	Outer	Pallet	Box	Outer	Pallet	
M10	R-XPT-10065/5	10	65	50	50	8000	2.4	2.4	408.4	5906675233574
	R-XPT-10080/10	10	80	50	50	8000	2.7	2.7	468.4	5906675233581
	R-XPT-10095/25	10	95	50	50	8000	3.1	3.1	527.6	5906675233598
	R-XPT-10115/45	10	115	50	50	6000	3.6	3.6	463.2	5906675233604
	R-XPT-10130/60	10	130	50	50	8000	4.0	4.0	664.4	5906675249643
	R-XPT-10140/70	10	140	50	50	8000	4.2	4.2	705.2	5906675233611
	R-XPT-10150/80	10	150	50	50	8000	4.5	4.5	742.0	5906675249650
	R-XPT-10180/110	10	180	50	50	6000	5.2	5.2	654.6	5906675250366
M12	R-XPT-12080/5	12	80	50	50	8000	4.1	4.1	678.0	5906675233628
	R-XPT-12100/5	12	100	50	50	8000	4.8	4.8	792.4	5906675233635
	R-XPT-12120/25	12	120	50	50	6000	5.5	5.5	690.0	5906675250373
	R-XPT-12125/30	12	125	50	50	6000	5.7	5.7	709.2	5906675233642
	R-XPT-12135/40	12	135	50	50	6000	6.1	6.1	757.8	5906675250380
	R-XPT-12140/45	12	140	50	50	6000	6.2	6.2	769.2	5906675249667
	R-XPT-12150/55	12	150	50	50	4000	6.6	6.6	558.4	5906675233659
	R-XPT-12160/65	12	160	50	50	4000	6.9	6.9	584.4	5906675216416
	R-XPT-12180/85	12	180	50	50	4000	7.6	7.6	639.2	5906675233666
	R-XPT-12200/105	12	200	50	50	4000	8.3	8.3	696.4	5906675312132
	R-XPT-12220/125	12	220	50	50	4000	9.1	9.1	755.2	5906675233673
	R-XPT-12250/155	12	250	25	25	3000	5.1	5.1	637.8	5906675312149
R-XPT-12280/185	12	280	20	20	1600	4.6	4.6	395.8	5906675312156	
M16	R-XPT-16100/5	16	100	25	25	4000	4.4	4.4	731.6	5906675233680
	R-XPT-16105/10	16	105	25	25	4000	4.6	4.6	763.6	5906675250403
	R-XPT-16125/5	16	125	25	25	4000	5.3	5.3	869.6	5906675233697
	R-XPT-16140/20	16	140	25	25	4000	5.7	5.7	948.4	5906675249063
	R-XPT-16150/30	16	150	25	25	4000	6.1	6.1	1001.2	5906675249674
	R-XPT-16160/40	16	160	25	25	3000	6.4	6.4	792.9	5906675250410
	R-XPT-16180/60	16	180	25	25	3000	7.0	7.0	873.3	5906675249681
	R-XPT-16200/80	16	200	25	25	3000	12.5	12.5	1530.0	5906675312163
	R-XPT-16220/100	16	220	25	25	3000	8.4	8.4	1037.4	5906675233727
	R-XPT-16250/130	16	250	25	25	3000	9.3	9.3	1148.1	5906675312170
	R-XPT-16280/160	16	280	15	15	1200	6.3	6.3	532.3	5906675250427
	R-XPT-16300/180	16	300	10	10	650	4.4	4.4	318.5	5906675312187
M20	R-XPT-20125/5	20	125	25	25	3000	8.3	8.3	1020.0	5906675233734
	R-XPT-20160/20	20	160	25	25	2000	10.1	10.1	836.0	5906675233741
	R-XPT-20200/60	20	200	10	10	1200	4.9	4.9	619.7	5906675233758
	R-XPT-20250/110	20	250	10	10	1200	5.0	5.0	630.0	5906675312194
	R-XPT-20300/160	20	300	10	10	800	7.1	7.1	593.7	5906675233765
M24	R-XPT-24180/20*	24	180	10	10	1200	7.0	7.0	872.2	5906675233772
	R-XPT-24260/100*	24	260	10	10	1200	9.3	9.3	1148.8	5906675233789
	R-XPT-24300/140*	24	300	10	10	800	10.5	10.5	872.7	5906675233796

* AT-15-9327/2014

R-LX

Self-tapping
concrete screw



STRENGTH OF A SINGLE SCREW

The ring-like structure and the special high-low type thread is a perfect combination of features that enables the thread to bite into the material and develop a reliable and lasting joint. The functioning of our concrete screws is not based on the expansion principle, but they undercut the substrate in order to be able to transfer increased loads. There is more to that, since the design of the screws enables them to efficiently and evenly distribute the forces affecting them over the entire thread. In practice, this means that force distribution in the substrate is analogical to that of elements embedded in concrete. And the effect? Rawlplug's R-LX anchors attain the highest available load capacity compared to other anchors in the class. **STRONG CONNECTION.**

CORROSION PROBLEM – SOLVED

Our solution is so powerful owing to the innovative forging and heat treatment process. Not only does it ensure high steel class in the final product, it also enables multiple use in installation. The process has allowed us to eliminate the risk of what is referred to as hydrogen embrittlement which haunts contractors when they decide to use products made of high hardness carbon steel. Moreover, the R-LX screws have been designed in two variants, and come with high-quality zinc electroplated finish or zinc-flake finish of even higher corrosion resistance. The anticorrosive characteristics of the brand's products have been confirmed in a salt spray chamber test with the result being 1,500 hours! It has ascertained us that the R-LX screws are suitable for certain applications in environments as corrosive as class C4. **100% CERTAINTY OF CORROSION PROTECTION.**

ASTONISHING INSTALLATION SIMPLICITY

Just drill a hole to a diameter slightly smaller than the screw itself by following the clear drill size guidelines provided in the screw product code. A hole thus prepared ensures appropriate screw guiding while its main thread will create precise undercutting of the substrate material as you screw it in. And since this is a one-piece fixing solution, you don't need to use any washers or nuts. Additionally, the screws require no special tools for installation, and even more importantly – they can be completely removed when needed without making any damage. **IT'S SIMPLE.**

EVERY CONTRACTOR'S PROBLEM SOLVED

There is another reason why this product is truly worth your while. The R-LX line is very extensive, encompassing even highly specific requirements and satisfying the needs of professionals from all construction segments. Rawlplug's screws come with as many as 6 different head variations: hexagonal version with integrated washer, countersunk version for flush installation, internally threaded socket version, threaded rod version, cylinder head version and hexagonal version without integrated washer for temporary fixing. Additionally, most of the variants, covers diameters from 5 to 14 mm. **AS YOU NEED IT.**

R-LX



SELF-TAPPING CONCRETE SCREW

The R-LX is an innovative mechanical anchor. The impressive speed and simplicity of installation as well as small edge distance requirements make it unrivalled in many applications. It is exactly what you need to complete a large number of fixings in a short time.



Hexagonal head screw
with washer
R-LX-HF



Countersunk head screw
R-LX-CS



Internally threaded
head screw
R-LX-I



Externally threaded
head screw
R-LX-E



Panhead screw
R-LX-P



Hexagonal head screw
for temporary installation
R-LX-H*

Quick, efficient and secure anchoring



The product is fully supported by **EasyFix** design software



Removal and **multi-functional use**

Main thread's distinctive outline to **maximise the undercut**

Design facilitating transfer of tightening torque to thread

Perfect tip profile **making application easy**



6 screw head variants for **easy adaptation to the piece to be fixed**



Unique and **patented thread profile**

Double thread that ensures **optimum load capacity**





The thread of the R-LX screws bites into the concrete enabling secure transfer of high loads. This allows you to use it without constraints where you were once forced to replace a mechanical anchor with a bonded one. Special thread form and high steel grade allowed this product to top parameters also in seismic class C1 and C2 categories.

RELATED PRODUCT



Testing Gauge allows to determine whether the product R-LX is suitable for re-use.



INSTALLATION GUIDE

You can adjust the screw positioning after fixing.



As confirmed by the European Technical Assessment (ETA) conforming with EAD 330022-00-0601, the screw position can be adjusted twice within a range of up to 1 cm without compromising its load capacity.



Concrete screw **R-LX**

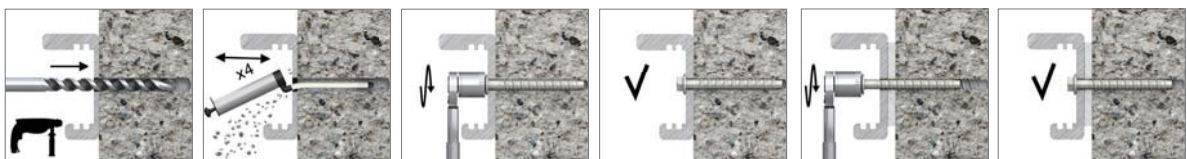

1. Drill a hole to the required diameter and depth.
2. Clean the hole of drilling dust using a brush and a blowpump.
3. Insert a screw into the hole through the fixture and use a torque wrench to tighten it to the required tightening torque.
4. If necessary ease the screw to place a washer, and then tighten it for optimum fixing effect.

R-LX Concrete Screw Anchor

Self-tapping concrete screwbolt



R-LX-HF



R-LX-CS



R-LX-I



R-LX-E
*Make to order



R-LX-P



R-LX-H
*no ETA - For temporary use



ETA-17/0783



ETA-17/0806



C1 - C4



FIRE



SEISMIC C1



SEISMIC C2

Product overview

Features and benefits

- Time-efficient installation through streamlined procedure - simply drill and drive
- Completely removable
- Special zinc flake corrosion-resistant coating
- Unique design with patented threadform ensures high performance for relatively small hole diameter and low torque level during installation
- Non-expansion functioning ensures low risk of damage to base material and makes R-LX ideal for installation near edges and adjacent anchors
- Performance data at two embedment depths (reduced embedment to avoid contact with reinforcement)
- Seismic category C1, C2

Applications

- Through-fixing
- Temporary anchorages
- Formwork supports
- Balustrading & handrails
- Fencing & gates
- Racking systems
- Public seating
- Scaffolding

Base materials

Approved for use in

- Cracked concrete C20/25-C50/60
- Non-cracked concrete C20/25-C50/60
- Hollow core slabs (only R-LX-06)
- Unreinforced concrete
- Reinforced concrete

Installation guide R-LX-HF



1. Drill the hole with rotary percussive machine. Drill to a required depth
2. Blow out dust at least 4 times with a hand pump
3. Possibility of unscrewing and re-screwing
4. Tighten to the recommended torque.
5. After installation.

Installation guide R-LX-CS

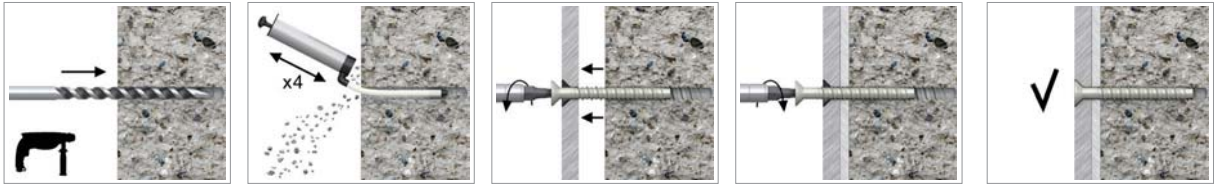

1. Drill the hole with rotary percussive machine. Drill to a required depth
2. Blow out dust at least 4 times with a hand pump
3. Possibility of unscrewing and re-screwing
4. Tighten to the recommended torque
5. After installation.

Installation guide R-LX-I



1. Drill the hole with rotary percussive machine. Drill to a required depth
2. Blow out dust at least 4 times with a hand pump
3. Possibility of unscrewing and re-screwing
4. Tighten to the recommended torque
5. After installation.

Installation guide R-LX-E



1. Drill the hole with rotary percussive machine. Drill to a required depth
2. Blow out dust at least 4 times with a hand pump
3. Possibility of unscrewing and re-screwing
4. Tighten to the recommended torque
5. After installation.

Installation guide R-LX-P



1. Drill the hole with rotary percussive machine. Drill to a required depth
2. Blow out dust at least 4 times with a hand pump
3. Tighten to the recommended torque
4. After installation.

Installation guide R-LX-H



1. Drill the hole with rotary percussive machine. Drill to a required depth
2. Blow out dust at least 4 times with a hand pump
3. Possibility of unscrewing and re-screwing
4. Tighten to the recommended torque
5. After installation.

Product information

R-LX-HF

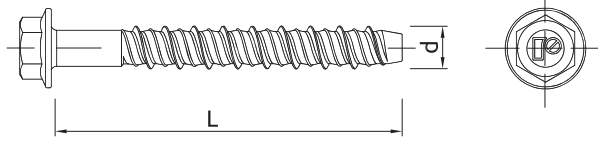

R-LX-E

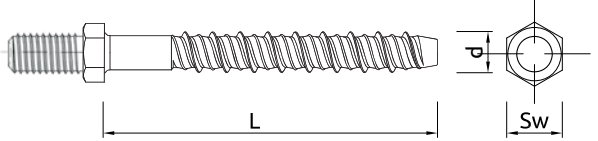

R-LX-CS

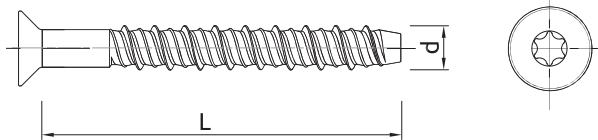

R-LX-I

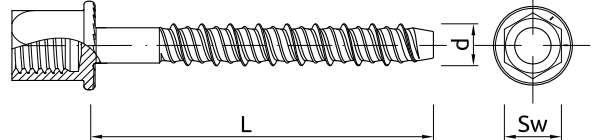

R-LX-P

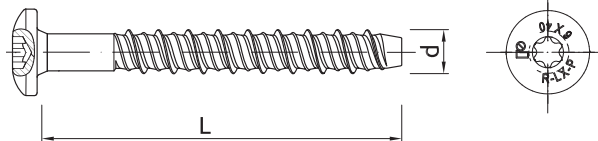

R-LX-H

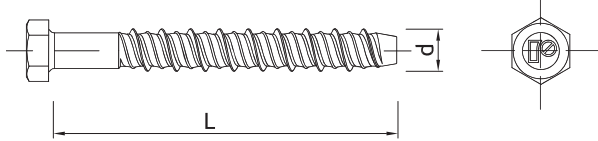

*no ETA - for temporary use

Size	Product Code	Drill	Anchor		Fixture		
			Diameter	Length	Max. thickness		Hole diameter
			d [mm]	L [mm]	t _{fix,r} [mm]	t _{fix,s} [mm]	d _f [mm]
R-LX-HF Hex with Flange Concrete Screw Anchor							
Ø6,3	R-LX-05X050-HF-ZP/R-LX-05X050-HF-ZF	5.0	6.3	50	25	10	7
	R-LX-05X075-HF-ZP/R-LX-05X075-HF-ZF	5.0	6.3	75	50	35	7
Ø7,5	R-LX-06X035-HF-ZP	6.0	7.5	35			9
	R-LX-06X040-HF-ZP	6.0	7.5	40			9
	R-LX-06X050-HF-ZP/R-LX-06X050-HF-ZF	6.0	7.5	50	10	-	9
	R-LX-06X075-HF-ZP/R-LX-06X075-HF-ZF	6.0	7.5	75	35	20	9
	R-LX-06X100-HF-ZP/R-LX-06X100-HF-ZF	6.0	7.5	100	60	45	9
	R-LX-06X130-HF-ZP/R-LX-06X130-HF-ZF	6.0	7.5	130	90	75	9
Ø10	R-LX-06X150-HF-ZP/R-LX-06X150-HF-ZF	6.0	7.5	150	110	95	9
	R-LX-08X060-HF-ZP/R-LX-08X060-HF-ZF	8.0	10	60	10	-	12
	R-LX-08X075-HF-ZP/R-LX-08X075-HF-ZF	8.0	10	75	25	5	12
	R-LX-08X090-HF-ZP/R-LX-08X090-HF-ZF	8.0	10	90	40	20	12
	R-LX-08X100-HF-ZP/R-LX-08X100-HF-ZF	8.0	10	100	50	30	12
	R-LX-08X130-HF-ZP/R-LX-08X130-HF-ZF	8.0	10	130	80	60	12
Ø12,5	R-LX-08X150-HF-ZP/R-LX-08X150-HF-ZF	8.0	10	150	100	80	12
	R-LX-10X065-HF-ZP/R-LX-10X065-HF-ZF	10.0	12.5	65	10	-	14
	R-LX-10X075-HF-ZP/R-LX-10X075-HF-ZF	10.0	12.5	75	20	-	14
	R-LX-10X085-HF-ZP/R-LX-10X085-HF-ZF	10.0	12.5	85	30	-	14
	R-LX-10X100-HF-ZP/R-LX-10X100-HF-ZF	10.0	12.5	100	45	15	14
	R-LX-10X120-HF-ZP/R-LX-10X120-HF-ZF	10.0	12.5	120	65	35	14
Ø14,9*	R-LX-10X140-HF-ZP/R-LX-10X140-HF-ZF	10.0	12.5	140	85	55	14
	R-LX-12X075-HF-ZP/R-LX-12X075-HF-ZF	12.0	14.9	75	10	-	16
	R-LX-12X100-HF-ZP/R-LX-12X100-HF-ZF	12.0	14.9	100	35	-	16
	R-LX-12X130-HF-ZP/R-LX-12X130-HF-ZF	12.0	14.9	130	65	30	16
Ø17	R-LX-12X150-HF-ZP/R-LX-12X150-HF-ZF	12.0	14.9	150	85	50	16
	R-LX-14X080-HF-ZP/R-LX-14X080-HF-ZF	14.0	17	80	5	-	18
	R-LX-14X105-HF-ZP/R-LX-14X105-HF-ZF	14.0	17	105	30	-	18
	R-LX-14X115-HF-ZP/R-LX-14X115-HF-ZF	14.0	17	115	40	-	18
	R-LX-14X135-HF-ZP/R-LX-14X135-HF-ZF	14.0	17	135	60	15	18

* not included in the approval

All products listed in this publication are branded and distributed with RAWLPLUG® or RAWL® trademarks.

Product information (cont.)

Size	Product Code	Drill	Anchor		Fixture		
			Diameter	Length	Max. thickness		Hole diameter
			d	L	t _{fix, r}	t _{fix, s}	d _f
			[mm]	[mm]	[mm]	[mm]	[mm]
R-LX-CS Countersunk Concrete Screw Anchor							
Ø6,3	R-LX-05X050-CS-ZP/R-LX-05X050-CS-ZF	5.0	6.3	50	-	7	7
	R-LX-05X075-CS-ZP/R-LX-05X075-CS-ZF	5.0	6.3	75	-	32	7
Ø7,5	R-LX-06X050-CS-ZP/R-LX-06X050-CS-ZF	6.0	7.5	50	7	-	9
	R-LX-06X075-CS-ZP/R-LX-06X075-CS-ZF	6.0	7.5	75	32	20	9
	R-LX-06X100-CS-ZP/R-LX-06X100-CS-ZF	6.0	7.5	100	57	45	9
	R-LX-06X130-CS-ZP/R-LX-06X130-CS-ZF	6.0	7.5	130	87	75	9
	R-LX-06X150-CS-ZP/R-LX-06X150-CS-ZF	6.0	7.5	150	107	95	9
Ø10	R-LX-08X060-CS-ZP/R-LX-08X060-CS-ZF	8.0	10	60	10	-	12
	R-LX-08X075-CS-ZP/R-LX-08X075-CS-ZF	8.0	10	75	25	5	12
	R-LX-08X090-CS-ZP/R-LX-08X090-CS-ZF	8.0	10	90	40	20	12
	R-LX-08X100-CS-ZP/R-LX-08X100-CS-ZF	8.0	10	100	50	30	12
	R-LX-08X130-CS-ZP/R-LX-08X130-CS-ZF	8.0	10	130	80	60	12
	R-LX-08X150-CS-ZP/R-LX-08X150-CS-ZF	8.0	10	150	100	80	12
Ø12,5	R-LX-10X065-CS-ZP/R-LX-10X065-CS-ZF	10.0	12.5	65	10	-	14
	R-LX-10X075-CS-ZP/R-LX-10X075-CS-ZF	10.0	12.5	75	20	-	14
	R-LX-10X085-CS-ZP/R-LX-10X085-CS-ZF	10.0	12.5	85	30	-	14
	R-LX-10X100-CS-ZP/R-LX-10X100-CS-ZF	10.0	12.5	100	45	15	14
	R-LX-10X120-CS-ZP/R-LX-10X120-CS-ZF	10.0	12.5	120	65	35	14
	R-LX-10X140-CS-ZP/R-LX-10X140-CS-ZF	10.0	12.5	140	85	55	14
	R-LX-10X160-CS-ZP/R-LX-10X160-CS-ZF	10.0	12.5	160	105	75	14
R-LX-I Internally threaded head screw							
Ø7,5	R-LX-06X035-I06-ZP	6.0	7.5	35	-	-	-
	R-LX-06X035-I08-ZP	6.0	7.5	35	-	-	-
	R-LX-06X035-I10-ZP	6.0	7.5	35	-	-	-
	R-LX-06X055-I08-ZP	6.0	7.5	55	-	-	-
	R-LX-06X055-I10-ZP	6.0	7.5	55	-	-	-
R-LX-P Panhead head screw							
Ø7,5	R-LX-06X040-P-ZP	6.0	7.5	40	1	-	9
R-LX-H Hex Concrete Screw Anchor							
Ø10	R-LX-10X060-H-ZP/R-LX-10X060-H-ZF	8.0	10.0	60	10	-	12
	R-LX-10X075-H-ZP/R-LX-10X075-H-ZF	8.0	10.0	75	25	5	12
	R-LX-10X090-H-ZP/R-LX-10X090-H-ZF	8.0	10.0	90	40	20	12
	R-LX-10X100-H-ZP/R-LX-10X100-H-ZF	8.0	10.0	100	50	30	12
	R-LX-10X130-H-ZP/R-LX-10X130-H-ZF	8.0	10.0	130	80	60	12
	R-LX-10X150-H-ZP/R-LX-10X150-H-ZF	8.0	10.0	150	100	80	12
Ø12,5	R-LX-14X065-H-ZP/R-LX-14X065-H-ZF	10.0	12.5	65	10	-	17
	R-LX-14X075-H-ZP/R-LX-14X075-H-ZF	10.0	12.5	75	20	-	17
	R-LX-14X085-H-ZP/R-LX-14X085-H-ZF	10.0	12.5	85	30	-	17
	R-LX-14X100-H-ZP/R-LX-14X100-H-ZF	10.0	12.5	100	45	15	17
	R-LX-14X120-H-ZP/R-LX-14X120-H-ZF	10.0	12.5	120	65	35	17
	R-LX-14X140-H-ZP/R-LX-14X140-H-ZF	10.0	12.5	140	85	55	17

* not included in the approval

Installation data

Installation data - concrete

Size			R-LX-05	R-LX-06	R-LX-08	R-LX-10	R-LX-14
Thread diameter	d	[mm]	6,3	7,5	10	12,5	17,0
Hole diameter in substrate	d ₀	[mm]	5	6	8	10	14
Min. spacing	s _{min,s}	[mm]	40	45	50	60	100
Min. edge distance	c _{min,s}	[mm]	40	45	50	60	100
STANDARD EMBEDMENT DEPTH							
Min. hole depth in substrate	h _{0,s}	[mm]	50	65	80	95	130
Installation depth	h _{nom,s}	[mm]	43/40**	55	70	85	120
Min. substrate thickness	h _{min,s}	[mm]	100/80**	100/84**	110	130	190
REDUCED EMBEDMENT DEPTH							
Min. hole depth in substrate	h _{0,r}	[mm]	35**	50/45**	60	65	85
Installation depth	h _{nom,r}	[mm]	25**	43/39*/35**	50	55	75
Min. substrate thickness	h _{min,r}	[mm]	80**		100/80**		110

* for R-LX-I and R-LX-E

**for non-structural applications

Installation data - płyty kanałowe **

Size			R-LX-06
Thread diameter	d	[mm]	7,5
Hole diameter in substrate	d ₀	[mm]	6
Min. spacing	s _{min,s}	[mm]	100
Min. edge distance	c _{min,s}	[mm]	100
STANDARD EMBEDMENT DEPTH			
Min. hole depth in substrate	h _{0,s}	[mm]	45
Installation depth	h _{nom,s}	[mm]	35
Core width / Web thickness	w/e	-	≤ 4,2
Core distance	lc	[mm]	≥ 100
Prestressing steel	lp	[mm]	≥ 100
Distance between anchor position and prestressing steel	ap	[mm]	≥ 50

**for non-structural applications

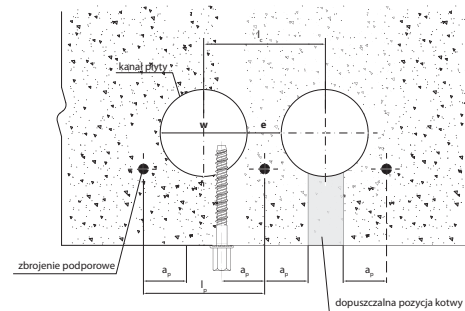

Mechanical properties

Size			5	6	8	10	14
Nominal ultimate tensile strength - tension	f _{uk}	[N/mm ²]	1300	1250	1200	1050	1020
Nominal yield strength - tension	f _{yk}	[N/mm ²]	1150	1100	1050	950	800
Cross sectional area - tension	A _s	[mm ²]	19.6	28.3	50.3	78.5	153.9
Elastic section modulus	W _{el}	[mm ³]	12.2	21.2	50.3	98.1	269.3
Characteristic bending resistance	M ⁰ _{Rk,s}	[Nm]	19.0	31.8	72.4	123.6	329.6
Design bending resistance	M	[Nm]	12.67	21.2	48.27	82.4	219.73

Basic performance data

Performance data for single anchor without influence of edge distance and spacing

Size		Ø5	Ø6	Ø8	Ø10	Ø14
CHARACTERISTIC LOAD						
TENSION LOAD $N_{R,u,m}$						
NON-CRACKED CONCRETE C20/25						
Standard embedment depth	[kN]	7.00	12.00	19.49	26.46	44.56
Reduced embedment depth	[kN]	-	9.14	10.91	12.78	20.04
CRACKED CONCRETE C20/25						
Standard embedment depth	[kN]	4.50	7.00	13.00	18.87	31.77
Reduced embedment depth	[kN]	-	6.52	7.50	8.00	13.00
SHEAR LOAD $N_{R,u,m}$						
NON-CRACKED CONCRETE C20/25						
Standard embedment depth	[kN]	9.14	13.75	19.49	41.20	78.50
Reduced embedment depth	[kN]	-	9.14	10.91	12.78	20.04
CRACKED CONCRETE C20/25						
Standard embedment depth	[kN]	6.52	9.80	13.89	37.73	63.54
Reduced embedment depth	[kN]	-	6.52	7.78	9.11	14.29
DESIGN LOAD						
TENSION LOAD $N_{R,u,m}$						
NON-CRACKED CONCRETE C20/25						
Standard embedment depth	[kN]	3.89	8.00	12.99	17.64	29.71
Reduced embedment depth	[kN]	-	6.09	7.27	8.52	13.36
CRACKED CONCRETE C20/25						
Standard embedment depth	[kN]	2.50	4.67	8.67	12.58	21.18
Reduced embedment depth	[kN]	-	4.34	5.00	5.33	8.67
SHEAR LOAD $N_{R,u,m}$						
NON-CRACKED CONCRETE C20/25						
Standard embedment depth	[kN]	6.09	9.16	12.99	27.47	52.33
Reduced embedment depth	[kN]	-	6.09	7.27	8.52	13.36
CRACKED CONCRETE C20/25						
Standard embedment depth	[kN]	4.34	6.53	9.26	25.15	42.36
Reduced embedment depth	[kN]	-	4.34	5.18	6.07	9.52
RECOMMENDED LOAD						
TENSION LOAD $N_{R,u,m}$						
NON-CRACKED CONCRETE C20/25						
Standard embedment depth	[kN]	2.78	5.71	9.28	12.60	21.22
Reduced embedment depth	[kN]	-	4.35	5.19	6.08	9.54
CRACKED CONCRETE C20/25						
Standard embedment depth	[kN]	1.79	3.33	6.19	8.98	15.13
Reduced embedment depth	[kN]	-	3.10	3.57	3.81	6.19
SHEAR LOAD $N_{R,u,m}$						
NON-CRACKED CONCRETE C20/25						
Standard embedment depth	[kN]	4.35	6.55	9.28	19.62	37.38
Reduced embedment depth	[kN]	-	4.35	5.19	6.08	9.54
CRACKED CONCRETE C20/25						
Standard embedment depth	[kN]	3.10	4.67	6.61	17.97	30.25
Reduced embedment depth	[kN]	-	3.10	3.70	4.34	6.80

Product Commercial Data

Size	Product Code		Anchor		Quantity [pcs]	Bar Code	
			Diameter	Length	Box		
			d	L			
			[mm]				
R-LX-HF Hex with Flange Concrete Screw Anchor						R-LX-HF-ZP	R-LX-HF-ZF
Ø6,3	R-LX-05X050-HF-ZP	R-LX-05X050-HF-ZF	6.3	50	100	5906675112947	5906675129570
	R-LX-05X075-HF-ZP	R-LX-05X075-HF-ZF	6.3	75	100	5906675112961	5906675129587
Ø7,5	R-LX-06X035-HF-ZP	-	7.5	35	100	5906675391083	-
	R-LX-06X040-HF-ZP	-	7.5	40	100	5906675391090	-
	R-LX-06X050-HF-ZP	R-LX-06X050-HF-ZF	7.5	50	100	5906675112978	5906675129594
	R-LX-06X075-HF-ZP	R-LX-06X075-HF-ZF	7.5	75	100	5906675119175	5906675129600
	R-LX-06X100-HF-ZP	R-LX-06X100-HF-ZF	7.5	100	100	5906675119182	5906675129617
	R-LX-06X130-HF-ZP	R-LX-06X130-HF-ZF	7.5	130	100	5906675119199	5906675129624
	R-LX-06X150-HF-ZP	R-LX-06X150-HF-ZF	7.5	150	100	5906675119205	5906675129631
Ø10	R-LX-08X060-HF-ZP	R-LX-08X060-HF-ZF	10	60	100	5906675119212	5906675129648
	R-LX-08X075-HF-ZP	R-LX-08X075-HF-ZF	10	75	100	5906675119236	5906675129655
	R-LX-08X090-HF-ZP	R-LX-08X090-HF-ZF	10	90	100	5906675119243	5906675129662
	R-LX-08X100-HF-ZP	R-LX-08X100-HF-ZF	10	100	100	5906675119250	5906675129679
	R-LX-08X130-HF-ZP	R-LX-08X130-HF-ZF	10	130	50	5906675119267	5906675129686
	R-LX-08X150-HF-ZP	R-LX-08X150-HF-ZF	10	150	50	5906675119274	5906675129693
Ø12,5	R-LX-10X065-HF-ZP	R-LX-10X065-HF-ZF	12.5	65	50	5906675119281	5906675129709
	R-LX-10X075-HF-ZP	R-LX-10X075-HF-ZF	12.5	75	50	5906675119304	5906675129716
	R-LX-10X085-HF-ZP	R-LX-10X085-HF-ZF	12.5	85	50	5906675119311	5906675129723
	R-LX-10X100-HF-ZP	R-LX-10X100-HF-ZF	12.5	100	50	5906675119335	5906675129730
	R-LX-10X120-HF-ZP	R-LX-10X120-HF-ZF	12.5	120	25	5906675119342	5906675129747
Ø14	R-LX-10X140-HF-ZP	R-LX-10X140-HF-ZF	12.5	140	25	5906675119410	5906675129754
	R-LX-12X075-HF-ZP*	R-LX-12X075-HF-ZF*	14.9	75	50	5906675119489	5906675129761
	R-LX-12X100-HF-ZP*	R-LX-12X100-HF-ZF*	14.9	100	50	5906675431901	5906675431932
	R-LX-12X130-HF-ZP*	R-LX-12X130-HF-ZF*	14.9	130	50	5906675431918	5906675431949
Ø17	R-LX-12X150-HF-ZP*	R-LX-12X150-HF-ZF*	14.9	150	50	5906675423746	5906675423753
	R-LX-14X080-HF-ZP	R-LX-14X080-HF-ZF	17	80	20	5906675119946	5906675129822
	R-LX-14X105-HF-ZP	R-LX-14X105-HF-ZF	17	105	20	5906675119953	5906675129839
	R-LX-14X115-HF-ZP	R-LX-14X115-HF-ZF	17	115	20	5906675119960	5906675129846
	R-LX-14X135-HF-ZP	R-LX-14X135-HF-ZF	17	135	20	5906675119977	5906675129853
R-LX-CS Countersunk Concrete Screw Anchor						R-LX-CS-ZP	R-LX-CS-ZF
Ø6,3	R-LX-05X050-CS-ZP	R-LX-05X050-CS-ZF	6.3	50	-	5906675127859	5906675130217
	R-LX-05X075-CS-ZP	R-LX-05X075-CS-ZF	6.3	75	-	5906675128054	5906675130224
Ø7,5	R-LX-06X050-CS-ZP	R-LX-06X050-CS-ZF	7.5	50	100	5906675128801	5906675130231
	R-LX-06X075-CS-ZP	R-LX-06X075-CS-ZF	7.5	75	100	5906675129280	5906675130248
	R-LX-06X100-CS-ZP	R-LX-06X100-CS-ZF	7.5	100	100	5906675129297	5906675130255
	R-LX-06X130-CS-ZP	R-LX-06X130-CS-ZF	7.5	130	100	5906675129303	5906675130262
	R-LX-06X150-CS-ZP	R-LX-06X150-CS-ZF	7.5	150	100	5906675129310	5906675130279
Ø10	R-LX-08X060-CS-ZP	R-LX-08X060-CS-ZF	10	60	100	5906675129327	5906675130385
	R-LX-08X075-CS-ZP	R-LX-08X075-CS-ZF	10	75	100	5906675129334	5906675130392
	R-LX-08X090-CS-ZP	R-LX-08X090-CS-ZF	10	90	100	5906675129341	5906675130408
	R-LX-08X100-CS-ZP	R-LX-08X100-CS-ZF	10	100	100	5906675129358	5906675130415
	R-LX-08X130-CS-ZP	R-LX-08X130-CS-ZF	10	130	50	5906675129365	5906675130422
	R-LX-08X150-CS-ZP	R-LX-08X150-CS-ZF	10	150	50	5906675129372	5906675130439
Ø12,5	R-LX-10X065-CS-ZP	R-LX-10X065-CS-ZF	12.5	65	50	5906675129389	5906675130453
	R-LX-10X075-CS-ZP	R-LX-10X075-CS-ZF	12.5	75	50	5906675129396	5906675130460
	R-LX-10X085-CS-ZP	R-LX-10X085-CS-ZF	12.5	85	50	5906675129402	5906675130477
	R-LX-10X100-CS-ZP	R-LX-10X100-CS-ZF	12.5	100	50	5906675129419	5906675130491
	R-LX-10X120-CS-ZP	R-LX-10X120-CS-ZF	12.5	120	25	5906675129426	5906675130514
	R-LX-10X140-CS-ZP	R-LX-10X140-CS-ZF	12.5	140	25	5906675129433	5906675130521
	R-LX-10X160-CS-ZP	R-LX-10X160-CS-ZF	12.5	160	20	5906675129440	5906675130538

Product Commercial Data

Size	Product Code	Anchor		Quantity [pcs]	Bar Code		
		Diameter	Length	Box			
		d	L				
		[mm]					
R-LX-P Panhead head screw					R-LX-P-ZP		
Ø7.5	R-LX-06X040-P-ZP	7.5	40	100	5906675034546		
R-LX-I Internally threaded head screw					R-LX-I-ZP		
Ø6	R-LX-06X035-I06-ZP	7.5	35	100	5906675430836		
	R-LX-06X035-I08-ZP	7.5	35	100	5906675416069		
	R-LX-06X035-I10-ZP	7.5	35	100	5906675416076		
	R-LX-06X055-I08-ZP	7.5	55	100	5906675416083		
	R-LX-06X055-I10-ZP	7.5	55	100	5906675416090		
R-LX-H Hex Concrete Screw Anchor					R-LX-H-ZP	R-LX-H-ZF	
Ø10	*R-LX-08X060-H-ZP	*R-LX-08X060-H-ZF	10	60	100	5906675120768	5906675129969
	*R-LX-08X075-H-ZP	*R-LX-08X075-H-ZF	10	75	100	5906675120812	5906675129976
	*R-LX-08X090-H-ZP	*R-LX-08X090-H-ZF	10	90	100	5906675120843	5906675129983
	*R-LX-08X100-H-ZP	*R-LX-08X100-H-ZF	10	100	100	5906675121055	5906675129990
	*R-LX-08X130-H-ZP	*R-LX-08X130-H-ZF	10	130	50	5906675121185	5906675130002
	*R-LX-08X150-H-ZP	*R-LX-08X150-H-ZF	10	150	50	5906675121192	5906675130019
Ø12,5	*R-LX-10X065-H-ZP	*R-LX-10X065-H-ZF	12,5	65	50	5906675121208	5906675130026
	*R-LX-10X075-H-ZP	*R-LX-10X075-H-ZF	12,5	75	50	5906675121482	5906675130033
	*R-LX-10X085-H-ZP	*R-LX-10X085-H-ZF	12,5	85	50	5906675122076	5906675130040
	*R-LX-10X100-H-ZP	*R-LX-10X100-H-ZF	12,5	100	50	5906675122557	5906675130057
	*R-LX-10X120-H-ZP	*R-LX-10X120-H-ZF	12,5	120	25	5906675123141	5906675130064
	*R-LX-10X140-H-ZP	*R-LX-10X140-H-ZF	12,5	140	25	5906675123615	5906675130071
Ø17	*R-LX-14X105-H-ZP	*R-LX-14X105-H-ZF	17,0	105	20	5906675127521	5906675130156
	*R-LX-14X135-H-ZP	*R-LX-14X135-H-ZF	17,0	135	20	5906675127545	5906675130170

SHIELD ANCHORS

RAWLBOLT™:

- R-RBL
 - Loose Bolt
- R-RBP
 - Bolt Projecting
- R-RBL-PF Colar
- R-RBP-PF Colar
- R-RBL-E
 - Eye Bolt
- R-RBL-H
 - Hook Bolt
- R-RB
 - Rawlbolt Shield

Optimum taper nut angle for maximum expansion in all substrates



Bolt lengths suitable for fixture thickness up to 150mm

Shield available separately

Pressed steel segments ensure consistent dimensional accuracy

R-RBL, R-RBP Rawlbolt for use in cracked and non-cracked concrete

World's most popular all-purpose expanding shield anchor



Approvals and Reports

- ETA-11/0479



Versions

- R-RBL - Loose Bolt
- R-RBP - Bolt Projecting



Installation movie

Product overview

Features and benefits

- RAWLBOLT® - first ever mechanical anchor in the world, forerunner of all of the later mechanical anchors
- For use in cracked and non-cracked concrete (ETA option 1), hollow-core slabs, flooring blocks and ceramics
- Product recommended for applications requiring fire resistance up to 120 min
- Three-piece expanding sleeve provides maximum expansion to ensure optimum loads and safety are achieved in various substrates
- Wide range of diameters (M6 to M24)

Applications

- Roller shutter doors
- Fire doors
- Steelwork
- Security grills
- Machinery
- Pipework/ductwork supports

Base materials

Approved for use in:

- Cracked concrete C20/25-C50/60
- Non-cracked concrete C20/25-C50/60
- Unreinforced concrete
- Reinforced concrete

Installation guide



Installation guide (cont.)



1. Drill a hole of required diameter and depth
2. Clear the hole of drilling dust and debris (using blow pump and brush or equivalent method)
3. Remove pre-assembled bolt and washer. Insert shield into hole and tap home with hammer until flush with surface
4. Insert bolt with washer through fixture into the shield
5. Tighten to the recommended torque

Product information

R-RBL

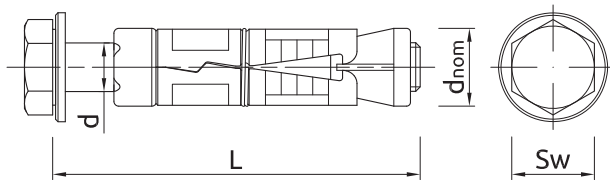

Size	Product Code	Anchor			Fixture	
		Bolt diameter	External diameter	Bolt length	Max. thickness	Hole diameter
		d	d _{nom}	L	t _{fix}	d _f
		[mm]	[mm]	[mm]	[mm]	[mm]
M6	R-RBL-M06/10W	6	12	55	10	6.5
	R-RBL-M06/25W	6	12	70	25	6.5
	R-RBL-M06/40W	6	12	85	40	6.5
M8	R-RBL-M08/10W	8	14	65	10	9
	R-RBL-M08/25W	8	14	80	25	9
	R-RBL-M08/40W	8	14	95	40	9
M10	R-RBL-M10/10W	10	16	75	10	11
	R-RBL-M10/25W	10	16	90	25	11
	R-RBL-M10/50W	10	16	115	50	11
	R-RBL-M10/75W	10	16	140	75	11
M12	R-RBL-M12/10W	12	20	90	10	13
	R-RBL-M12/25W	12	20	105	25	13
	R-RBL-M12/40W	12	20	120	40	13
	R-RBL-M12/60W	12	20	140	60	13
M16	R-RBL-M16/15W	16	25	135	15	17
	R-RBL-M16/30W	16	25	150	30	17
	R-RBL-M16/60W	16	25	180	60	17
M20	R-RBL-M20/60W	20	32	195	60	22
	R-RBL-M20/100W	20	32	235	110	22
M24*	R-RBL-M24/100W	24	38	255	100	26
	R-RBL-M24/150W	24	38	300	150	26

*M24 not included in the approval

Product information (cont.)

R-RBP

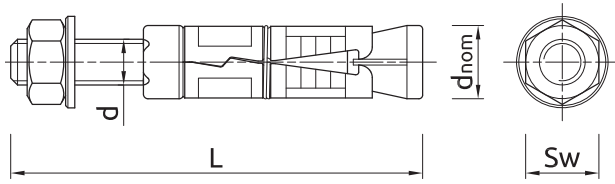

Size	Product Code	Anchor			Fixture	
		Bolt diameter	External diameter	Length	Max. thickness	Hole diameter
		d	d _{nom}	L	t _{fix}	d _f
		[mm]	[mm]	[mm]	[mm]	[mm]
M6	R-RBP-M06/10W	6	12	65	10	6.5
	R-RBP-M06/25W	6	12	80	25	6.5
	R-RBP-M06/60W	6	12	115	60	6.5
M8	R-RBP-M08/10W	8	14	75	10	9
	R-RBP-M08/25W	8	14	90	25	9
	R-RBP-M08/60W	8	14	125	60	9
M10	R-RBP-M10/15W	10	16	90	15	11
	R-RBP-M10/30W	10	16	105	30	11
	R-RBP-M10/60W	10	16	135	60	11
M12	R-RBP-M12/15W	12	20	110	15	13
	R-RBP-M12/30W	12	20	125	30	13
	R-RBP-M12/75W	12	20	170	75	13
M16	R-RBP-M16/15W	16	25	150	15	17
	R-RBP-M16/35W	16	25	170	35	17
	R-RBP-M16/75W	16	25	210	75	17
M20	R-RBP-M20/15W	20	32	170	15	22
	R-RBP-M20/30W	20	32	185	30	22
	R-RBP-M20/100W	20	32	255	100	22
M24*	R-RBP-M24/75W	24	38	255	75	26
	R-RBP-M24/150W	24	38	300	150	26

*M24 not included in the approval

Installation data

R-RBL

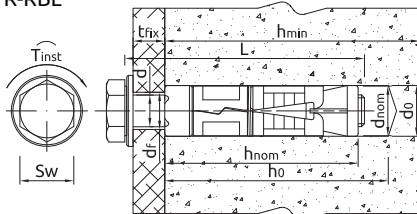

R-RBP

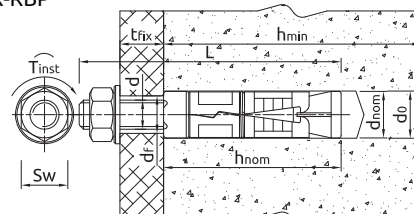

Size			M6	M8	M10	M12	M16	M20	M24
Thread diameter	d	[mm]	6	8	10	12	16	20	24
Hole diameter in substrate	d _o	[mm]	12	14	16	20	25	32	38
Installation torque	T _{inst}	[Nm]	6.5	15	27	50	120	230	400
Min. hole depth in substrate	h _o	[mm]	50	55	65	85	125	140	160
Installation depth	h _{nom}	[mm]	45	50	60	80	120	135	155
Min. substrate thickness	h _{min}	[mm]	100				142.5	172.5	240
Min. spacing	s _{min}	[mm]	35	40	50	60	95	115	210
Min. edge distance	c _{min}	[mm]	53	60	75	90	143	173	188

Mechanical properties

Size			M6	M8	M10	M12	M16	M20	M24
Nominal ultimate tensile strength - tension	f_{uk}	[N/mm ²]	500	500	500	500	500	500	500
Nominal yield strength - tension	f_{yk}	[N/mm ²]	400	400	400	400	400	400	400
Cross sectional area - tension	A_s	[mm ²]	20.1	36.6	58.0	84.3	157.0	245.0	353.0
Elastic section modulus	W_{el}	[mm ³]	21.21	50.27	98.17	169.65	402.12	785.4	1357.17
Characteristic bending resistance	$M^0_{Rk,s}$	[Nm]	12.72	30.16	58.9	101.79	241.27	471.24	814.3
Design bending resistance	M	[Nm]	10.18	24.13	47.12	81.43	193.02	376.99	651.44

Basic performance data

Performance data for single anchor without influence of edge distance and spacing

Size		M6	M8	M10	M12	M16	M20	M24
Embedment depth h_{ef}	[mm]	35	40	50	60	95	115	125
CHARACTERISTIC LOAD								
TENSION LOAD N_{Rk}								
NON-CRACKED CONCRETE	[kN]	6.00	7.50	12.00	16.00	40.00	50.00	70.00
CRACKED CONCRETE	[kN]	4.00	5.00	6.00	12.00	16.00	30.00	-
SHEAR LOAD V_{Rk}								
NON-CRACKED CONCRETE	[kN]	5.03	9.15	14.50	21.08	39.25	61.25	88.3
CRACKED CONCRETE	[kN]	5.03	9.11	12.73	21.08	39.25	61.25	-
DESIGN LOAD								
TENSION LOAD N_{Rd}								
NON-CRACKED CONCRETE	[kN]	3.33	4.17	6.67	8.89	22.22	27.78	38.90
CRACKED CONCRETE	[kN]	2.22	2.78	3.33	6.67	8.89	16.67	-
SHEAR LOAD V_{Rd}								
NON-CRACKED CONCRETE	[kN]	4.02	7.32	11.60	16.86	31.40	49.00	70.60
CRACKED CONCRETE	[kN]	4.02	7.32	10.61	16.86	31.40	49.00	-
RECOMMENDED LOAD								
TENSION LOAD N_{rec}								
NON-CRACKED CONCRETE	[kN]	2.38	2.98	4.76	6.35	15.87	19.84	27.80
CRACKED CONCRETE	[kN]	1.59	1.99	2.38	4.76	6.35	11.91	-
SHEAR LOAD V_{rec}								
NON-CRACKED CONCRETE	[kN]	2.87	5.23	8.29	12.05	22.43	35.00	50.40
CRACKED CONCRETE	[kN]	2.87	5.23	7.58	12.05	22.43	35.00	-

Product commercial data

Size	Product Code	Anchor		Quantity [pcs]			Weight [kg]			Bar Code
		Diameter [mm]	Length [mm]	Box	Outer	Pallet	Box	Outer	Pallet	
Rawlbolt R-RBL Loose Bolt										
M6	R-RBL-M06/10W	6	55	50	400	16000	1.56	12.4	527.6	5906675283210
	R-RBL-M06/25W	6	70	50	50	16000	1.65	13.2	556.4	5906675283234
	R-RBL-M06/40W	6	85	50	50	8000	1.81	1.81	319.6	5906675283258
M8	R-RBL-M08/10W	8	65	50	50	16000	2.7	21.6	895.6	5906675283272
	R-RBL-M08/25W	8	80	50	50	8000	3.0	3.0	502.0	5906675283296
	R-RBL-M08/40W	8	95	50	50	8000	3.2	3.2	541.2	5906675283319

Product commercial data (cont.)

Size	Product Code	Anchor		Quantity [pcs]			Weight [kg]			Bar Code
		Diameter [mm]	Length [mm]	Box	Outer	Pallet	Box	Outer	Pallet	
M10	R-RBL-M10/10W	10	75	50	50	8000	4.6	4.6	765.2	5906675283333
	R-RBL-M10/25W	10	90	50	50	8000	5.0	5.0	832.4	5906675283357
	R-RBL-M10/50W	10	115	50	50	6000	5.6	5.6	705.6	5906675283371
	R-RBL-M10/75W	10	140	50	50	8000	6.4	6.4	1054.0	5906675283395
M12	R-RBL-M12/10W	12	90	25	25	4000	4.2	4.2	700.4	5906675283401
	R-RBL-M12/25W	12	105	25	25	4000	4.5	4.5	749.6	5906675283418
	R-RBL-M12/40W	12	120	25	25	3000	4.9	4.9	614.7	5906675283425
	R-RBL-M12/60W	12	140	25	25	4000	5.2	5.2	862.0	5906675283432
M16	R-RBL-M16/15W	16	135	10	10	1600	4.2	4.2	693.5	5906675283449
	R-RBL-M16/30W	16	150	10	10	1600	4.4	4.4	734.3	5906675283456
	R-RBL-M16/60W	16	180	10	10	1200	4.8	4.8	608.3	5906675283463
M20	R-RBL-M20/60W	20	195	10	10	1200	9.0	9.0	1113.5	5906675283487
	R-RBL-M20/100W	20	235	10	10	1200	9.8	9.8	1207.8	5906675283470
M24*	R-RBL-M24/100W	24	255	5	5	400	7.4	7.4	622.2	5906675283494
	R-RBL-M24/150W	24	300	2	10	400	16.3	16.3	681.5	5906675283500
Rawlbolt R-RBP Bolt Projecting										
M6	R-RBP-M06/10W	6	65	50	400	16000	1.59	12.7	538.8	5906675283593
	R-RBP-M06/25W	6	80	50	400	16000	1.73	13.8	582.0	5906675283616
	R-RBP-M06/60W	6	115	50	50	8000	2.0	2.0	354.0	5906675283630
M8	R-RBP-M08/10W	8	75	50	400	16000	2.9	22.9	946.8	5906675283654
	R-RBP-M08/25W	8	90	50	50	8000	3.1	3.1	528.4	5906675283678
	R-RBP-M08/60W	8	125	50	50	8000	3.7	3.7	614.8	5906675283692
M10	R-RBP-M10/15W	10	90	50	50	8000	5.0	5.0	825.2	5906675283715
	R-RBP-M10/30W	10	105	50	50	6000	5.3	5.3	666.0	5906675283739
	R-RBP-M10/60W	10	135	50	50	8000	6.1	6.1	998.0	5906675283753
M12	R-RBP-M12/15W	12	110	25	25	4000	4.6	4.6	767.2	5906675283760
	R-RBP-M12/30W	12	125	25	25	4000	4.9	4.9	818.4	5906675283777
	R-RBP-M12/75W	12	170	25	25	3000	5.8	5.8	721.8	5906675283784
M16	R-RBP-M16/15W	16	150	10	10	1600	4.4	4.4	733.5	5906675283791
	R-RBP-M16/35W	16	170	10	10	1600	4.7	4.7	773.5	5906675283807
	R-RBP-M16/75W	16	210	10	10	1200	5.3	5.3	662.9	5906675283814
M20	R-RBP-M20/15W	20	170	10	10	1200	8.0	8.0	985.1	5906675283821
	R-RBP-M20/30W	20	185	10	10	1200	8.3	8.3	1030.4	5906675283838
	R-RBP-M20/100W	20	255	10	10	1200	9.9	9.9	1219.2	5906675284781
M24*	R-RBP-M24/75W	24	255	5	5	600	7.1	7.1	887.2	5906675283852
	R-RBP-M24/150W	24	300	2	2	400	3.2	3.2	672.0	5906675283845

*M24 not included in the approval

R-RBL, R-RBP Rawlbolt for use in hollow core slab and ceramic substrates

World's most popular all-purpose expanding shield anchor for use in hollow core slab and ceramic substrates



R-RBL - Loose Bolt



R-RBP - Bolt Projecting



Approvals and Reports

- AT-15-7280/2014



Versions

- R-RBL - Loose Bolt
- R-RBP - Bolt Projecting



Installation movie

Product overview

Features and benefits

- RAWLBOLT® - first ever mechanical anchor in the world, forerunner of all of the later mechanical anchors
- For use in cracked and non-cracked concrete (ETA option 1), hollow-core slabs, flooring blocks and ceramics
- Three-piece expanding sleeve provides maximum expansion to ensure optimum loads and safety are achieved in various substrates
- Wide range of diameters (M6 to M24)

Applications

- Roller shutter doors
- Fire doors
- Steelwork
- Security grills
- Machinery
- Pipework/ductwork supports

Base materials

Approved for use in:

- Solid clay brick ≥ 20 MPa
- Hollow Lightweight Concrete Block LAC 5 ≥ 5 MPa
- Hollow Sand-lime Brick ≥ 15 MPa
- Concrete hollow floor block (eg. Teriva)
- Hollow-core Slab C20/25
- Hollow-core Slab C30/37-C50/60

Installation guide

R-RBL



R-RBP



Installation guide (cont.)

1. Drill a hole of required diameter and depth. Note: When fixing into brickwork, mortar joints should be avoided
2. Clear the hole of drilling dust and debris (using blow pump and brush or equivalent method)
3. Remove pre-assembled bolt and washer. Insert shield into hole and tap home with hammer until flush with surface
4. Insert bolt with washer through fixture into the shield
5. Tighten to the recommended torque

Product information

R-RBL

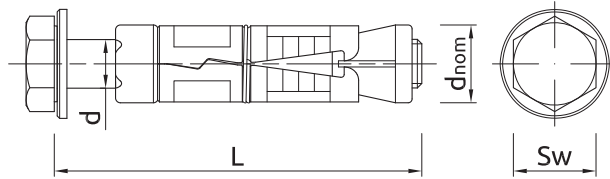

Size	Product Code	Anchor			Fixture	
		Diameter	External diameter	Length	Max. thickness	Hole diameter
		d [mm]	d _{nom} [mm]	L [mm]	t _{fix} [mm]	d _f [mm]
M6	R-RBL-M06/10W	6	12	55	10	6.5
	R-RBL-M06/25W	6	12	70	25	6.5
	R-RBL-M06/40W	6	12	85	40	6.5
M8	R-RBL-M08/10W	8	14	65	10	9
	R-RBL-M08/25W	8	14	80	25	9
	R-RBL-M08/40W	8	14	95	40	9
M10	R-RBL-M10/10W	10	16	75	10	11
	R-RBL-M10/25W	10	16	90	25	11
	R-RBL-M10/50W	10	16	115	50	11
	R-RBL-M10/75W	10	16	140	75	11
M12	R-RBL-M12/10W	12	20	90	10	13
	R-RBL-M12/25W	12	20	105	25	13
	R-RBL-M12/40W	12	20	120	40	13
	R-RBL-M12/60W	12	20	140	60	13
M16	R-RBL-M16/15W	16	25	135	15	17
	R-RBL-M16/30W	16	25	150	30	17
	R-RBL-M16/60W	16	25	180	60	17
M20	R-RBL-M20/60W	20	32	195	60	22
	R-RBL-M20/100W	20	32	235	110	22

R-RBP

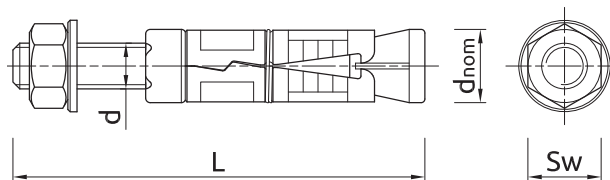

Size	Product Code	Anchor			Fixture	
		Bolt diameter	External diameter	Length	Max. thickness	Hole diameter
		d [mm]	d _{nom} [mm]	L [mm]	t _{fix} [mm]	d _f [mm]
M6	R-RBP-M06/10W	6	12	65	10	6.5
	R-RBP-M06/25W	6	12	80	25	6.5
	R-RBP-M06/60W	6	12	115	60	6.5
M8	R-RBP-M08/10W	8	14	75	10	9
	R-RBP-M08/25W	8	14	90	25	9
	R-RBP-M08/60W	8	14	125	60	9
M10	R-RBP-M10/15W	10	16	90	15	11
	R-RBP-M10/30W	10	16	105	30	11
	R-RBP-M10/60W	10	16	135	60	11

Product information (cont.)

Size	Product Code	Anchor			Fixture	
		Bolt diameter	External diameter	Length	Max. thickness	Hole diameter
		d [mm]	d _{nom} [mm]	L [mm]	t _{fix} [mm]	d _f [mm]
M12	R-RBP-M12/15W	12	20	110	15	13
	R-RBP-M12/30W	12	20	125	30	13
	R-RBP-M12/75W	12	20	170	75	13
M16	R-RBP-M16/15W	16	25	150	15	17
	R-RBP-M16/35W	16	25	170	35	17
	R-RBP-M16/75W	16	25	210	75	17
M20	R-RBP-M20/15W	20	32	170	15	22
	R-RBP-M20/30W	20	32	185	30	22
	R-RBP-M20/100W	20	32	255	100	22

Installation data

R-RBL

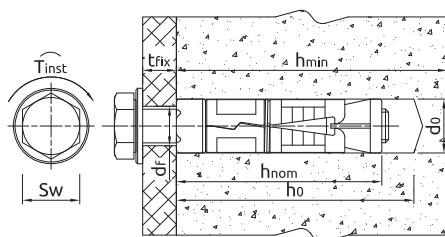

Installation in ceramic substrates

R-RBP

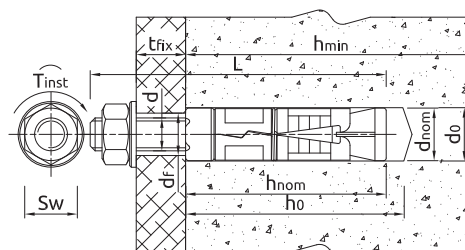

R-RBL

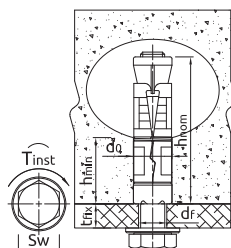

Installation in hollow core slab

R-RBP

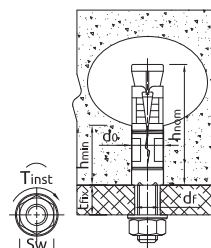

Size			M6	M8	M10	M12	M16	M20
Thread diameter	d	[mm]	6	8	10	12	16	20
Hole diameter in substrate	d _o	[mm]	12	14	16	20	25	32
Wrench size	Sw	[mm]	10	13	17	19	24	30
SOLID AND HOLLOW SUBSTRATES*								
Installation torque	T _{inst}	[Nm]	3	6.5	12	20	30	50
Min. hole depth in substrate	h _o	[mm]	50	55	65	85	125	140
Installation depth	h _{nom}	[mm]	45	50	60	80	120	135
Min. substrate thickness	h _{min}	[mm]	100	100	100	100	142	172
HOLLOW CORE SLABS								
Installation torque	T _{inst}	[Nm]	6.5	15	27	50	120	230
Min. hole depth in substrate	h _o	[mm]	-	-	-	-	-	-
Installation depth	h _{nom}	[mm]	45	50	60	80	120	135
Min. substrate thickness	h _{min}	[mm]	23	23	35	40	50	50

*hollow substrates
** rest of substrates

Mechanical properties

Size			M6	M8	M10	M12	M16	M20
Nominal ultimate tensile strength - tension	f_{uk}	[N/mm ²]	500	500	500	500	500	500
Nominal yield strength - tension	f_{yk}	[N/mm ²]	400	400	400	400	400	400
Cross sectional area - tension	A_s	[mm ²]	20.1	36.6	58.0	84.3	157.0	245.0
Elastic section modulus	W_{el}	[mm ³]	21.21	50.27	98.17	169.65	402.12	785.4
Characteristic bending resistance	$M^0_{Rk,s}$	[Nm]	12.72	30.16	58.9	101.79	241.27	471.24
Design bending resistance	M	[Nm]	10.18	24.13	47.12	81.43	193.02	376.99

Basic performance data

Performance data for single anchor without influence of edge distance and spacing

Size			M6	M8	M10	M12	M16	M20
CHARACTERISTIC LOAD								
TENSION AND SHEAR LOAD FR_{um}								
Hollow core slab min. C20/25								
Wall thickness	Material class							
23	C30/37	[kN]	4.36	5.44				
	C35/45	[kN]	4.82	6.02				
	C45/55	[kN]	5.35	6.67				
	C50/60	[kN]	5.81	7.25				
35	C30/37	[kN]	6.61	11.42	16.07			
	C35/45	[kN]	7.31	12.64	17.78			
	C45/55	[kN]	8.11	14.01	19.71			
	C50/60	[kN]	8.81	15.23	21.42			
40	C30/37	[kN]	7.30	16.94	19.19	25.46		
	C35/45	[kN]	8.08	18.75	21.23	28.18		--
	C45/55	[kN]	8.95	20.78	23.53	31.23		
	C50/60	[kN]	9.73	22.59	25.58	33.95		
50	C20/25	[kN]	8.45	8.93	8.93	8.93	8.93	8.93
Beam-and-block floor (eg.Terriva 4.0/2), min. 25mm wall thickness		[kN]	1.21	2.02				
Lightweight concrete LAC class 5		[kN]	5.98	5.99	5.99	5.99		
Solid clay brick class 20		[kN]	6.25	6.37	6.37	6.37		
Silicate hollow block class 15		[kN]	1.90					
DESIGN LOAD								
TENSION AND SHEAR LOAD FR_{um}								
Hollow core slab min. C20/25								
Wall thickness	Material class							
23	C30/37	[kN]	1.73	2.16				
	C35/45	[kN]	1.91	2.39				
	C45/55	[kN]	2.12	2.65				
	C50/60	[kN]	2.31	2.88				
35	C30/37	[kN]	2.62	4.53	6.38			
	C35/45	[kN]	2.90	5.02	7.06			
	C45/55	[kN]	3.22	5.56	7.82			
	C50/60	[kN]	3.50	6.04	8.50			
40	C30/37	[kN]	2.90	6.72	7.62	10.10		
	C35/45	[kN]	3.21	7.44	8.42	11.18		
	C45/55	[kN]	3.55	8.25	9.34	12.39		
	C50/60	[kN]	3.86	8.96	10.15	13.47		
50	C20/25	[kN]	3.35	3.54	3.54	3.54	3.54	3.54
Beam-and-block floor (eg.Terriva 4.0/2), min. 25mm wall thickness		[kN]	0.48	0.80				
Lightweight concrete LAC class 5		[kN]	1.95	1.96	1.96	1.96		
Solid clay brick class 20		[kN]	2.16	2.20	2.20	2.20		
Silicate hollow block class 15		[kN]	0.75					

Basic performance data (cont.)

Size			M6	M8	M10	M12	M16	M20
RECOMMENDED LOAD								
TENSION AND SHEAR LOAD $F_{R,u,m}$								
Hollow core slab min. C20/25								
Wall thickness	Material class							
23	C30/37	[kN]	1.24	1.54				
	C35/45	[kN]	1.37	1.71				
	C45/55	[kN]	1.52	1.89				
	C50/60	[kN]	1.65	2.05				
35	C30/37	[kN]	1.87	3.24	4.55			
	C35/45	[kN]	2.07	3.58	5.04			
	C45/55	[kN]	2.30	3.97	5.59			
	C50/60	[kN]	2.50	4.32	6.07			
40	C30/37	[kN]	2.07	4.80	5.44	7.22		
	C35/45	[kN]	2.29	5.31	6.02	7.99		
	C45/55	[kN]	2.54	5.89	6.67	8.85		
	C50/60	[kN]	2.76	6.40	7.25	9.62		
50	C20/25	[kN]	2.40	2.53	2.53	2.53	2.53	2.53
Beam-and-block floor (eg.Terriva 4.0/2), min. 25mm wall thickness		[kN]	0.34	0.57				
Lightweight concrete LAC class 5		[kN]	1.40	1.40	1.40	1.40		
Solid clay brick class 20		[kN]	1.54	1.57	1.57	1.57		
Silicate hollow block class 15		[kN]	0.54					

Product commercial data

Size	Product Code	Anchor		Quantity [pcs]			Weight [kg]			Bar Code
		Diameter [mm]	Length [mm]	Box	Outer	Pallet	Box	Outer	Pallet	
Rawlbolt R-RBL Loose Bolt										
M6	R-RBL-M06/10W	6	55	50	400	16000	1.56	12.4	527.6	5906675283210
	R-RBL-M06/25W	6	70	50	50	16000	1.65	13.2	556.4	5906675283234
	R-RBL-M06/40W	6	85	50	50	8000	1.81	1.81	319.6	5906675283258
M8	R-RBL-M08/10W	8	65	50	50	16000	2.7	21.6	895.6	5906675283272
	R-RBL-M08/25W	8	80	50	50	8000	3.0	3.0	502.0	5906675283296
	R-RBL-M08/40W	8	95	50	50	8000	3.2	3.2	541.2	5906675283319
M10	R-RBL-M10/10W	10	75	50	50	8000	4.6	4.6	765.2	5906675283333
	R-RBL-M10/25W	10	90	50	50	8000	5.0	5.0	832.4	5906675283357
	R-RBL-M10/50W	10	115	50	50	6000	5.6	5.6	705.6	5906675283371
	R-RBL-M10/75W	10	140	50	50	8000	6.4	6.4	1054.0	5906675283395
M12	R-RBL-M12/10W	12	90	25	25	4000	4.2	4.2	700.4	5906675283401
	R-RBL-M12/25W	12	105	25	25	4000	4.5	4.5	749.6	5906675283418
	R-RBL-M12/40W	12	120	25	25	3000	4.9	4.9	614.7	5906675283425
	R-RBL-M12/60W	12	140	25	25	4000	5.2	5.2	862.0	5906675283432
M16	R-RBL-M16/15W	16	135	10	10	1600	4.2	4.2	693.5	5906675283449
	R-RBL-M16/30W	16	150	10	10	1600	4.4	4.4	734.3	5906675283456
	R-RBL-M16/60W	16	180	10	10	1200	4.8	4.8	608.3	5906675283463
M20	R-RBL-M20/60W	20	195	10	10	1200	9.0	9.0	1113.5	5906675283487
	R-RBL-M20/100W	20	235	10	10	1200	9.8	9.8	1207.8	5906675283470

All products listed in this publication are branded and distributed with RAWLPLUG® or RAWL® trademarks.

Product commercial data (cont.)

Size	Product Code	Anchor		Quantity [pcs]			Weight [kg]			Bar Code
		Diameter [mm]	Length [mm]	Box	Outer	Pallet	Box	Outer	Pallet	
Rawlbolt R-RBP Bolt Projecting										
M6	R-RBP-M06/10W	6	65	50	400	16000	1.59	12.7	538.8	5906675283593
	R-RBP-M06/25W	6	80	50	400	16000	1.73	13.8	582.0	5906675283616
	R-RBP-M06/60W	6	115	50	50	8000	2.0	2.0	354.0	5906675283630
M8	R-RBP-M08/10W	8	75	50	400	16000	2.9	22.9	946.8	5906675283654
	R-RBP-M08/25W	8	90	50	50	8000	3.1	3.1	528.4	5906675283678
	R-RBP-M08/60W	8	125	50	50	8000	3.7	3.7	614.8	5906675283692
M10	R-RBP-M10/15W	10	90	50	50	8000	5.0	5.0	825.2	5906675283715
	R-RBP-M10/30W	10	105	50	50	6000	5.3	5.3	666.0	5906675283739
	R-RBP-M10/60W	10	135	50	50	8000	6.1	6.1	998.0	5906675283753
M12	R-RBP-M12/15W	12	110	25	25	4000	4.6	4.6	767.2	5906675283760
	R-RBP-M12/30W	12	125	25	25	4000	4.9	4.9	818.4	5906675283777
	R-RBP-M12/75W	12	170	25	25	3000	5.8	5.8	721.8	5906675283784
M16	R-RBP-M16/15W	16	150	10	10	1600	4.4	4.4	733.5	5906675283791
	R-RBP-M16/35W	16	170	10	10	1600	4.7	4.7	773.5	5906675283807
	R-RBP-M16/75W	16	210	10	10	1200	5.3	5.3	662.9	5906675283814
M20	R-RBP-M20/15W	20	170	10	10	1200	8.0	8.0	985.1	5906675283821
	R-RBP-M20/30W	20	185	10	10	1200	8.3	8.3	1030.4	5906675283838
	R-RBP-M20/100W	20	255	10	10	1200	9.9	9.9	1219.2	5906675284781

R-RBL-PF, R-RBP-PF RAWLBOLT Plastic Ferrule

World's most popular all-purpose expanding shield anchor



Approvals and Reports

- AT-15-7280/2014



Product overview

Features and benefits

- For use in concrete, hollowcore slabs, flooring blocks and ceramics
- Plastic ferrule simplifies installation in hollow substrates
- Wide range of diameters (M6 to M16)
- Three-piece expanding sleeve provides maximum expansion to ensure optimum loads and safety are achieved in various substrates

Applications

- Roller shutter doors
- Fire doors
- Steelwork
- Security grills
- Heavy machinery
- Installation of metal and plastic pipes in all pipework installations

Base materials

Approved for use in:

- Solid clay brick $\geq 20\text{MPa}$
- Hollow Lightweight Concrete Block LAC 5 $\geq 5\text{MPa}$
- Hollow Sand-lime Brick $\geq 15\text{MPa}$
- Concrete hollow floor block (eg. Teriva)
- Hollow-core Slab C20/25
- Hollow-core Slab C30/37-C50/60

Installation guide

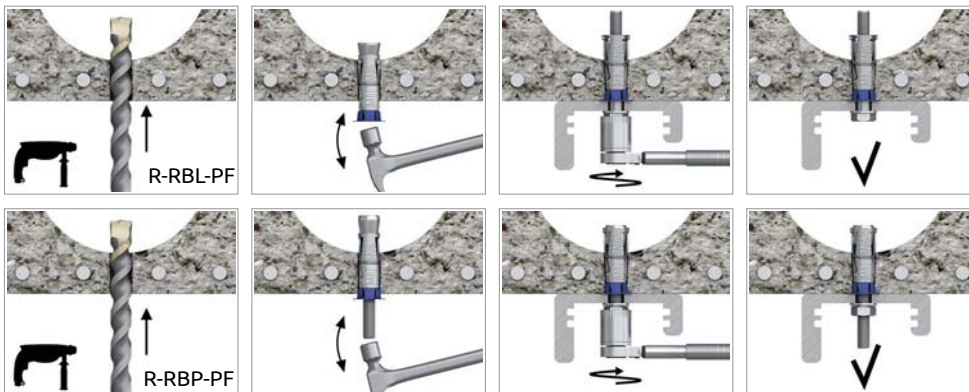

1. Drill a hole of required diameter and depth. Note: When fixing into brickwork, mortar joints should be avoided
2. Clear the hole of drilling dust and debris (using blow pump and brush or equivalent method)
3. Remove pre-assembled bolt and washer. Insert shield into hole and tap home with hammer until flush with surface
4. Insert bolt with washer through fixture into the shield
5. Tighten to the recommended torque

All products listed in this publication are branded and distributed with RAWLPLUG® or RAWL® trademarks.

Product information

R-RBL-PF

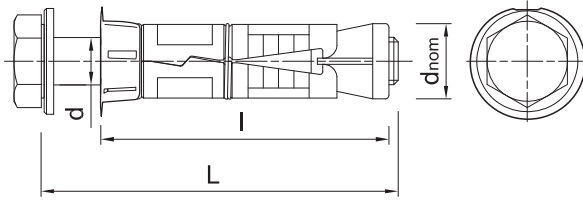

Size	Product Code	Anchor			Fixture	
		Bolt diameter	External diameter	Bolt length	Max. thickness	Hole diameter
		d	d _{nom}	L	t _{fix}	d _f
		[mm]	[mm]	[mm]	[mm]	[mm]
M6	R-RBL-PF-M06/10W	6	12	55	10	6.5
	R-RBL-PF-M06/25W	6	12	70	25	6.5
	R-RBL-PF-M06/40W	6	12	85	40	6.5
M8	R-RBL-PF-M08/10W	8	14	65	10	9
	R-RBL-PF-M08/25W	8	14	80	25	9
	R-RBL-PF-M08/40W	8	14	95	40	9
M10	R-RBL-PF-M10/10W	10	16	75	10	11
	R-RBL-PF-M10/25W	10	16	90	25	11
	R-RBL-PF-M10/50W	10	16	115	50	11
	R-RBL-PF-M10/75W	10	16	140	75	11
M12	R-RBL-PF-M12/10W	12	20	90	10	13
	R-RBL-PF-M12/25W	12	20	105	25	13
	R-RBL-PF-M12/40W	12	20	120	40	13
	R-RBL-PF-M12/60W	12	20	140	60	13
M16	R-RBL-PF-M16/15W	16	25	135	15	17
	R-RBL-PF-M16/30W	16	25	150	30	17
	R-RBL-PF-M16/60W	16	25	180	60	17

R-RBP-PF

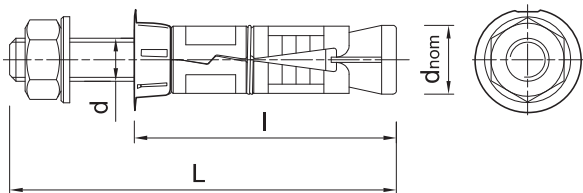

Size	Product Code	Anchor			Fixture	
		Bolt diameter	External diameter	Bolt length	Max. thickness	Hole diameter
		d	d _{nom}	L	t _{fix}	d _f
		[mm]	[mm]	[mm]	[mm]	[mm]
M6	R-RBP-PF-M06/10W	6	12	65	10	6.5
	R-RBP-PF-M06/25W	6	12	80	25	6.5
	R-RBP-PF-M06/60W	6	12	115	60	6.5
M8	R-RBP-PF-M08/10W	8	14	75	10	9
	R-RBP-PF-M08/25W	8	14	90	25	9
	R-RBP-PF-M08/60W	8	14	125	60	9
M10	R-RBP-PF-M10/15W	10	16	90	15	11
	R-RBP-PF-M10/30W	10	16	105	30	11
	R-RBP-PF-M10/60W	10	16	135	60	11
M12	R-RBP-PF-M12/15W	12	20	110	15	13
	R-RBP-PF-M12/30W	12	20	125	30	13
	R-RBP-PF-M12/75W	12	20	170	75	13
M16	R-RBP-PF-M16/15W	16	25	150	15	17
	R-RBP-PF-M16/35W	16	25	170	35	17
	R-RBP-PF-M16/75W	16	25	210	75	17

Installation data

R-RBL-PF

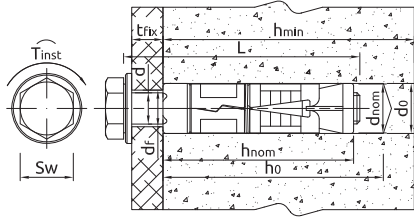

R-RBP-PF

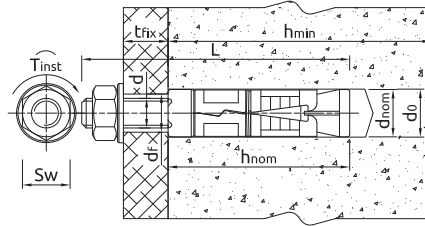

Installation in ceramic substrates

R-RBL-PF

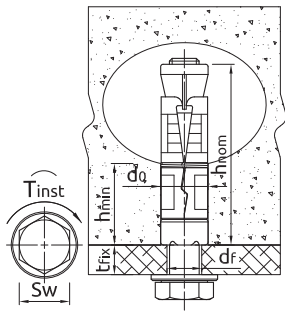

R-RBP-PF

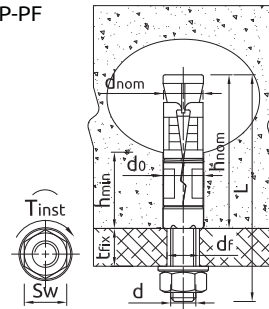

Installation in hollow core slab

Size			M6	M8	M10	M12	M16	M20
Thread diameter	d	[mm]	6	8	10	12	16	20
Hole diameter in substrate	d ₀	[mm]	12	14	16	20	25	32
Wrench size	Sw	[mm]	10	13	17	19	24	30
SOLID AND HOLLOW SUBSTRATES*								
Installation torque	T _{inst}	[Nm]	3	6.5	12	20	30	50
Min. hole depth in substrate	h ₀	[mm]	50	55	65	85	125	140
Installation depth	h _{nom}	[mm]	45	50	60	80	120	135
Min. substrate thickness	h _{min}	[mm]	100	100	100	100	142	172
HOLLOW CORE SLABS								
Installation torque	T _{inst}	[Nm]	6.5	15	27	50	120	230
Min. hole depth in substrate	h ₀	[mm]	-	-	-	-	-	-
Installation depth	h _{nom}	[mm]	45	50	60	80	120	135
Min. substrate thickness	h _{min}	[mm]	23	23	35	40	50	50

*hollow substrates
** rest of substrates

Mechanical properties

Size			M6	M8	M10	M12	M16
Nominal ultimate tensile strength - tension	f _{uk}	[N/mm ²]	500	500	500	500	500
Nominal yield strength - tension	f _{yk}	[N/mm ²]	400	400	400	400	400
Cross sectional area - tension	A _s	[mm ²]	20.1	36.6	58.0	84.3	157.0
Elastic section modulus	W _{el}	[mm ³]	21.21	50.27	98.17	169.65	402.12
Characteristic bending resistance	M ⁰ _{Rk,s}	[Nm]	12.72	30.16	58.9	101.79	241.27
Design bending resistance	M	[Nm]	10.18	24.13	47.12	81.43	193.02

Basic performance data

Performance data for single anchor without influence of edge distance and spacing

Size		M6	M8	M10	M12	M16	M20
CHARACTERISTIC LOAD							
TENSION AND SHEAR LOAD $F_{R,u,m}$							
Hollow core slab min. C20/25							
Wall thickness	Material class	[kN]					
23	C30/37	[kN]	4.36	5.44			
	C35/45	[kN]	4.82	6.02			
	C45/55	[kN]	5.35	6.67			
	C50/60	[kN]	5.81	7.25			
35	C30/37	[kN]	6.61	11.42	16.07		
	C35/45	[kN]	7.31	12.64	17.78		
	C45/55	[kN]	8.11	14.01	19.71		
	C50/60	[kN]	8.81	15.23	21.42		
40	C30/37	[kN]	7.30	16.94	19.19	25.46	
	C35/45	[kN]	8.08	18.75	21.23	28.18	--
	C45/55	[kN]	8.95	20.78	23.53	31.23	
	C50/60	[kN]	9.73	22.59	25.58	33.95	
50	C20/25	[kN]	8.45	8.93	8.93	8.93	8.93
Beam-and-block floor (eg.Terriva 4.0/2), min. 25mm wall thickness		[kN]	1.21	2.02			
Lightweight concrete LAC class 5		[kN]	5.98	5.99	5.99	5.99	
Solid clay brick class 20		[kN]	6.25	6.37	6.37	6.37	
Silicate hollow block class 15		[kN]	1.90				
DESIGN LOAD							
TENSION AND SHEAR LOAD $F_{R,u,m}$							
Hollow core slab min. C20/25							
Wall thickness	Material class	[kN]					
23	C30/37	[kN]	1.73	2.16			
	C35/45	[kN]	1.91	2.39			
	C45/55	[kN]	2.12	2.65			
	C50/60	[kN]	2.31	2.88			
35	C30/37	[kN]	2.62	4.53	6.38		
	C35/45	[kN]	2.90	5.02	7.06		
	C45/55	[kN]	3.22	5.56	7.82		
	C50/60	[kN]	3.50	6.04	8.50		
40	C30/37	[kN]	2.90	6.72	7.62	10.10	
	C35/45	[kN]	3.21	7.44	8.42	11.18	
	C45/55	[kN]	3.55	8.25	9.34	12.39	
	C50/60	[kN]	3.86	8.96	10.15	13.47	
50	C20/25	[kN]	13.47	3.54	3.54	3.54	3.54
Beam-and-block floor (eg.Terriva 4.0/2), min. 25mm wall thickness		[kN]	0.48	0.80			
Lightweight concrete LAC class 5		[kN]	1.95	1.96	1.96	1.96	
Solid clay brick class 20		[kN]	2.16	2.20	2.20	2.20	
Silicate hollow block class 15		[kN]	0.75				

Basic performance data (cont.)

Size		M6	M8	M10	M12	M16	M20	
RECOMMENDED LOAD								
TENSION AND SHEAR LOAD $F_{R,u,m}$								
Hollow core slab min. C20/25								
Wall thickness	Material class	[kN]						
23	C30/37	[kN]	1.24	1.54				
	C35/45	[kN]	1.37	1.71				
	C45/55	[kN]	1.52	1.89				
	C50/60	[kN]	1.65	2.05				
35	C30/37	[kN]	1.87	3.24	4.55			
	C35/45	[kN]	2.07	3.58	5.04			
	C45/55	[kN]	2.30	3.97	5.59			
	C50/60	[kN]	2.50	4.32	6.07			
40	C30/37	[kN]	2.07	4.80	5.44	7.22		
	C35/45	[kN]	2.29	5.31	6.02	7.99		
	C45/55	[kN]	2.54	5.89	6.67	8.85		
	C50/60	[kN]	2.76	6.40	7.25	9.62		
50	C20/25	[kN]	3.35	2.53	2.53	2.53	2.53	2.53
Beam-and-block floor (eg.Terriva 4.0/2), min. 25mm wall thickness		[kN]	0.34	0.57				
Lightweight concrete LAC class 5		[kN]	1.40	1.40	1.40	1.40		
Solid clay brick class 20		[kN]	1.54	1.57	1.57	1.57		
Silicate hollow block class 15		[kN]	0.54					

Product commercial data

799.5	Product Code	Anchor		Quantity [pcs]			Weight [kg]			Bar Code
		Diameter [mm]	Length [mm]	Box	Outer	Pallet	Box	Outer	Pallet	
Rawlbolt R-RBL-PF Loose Bolt										
M6	R-RBL-PF-M06/10W	6	55	50	400	16000	1.56	12.5	530.0	5906675380582
	R-RBL-PF-M06/25W	6	70	50	400	16000	1.61	12.9	546.0	5906675380599
	R-RBL-PF-M06/40W	6	85	50	50	8000	1.86	1.86	328.0	5906675380605
M8	R-RBL-PF-M08/10W	8	65	50	400	16000	2.7	21.7	898.0	5906675380612
	R-RBL-PF-M08/25W	8	80	50	50	8000	3.0	3.0	509.2	5906675375915
	R-RBL-PF-M08/40W	8	95	50	50	8000	3.3	3.3	560.0	5906675380629
M10	R-RBL-PF-M10/10W	10	75	50	50	8000	4.6	4.6	768.0	5906675375908
	R-RBL-PF-M10/25W	10	90	50	50	8000	5.0	5.0	832.0	5906675330068
	R-RBL-PF-M10/50W	10	115	50	50	6000	5.7	5.7	715.5	5906675380636
	R-RBL-PF-M10/75W	10	140	50	50	6000	6.4	6.4	799.5	5906675380643
M12	R-RBL-PF-M12/10W	12	90	25	25	4000	4.2	4.2	700.9	5906675380650
	R-RBL-PF-M12/25W	12	105	25	25	4000	4.6	4.6	758.5	5906675380667
	R-RBL-PF-M12/40W	12	120	25	25	3000	4.6	4.6	579.4	5906675380674
	R-RBL-PF-M12/60W	12	140	25	25	4000	5.2	5.2	862.5	5906675380681
M16	R-RBL-PF-M16/15W	16	135	10	10	1600	4.1	4.1	690.9	5906675380698
	R-RBL-PF-M16/30W	16	150	10	10	1600	4.4	4.4	726.1	5906675380704
	R-RBL-PF-M16/60W	16	180	10	10	1200	4.8	4.8	604.9	5906675380711

799.5	Product Code	Anchor		Quantity [pcs]			Weight [kg]			Bar Code
		Diameter [mm]	Length [mm]	Box	Outer	Pallet	Box	Outer	Pallet	
Rawlbolt R-RBP-PF Bolt Projecting										
M6	R-RBP-PF-M06/10W	6	65	50	400	16000	2.8	22.5	930.0	5906675380728
	R-RBP-PF-M06/25W	6	80	50	400	16000	1.66	13.3	562.0	5906675380735
	R-RBP-PF-M06/60W	6	115	50	50	8000	2.0	2.0	352.0	5906675380742
M8	R-RBP-PF-M08/10W	8	75	50	400	16000	2.9	23.0	950.8	5906675380759
	R-RBP-PF-M08/25W	8	90	50	50	8000	3.1	3.1	528.0	5906675380766
	R-RBP-PF-M08/60W	8	125	50	50	8000	3.7	3.7	616.8	5906675380773
M10	R-RBP-PF-M10/15W	10	90	50	50	8000	4.9	4.9	816.0	5906675380780
	R-RBP-PF-M10/30W	10	105	50	50	6000	5.3	5.3	667.5	5906675330075
	R-RBP-PF-M10/60W	10	135	50	50	8000	6.0	6.0	992.0	5906675380797
M12	R-RBP-PF-M12/15W	12	110	25	25	4000	4.1	4.1	678.5	5906675380803
	R-RBP-PF-M12/30W	12	125	25	25	4000	5.0	5.0	822.5	5906675380810
	R-RBP-PF-M12/75W	12	170	25	25	3000	5.8	5.8	722.2	5906675380827
M16	R-RBP-PF-M16/15W	16	150	10	10	1600	4.1	4.1	682.9	5906675380834
	R-RBP-PF-M16/35W	16	170	10	10	1600	4.7	4.7	774.1	5906675380841
	R-RBP-PF-M16/75W	16	210	10	10	1200	5.3	5.3	660.1	5906675380858

R-RBL-E, R-RBL-H Rawlbolt

World's most popular all-purpose expanding shield anchor



R-RBL-E



R-RBL-H



Approvals and Reports

- AT-15-7280/2014



Versions

- R-RBL-E Eye Bolt
- R-RBL-H Hook Bolt



Installation movie

Product overview

Features and benefits

- Hook and Eyebolt and hook designed & manufactured for maximum performance
- Three-piece expanding sleeve provides maximum expansion to ensure optimum loads and safety are achieved in various substrates
- Hook and Eye Rawlbolts are not suitable for fall arrest systems or shock loading

Applications

- Supporting guy ropes, stays and cables
- Supporting ladder restraints

Base materials

Suitable for use in:

- Cracked concrete C20/25-C50/60
- Non-cracked concrete C20/25-C50/60
- Unreinforced concrete
- Reinforced concrete
- Solid clay brick ≥ 20 MPa
- Hollow lightweight concrete Block LAC $5 \geq 5$ MPa
- Hollow sand-lime brick ≥ 15 MPa
- Concrete hollow floor block (eg. Teriva)
- Hollow-core Slab C20/25
- Hollow-core Slab C30/37-C50/60

Installation guide



All products listed in this publication are branded and distributed with RAWLPLUG® or RAWL® trademarks.

Installation guide

1. Drill a hole of required diameter and depth. Note: When fixing into brickwork, mortar joints should be avoided
2. Clear the hole of drilling dust and debris (using blow pump and brush or equivalent method)
3. Insert the anchor (tap home until flush with surface) and position eye/hook accordingly
4. Tighten to recommended torque, using the hex nut (not the eye/hook)

Product information

R-RBL-E

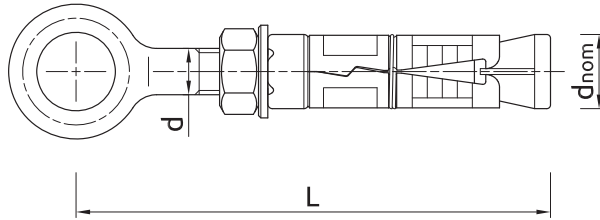

Size	Product Code	Anchor		
		Bolt diameter	External diameter	Length
		d [mm]	d _{nom} [mm]	L [mm]
M6	R-RBL-06EW	6	12	73
M8	R-RBL-08EW	8	14	87
M10	R-RBL-10EW	10	16	108
M12	R-RBL-12EW	12	20	130

R-RBL-H

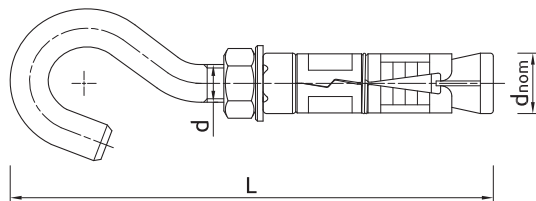

Size	Product Code	Anchor		
		Bolt diameter	External diameter	Length
		d [mm]	d _{nom} [mm]	L [mm]
M6	R-RBL-06HW	6	12	83
M8	R-RBL-08HW	8	14	98
M10	R-RBL-10HW	10	16	120
M12	R-RBL-12HW	12	20	145

Installation data

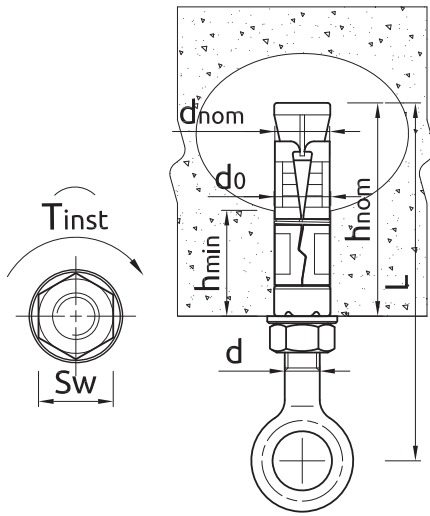

R-RBL-E

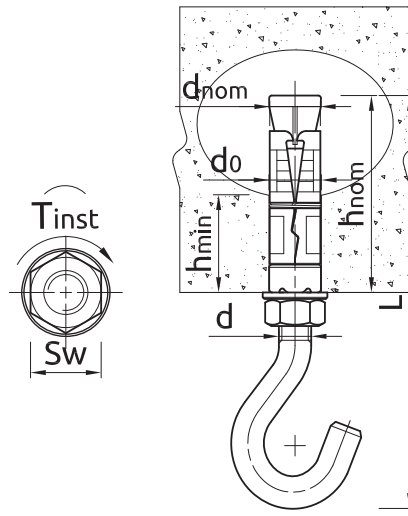

R-RBL-H

Size			M6	M8	M10	M12
Thread diameter	d	[mm]	6	8	10	12
Hole diameter in substrate	d ₀	[mm]	12	14	16	20
Wrench size	Sw	[mm]	10	13	17	19
SOLID SUBSTRATES CONCRETE						
Installation torque	T _{inst}	[Nm]	6.5	15	27	50
Min. hole depth in substrate	h ₀	[mm]	50	55	65	85
Installation depth	h _{nom}	[mm]	45	50	60	80
Min. substrate thickness	h _{min}	[mm]	100	100	100	100
Min. spacing	s _{min}	[mm]	35	40	50	60
Min. edge distance	c _{min}	[mm]	53	60	75	90
CERAMIC AND HOLLOW SUBSTRATES						
Installation torque	T _{inst}	[Nm]	3	6	12	20
Min. hole depth in substrate	h ₀	[mm]	50	55	65	85
Installation depth	h _{nom}	[mm]	45	50	60	80
Min. substrate thickness	h _{min}	[mm]	23	23	35	40
Min. spacing	s _{min}	[mm]	100	100	100	100
Min. edge distance	c _{min}	[mm]	100	100	100	100
Hollow core slab	T _{inst}	[Nm]	6.5	15	27	50

Basic performance data

Performance data for single anchor without influence of edge distance and spacing - ETAG 001

Size			M6	M8	M10	M12
CHARACTERISTIC LOAD						
TENSION AND SHEAR LOAD F_{Rk}						
Cracked concrete C20/25		[kN]	4.00	5.00	6.00	12.00
Non-cracked concrete C20/25		[kN]	6.00	7.50	12.00	16.00
Hollow core slab min. C20/25						
Wall thickness	Material class					
23	C30/37	[kN]	4.36	5.44	-	-
	C35/45	[kN]	4.82	6.02	-	-
	C45/55	[kN]	5.35	6.67	-	-
	C50/60	[kN]	5.81	7.25	-	-
35	C30/37	[kN]	6.61	11.42	16.07	-
	C35/45	[kN]	6.61	12.64	17.78	-
	C45/55	[kN]	6.61	13.13	19.00	-
	C50/60	[kN]	6.61	13.13	19.00	-
40	C30/37	[kN]	6.61	13.13	19.00	23.87
	C35/45	[kN]	6.61	13.13	19.00	23.87
	C45/55	[kN]	6.61	13.13	19.00	23.87
	C50/60	[kN]	6.61	13.13	19.00	23.87
50	C20/25	[kN]	6.61	8.93	8.93	8.93
Beam-and-block floor (eg.Terriva 4.0/2), min. 25mm wall thickness		[kN]	1.21	2.02	-	-
Lightweight concrete LAC class 5		[kN]	5.98	5.99	5.99	5.99
Solid clay brick class 20		[kN]	6.25	6.37	6.37	6.37
Silicate hollow block class 15		[kN]	1.90	-	-	-
DESIGN LOAD						
TENSION AND SHEAR LOAD F_{Rd}						
Cracked concrete C20/25		[kN]	2.22	2.78	3.33	6.67
Non-cracked concrete C20/25		[kN]	3.33	4.17	6.67	8.89
Hollow core slab min. C20/25						
Wall thickness	Material class					
23	C30/37	[kN]	1.73	2.16	-	-
	C35/45	[kN]	1.91	2.39	-	-
	C45/55	[kN]	2.12	2.65	-	-
	C50/60	[kN]	2.31	2.88	-	-
35	C30/37	[kN]	2.62	4.53	6.38	-
	C35/45	[kN]	2.90	5.02	7.06	-
	C45/55	[kN]	3.22	5.56	7.82	-
	C50/60	[kN]	3.50	6.04	8.50	-
40	C30/37	[kN]	2.90	6.72	7.62	10.10
	C35/45	[kN]	3.21	7.44	8.42	11.18
	C45/55	[kN]	3.55	8.25	9.34	12.39
	C50/60	[kN]	3.86	8.96	10.15	13.47
50	C20/25	[kN]	3.35	3.54	3.54	3.54
Beam-and-block floor (eg.Terriva 4.0/2), min. 25mm wall thickness		[kN]	0.48	0.80	-	-
Lightweight concrete LAC class 5		[kN]	1.95	1.96	1.96	1.96
Solid clay brick class 20		[kN]	2.16	2.20	2.20	2.20
Silicate hollow block class 15		[kN]	0.75	-	-	-

Basic performance data (cont.)

Size		M6	M8	M10	M12	
RECOMMENDED LOAD						
TENSION AND SHEAR LOAD F_{rec}						
Cracked concrete C20/25		[kN]	1.59	1.99	2.38	4.76
Non-cracked concrete C20/25		[kN]	2.38	2.98	4.76	6.35
Hollow core slab min. C20/25						
Wall thickness	Material class					
23	C30/37	[kN]	1.24	1.54	-	-
	C35/45	[kN]	1.37	1.71	-	-
	C45/55	[kN]	1.52	1.89	-	-
	C50/60	[kN]	1.65	2.05	-	-
35	C30/37	[kN]	1.87	3.24	4.55	-
	C35/45	[kN]	2.07	3.58	5.04	-
	C45/55	[kN]	2.30	3.97	5.59	-
	C50/60	[kN]	2.50	4.32	6.07	-
40	C30/37	[kN]	2.07	4.80	5.44	7.22
	C35/45	[kN]	2.29	5.31	6.02	7.99
	C45/55	[kN]	2.54	5.89	6.67	8.85
	C50/60	[kN]	2.76	6.40	7.25	9.62
50	C20/25	[kN]	2.40	2.53	2.53	2.53
Beam-and-block floor (eg.Terriva 4.0/2), min. 25mm wall thickness		[kN]	0.34	0.57	-	-
Lightweight concrete LAC class 5		[kN]	1.40	1.40	1.40	1.40
Solid clay brick class 20		[kN]	1.54	1.57	1.57	1.57
Silicate hollow block class 15		[kN]	0.54	-	-	-

Product commercial data

Size	Product Code	Anchor		Quantity [pcs]			Weight [kg]			Bar Code
		Diameter [mm]	Length [mm]	Box	Outer	Pallet	Box	Outer	Pallet	
Rawlbolt R-RBL-E Eye Bolt										
M6	R-RBL-06EW	6	73	25	400	16000	0.92	14.7	617.2	5906675283128
M8	R-RBL-08EW	8	87	25	200	8000	1.61	12.8	543.6	5906675283142
M10	R-RBL-10EW	10	108	25	25	4000	2.9	2.9	492.4	5906675283166
M12	R-RBL-12EW	12	130	25	25	3000	5.2	5.2	652.8	5906675283180
R-RBL-H Hook Bolt										
M6	R-RBL-06HW	6	83	25	400	16000	1.08	1.73	721.2	5906675283135
M8	R-RBL-08HW	8	98	25	25	4000	1.79	1.79	316.8	5906675283159
M10	R-RBL-10HW	10	120	25	25	4000	3.1	3.1	530.8	5906675283173
M12	R-RBL-12HW	12	145	25	25	4000	5.8	5.8	962.8	5906675283197

R-RB Rawlbolt Shield

World's most popular all-purpose expanding shield anchor - shield



Product overview

Features and benefits

- Product recommended for applications requiring fire resistance
- Three-pieces expanding sleeve of maximum expansion provides optimal load and safety of use in any substrate
- Designed & manufactured for maximum performance

Applications

- Roller shutter doors
- Fire doors
- Wall plates
- Security grills
- Signs
- Manufacturing and installation of fencing
- Heavy machinery
- Pipework/duct work support
- Supporting guy ropes, stays and cables
- Supporting ladder restraints

Base materials

Suitable for use in:

- Cracked concrete C20/25-C50/60
- Non-cracked concrete C20/25-C50/60
- Unreinforced concrete
- Reinforced concrete
- Solid clay brick $\geq 20\text{MPa}$
- Hollow Lightweight Concrete Block LAC 5 $\geq 5\text{MPa}$
- Hollow Sand-lime Brick $\geq 15\text{MPa}$
- Concrete hollow floor block (eg.Teriva)
- Hollow-core Slab C20/25
- Hollow-core Slab C30/37-C50/60
- Natural Stone

Installation guide



1. Drill a hole of required diameter and depth. Note: When fixing into brickwork, mortar joints should be avoided
2. Remove debris and thoroughly clean hole with brush and pump
3. Tap home with hammer until flush with surface

Product information

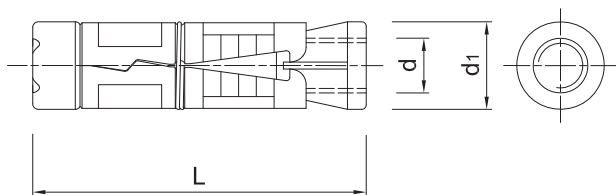

Size	Product Code	Anchor			Fixture
		Thread diameter	External diameter	Length	Hole diameter
		d	d_1	L	d_f
		[mm]	[mm]	[mm]	[mm]
M6	R-RB-M06W	6	12	45	6.5
M8	R-RB-M08W	8	14	50	9
M10	R-RB-M10W	10	16	60	11
M12	R-RB-M12W	12	20	75	13
M16	R-RB-M16W	16	25	115	17
M20	R-RB-M20W	20	32	130	22
M24	R-RB-M24W	24	38	150	26

Installation data

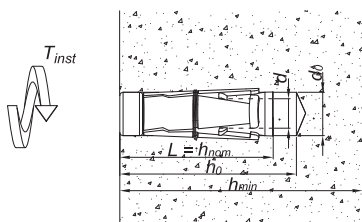

Size			M6	M8	M10	M12	M16	M20	M24
Thread diameter	d	[mm]	6	8	10	12	16	20	24
Hole diameter in substrate	d_0	[mm]	12	14	16	20	25	32	38
Installation torque	T_{inst}	[Nm]	6.5	15	27	50	120	230	400
Min. hole depth in substrate	h_0	[mm]	50	55	65	85	125	140	160
Installation depth	h_{nom}	[mm]	45	50	60	80	120	135	155
Min. substrate thickness	h_{min}	[mm]	100	100	100	100	142.5	172.5	240
Min. spacing	s_{min}	[mm]	35	40	50	60	95	115	210
Min. edge distance	c_{min}	[mm]	53	60	75	90	143	173	188

Product commercial data (cont.)

Size	Product Code	Anchor		Quantity [pcs]			Weight [kg]			Bar Code
		Diameter [mm]	Length [mm]	Box	Outer	Pallet	Box	Outer	Pallet	
R-RB Shield										
M6	R-RB-M06W	6	45	100	100	32000	1.79	14.3	602.8	5906675283517
M8	R-RB-M08W	8	50	100	100	16000	2.7	2.7	454.0	5906675283524
M10	R-RB-M10W	10	60	100	100	16000	4.0	4.0	671.6	5906675283531
M12	R-RB-M12W	12	75	50	50	8000	4.0	4.0	672.4	5906675283548
M16	R-RB-M16W	16	115	25	25	3000	4.3	4.3	550.8	5906675283555
M20	R-RB-M20W	20	130	15	15	1800	6.2	6.2	776.3	5906675283562
M24	R-RB-M24W	24	150	5	5	800	2.6	2.6	440.6	5906675283579

HEAVY-DUTY EXPANSION ANCHORS

SafetyPlus:

- R-SPLII-L
 - Loose Bolt
- R-SPLII-P
 - Bolt Projecting
- R-SPLII-C
 - Countersunk Bolt
- R-SPL
 - Loose Bolt
- R-SPL-BP
 - Bolt Projecting
- R-SPL-C
 - Countersunk Bolt

Case-hardened nut with optimum taper angle for maximum expansion

Integral controlled collapse and anti-rotation feature ensures fixture is firmly secured

Sleeve provides maximum shear load resistance



Unique zig-zag feature provides balanced expansion ensuring secure setting and maximum load carrying capacity

High strength steel washer

8.8 grade bolts

R-SPLII-L, R-SPLII-P, R-SPLII-C SafetyPlus

High performance mechanical anchor for cracked and non-cracked concrete

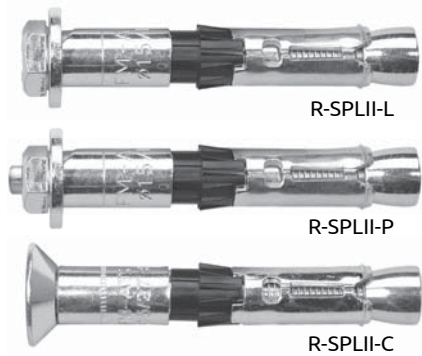

Approvals and Reports

- ETA-14/0345



Versions

- R-SPLII-L - Loose Bolt
- R-SPLII-P - Bolt Projecting
- R-SPLII-C - Countersunk

Product overview

Features and benefits

- Mechanical anchor for highest tension and shear loads
- Seismic category C2 for Structural applications. Seismic category C1 for non-structural use in areas with low seismic risk
- For usage with required fire resistance
- Option 1 ETA for Cracked and Non-Cracked Concrete
- Antirotation to prevent rotation during installation
- Anchor's construction allows easy through-installation (drilling and installation through fixed material)
- Three types of tips (nut, flat or tapered bolt) allow simple fitment for installed element
- 8.8 grade steel provides maximum performance and durability

Applications

- Structural steel
- Masonry support
- Cladding restraints
- Road Signs
- Heavy machinery
- Racking systems
- Industrial doors
- Safety barriers

Base materials

Approved for use in:

- Cracked concrete C20/25-C50/60
- Non-cracked concrete C20/25-C50/60
- Unreinforced concrete
- Reinforced concrete

Installation guide



All products listed in this publication are branded and distributed with RAWLPLUG® or RAWL® trademarks.

Installation guide (cont.)



1. Drill a hole of required diameter and depth
2. Clear the hole of drilling dust and debris (using blow pump and brush or equivalent method)
3. Insert anchor through fixture into hole and tap until required installation depth is achieved
4. Tighten to the recommended torque

Product information

R-SPLII-L

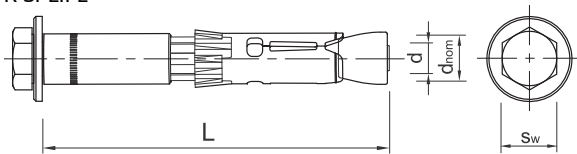

Size	Product Code	Anchor			Fixture	
		Bolt diameter	External diameter	Length	Max. thickness	Hole diameter
		d	d _{nom}	L	t _{fix}	d _f
		[mm]	[mm]	[mm]	[mm]	[mm]
R-SPLII SafetyPlus - Loose Bolt						
M6	R-SPL-II-06080/20L	6	10	80	20	12
	R-SPL-II-06110/50L	6	10	110	50	12
M8	R-SPL-II-08080/10L	8	12	80	10	14
	R-SPL-II-08090/20L	8	12	90	20	14
	R-SPL-II-08120/20L	8	12	120	50	14
M10	R-SPL-II-10090/10L	10	15	90	10	17
	R-SPL-II-10100/20L	10	15	100	20	17
	R-SPL-II-10130/50L	10	15	130	50	17
	R-SPL-II-10180100L	10	15	180	100	17
M12	R-SPL-II-12110/10L	12	18	110	10	20
	R-SPL-II-12125/25L	12	18	125	25	20
	R-SPL-II-12150/50L	12	18	150	50	20
	R-SPL-II-12200100L	12	18	200	100	20
M16	R-SPL-II-16125/10L	16	24	125	10	26
	R-SPL-II-16140/25L	16	24	140	25	26
	R-SPL-II-16165/50L	16	24	165	50	26
	R-SPL-II-16215100L	16	24	215	100	26

R-SPLII-P

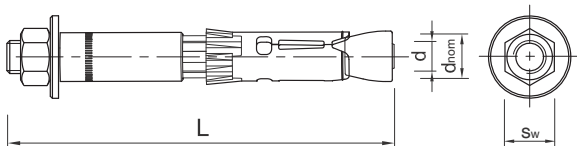

Size	Product Code	Anchor			Fixture	
		Bolt diameter	External diameter	Length	Max. thickness	Hole diameter
		d	d _{nom}	L	t _{fix}	d _f
		[mm]	[mm]	[mm]	[mm]	[mm]
R-SPLII-P SafetyPlus - Bolt Projecting						
M6	R-SPL-II-06110/50P	6	10	110	50	12
M8	R-SPL-II-08090/20P	8	12	90	20	14
M10	R-SPL-II-10100/20P	10	15	100	20	17
M12	R-SPL-II-12125/25P	12	18	125	25	20
	R-SPL-II-12150/50P	12	18	150	50	20
M16	R-SPL-II-16125/10P	16	24	125	10	26

Product information (cont.)

R-SPLII-C

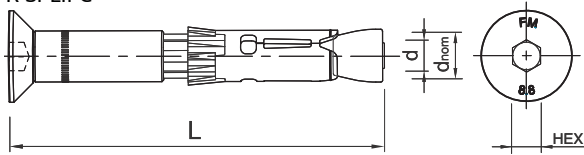

Size	Product Code	Anchor			Fixture	
		Bolt diameter	External diameter	Length	Max. thickness	Hole diameter
		d [mm]	d _{nom} [mm]	L [mm]	t _{fix} [mm]	d _f [mm]
R-SPLII-C SafetyPlus - Countersunk						
M6	R-SPL-II-06080/20C	6	10	80	20	12
M8	R-SPL-II-08080/16C	8	12	80	16	14
	R-SPL-II-08090/26C	8	12	90	26	14
M10	R-SPL-II-10090/17C	10	15	90	17	17
	R-SPL-II-10100/27C	10	15	100	27	17
M12	R-SPL-II-12125/33C	12	18	125	33	20

Installation data

R-SPLII-L

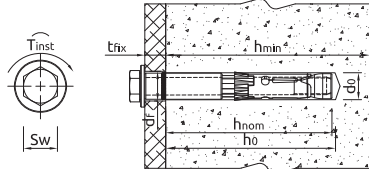

R-SPLII-P

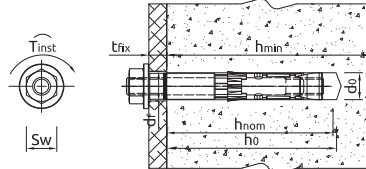

R-SPLII-C

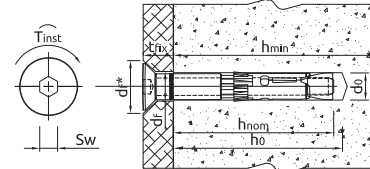

Size		M6	M8	M10	M12	M16*
Thread diameter	d [mm]	6	8	10	12	16
Hole diameter in substrate	d _o [mm]	10	12	15	18	24
Installation torque	T _{inst} [Nm]	10	20	45	80	150
Min. hole depth in substrate	h _o [mm]	75	85	95	115	130
Installation depth	h _{nom} [mm]	60	70	80	100	115
Min. substrate thickness	h _{min} [mm]	100	120	140	180	200
Min. spacing	s _{min} [mm]	50	60	70	80	100
Min. edge distance	c _{min} [mm]	50	60	70	80	100
Wrench size	S _w [mm]	10	13	17	19	24

*Size not offered in R-SPLII-C

Mechanical properties

Size		M6	M8	M10	M12	M16*
Nominal ultimate tensile strength - tension	f _{uk} [N/mm ²]	800	800	800	800	830
Nominal yield strength - tension	f _{yk} [N/mm ²]	640	640	640	640	660
Cross sectional area - tension	A _s [mm ²]	20.1	36.6	58.0	84.3	157.0
Elastic section modulus	W _{el} [mm ³]	21.2	50.3	98.2	169.7	402.1
Characteristic bending resistance	M ⁰ _{Rk,s} [Nm]	12	30	60	105	266
Design bending resistance	M [Nm]	9.6	24	48	84	214

*Size not offered in R-SPLII-C

Basic performance data

Performance data for single anchor without influence of edge distance and spacing

Size	M6	M8	M10	M12	M16*	M6	M8	M10	M12	M16*
Substrate	Non-cracked concrete					Cracked concrete				
Standard embedment depth h _{ef} [mm]	49.00	59.00	67.00	88.00	99.00	49.00	59.00	67.00	88.00	99.00
CHARACTERISTIC LOAD										
TENSION LOAD N _{Rk} [kN]	16.00	22.90	27.70	41.70	49.70	9.00	12.00	16.00	25.00	35.50
SHEAR LOAD V _{Rk} [kN]	14.00	22.90	42.00	50.00	97.00	12.30	16.30	39.50	50.00	70.90
DESIGN LOAD										
TENSION LOAD N _{Rd} [kN]	10.70	15.30	18.50	27.80	33.20	6.00	8.00	10.70	16.70	23.60
SHEAR LOAD V _{Rd} [kN]	11.20	15.30	33.60	40.00	66.30	8.23	10.88	26.30	39.60	47.30
RECOMMENDED LOAD										
TENSION LOAD N _{Rec} [kN]	7.62	10.90	13.20	19.90	23.70	4.29	5.71	7.62	11.90	16.90
SHEAR LOAD V _{Rec} [kN]	8.00	10.90	24.00	28.60	47.40	5.88	7.77	18.80	28.30	33.80

All products listed in this publication are branded and distributed with RAWLPLUG® or RAWL® trademarks.

Seismic performance data

Size		M6	M8	M10	M12	M16**	M6	M8	M10	M12	M16**
Seismic Performance Category		C1					C2				
Standard embedment depth h_{ef}	[mm]	49	59	67	88	99	49	59	67	88	99
CHARACTERISTIC LOAD											
TENSION STEEL FAILURE NRk.s.seis	[kN]	16.0	29.0	46.0	67.0	126.0	-	29.0	46.0	67.0	126.0
PULL-OUT FAILURE NRk.p.seis	[kN]	6.8	12.0	16.0	25.0	35.5*	-	3.9	7.8	15.3	28.8
SHEAR STEEL FAILURE VRk.s.seis	[kN]	9.8	13.0	20.0	20.0	48.5	-	10.2	17.0	17.0	43.9
DESIGN LOAD											
TENSION STEEL FAILURE NRd.s.seis	[kN]	10.7	19.3	30.7	44.7	84.0	-	19.3	30.7	44.7	84.0
PULL-OUT FAILURE NRd.p.seis	[kN]	4.5	8.0	10.7	16.7	23.7	-	2.6	5.2	10.2	19.2
SHEAR STEEL FAILURE VRd.s.seis	[kN]	7.84	6.4	16.0	16.0	38.8	-	8.16	13.6	13.6	35.1

*Pull-Out Failure not decisive
*Size not offered

Product commercial data

Size	Product Code	Anchor		Quantity [pcs]			Weight [kg]			Bar Code
		Diameter [mm]	Length [mm]	Box	Outer	Pallet	Box	Outer	Pallet	
R-SPLII SafetyPlus - Loose Bolt										
M6	R-SPL-II-06080/20L	6	80	50	400	9600	2.2	17.2	442.8	5010445007217
	R-SPL-II-06110/50L	6	110	50	300	7200	2.9	17.4	447.6	5010445007224
M8	R-SPL-II-08080/10L	8	80	25	200	4800	1.6	16.2	418.4	5010445007231
	R-SPL-II-08090/20L	8	90	25	200	4800	1.8	18.0	462.0	5010445007248
M10	R-SPL-II-08120/20L	8	120	25	150	3600	2.4	14.4	375.6	5010445007255
	R-SPL-II-10090/10L	10	90	20	160	3840	2.3	18.7	479.3	5010445007262
	R-SPL-II-10100/20L	10	100	20	160	3840	2.6	25.6	644.4	5010445007279
	R-SPL-II-10130/50L	10	130	20	120	2880	3.4	20.2	513.8	5010445007286
M12	R-SPL-II-10180100L	10	180	20	80	500	3.8	15.2	125.0	5906675375441
	R-SPL-II-12110/10L	12	110	20	80	1920	4.2	17.0	437.0	5010445007293
	R-SPL-II-12125/25L	12	125	20	20	3840	4.8	4.8	959.1	5010445007309
	R-SPL-II-12150/50L	12	150	20	20	3840	5.6	16.8	433.2	5010445007316
M16	R-SPL-II-12200100L	12	200	20	20	2100	4.8	4.8	959.1	5906675375458
	R-SPL-II-16125/10L	16	125	10	60	1440	4.4	26.2	659.3	5010445007323
	R-SPL-II-16140/25L	16	140	10	40	960	4.8	19.4	494.4	5010445007330
	R-SPL-II-16165/50L	16	165	10	10	890	5.7	5.7	535.5	5906675375465
	R-SPL-II-16215100L	16	215	10	10	700	7.1	7.1	5228.4	5906675375472
R-SPLII-P SafetyPlus - Bolt Projecting										
M6	R-SPL-II-06110/50P	6	110	50	300	7200	3.0	17.7	454.8	5010445007354
M8	R-SPL-II-08090/20P	8	90	25	200	4800	1.73	13.8	362.2	5010445007361
M10	R-SPL-II-10100/20P	10	100	20	160	3840	2.6	20.6	525.4	5010445007378
M12	R-SPL-II-12125/25P	12	125	20	20	3840	4.5	4.5	899.6	5010445007385
	R-SPL-II-12150/50P	12	150	20	20	2200	4.5	4.5	527.2	5906675375489
M16	R-SPL-II-16125/10P	16	125	10	60	1440	4.3	25.9	652.1	5010445007392
R-SPLII-C SafetyPlus - Countersunk										
M6	R-SPL-II-06080/20C	6	80	50	400	9600	2.1	16.6	429.4	5010445007408
M8	R-SPL-II-08080/16C	8	80	25	250	6000	1.88	18.8	480.0	5906675375496
	R-SPL-II-08090/26C	8	90	25	200	4800	1.79	14.4	374.3	5010445007415
M10	R-SPL-II-10090/17C	10	90	20	20	4060	2.5	2.5	541.6	5906675375502
	R-SPL-II-10100/27C	10	100	20	200	3840	2.3	23.2	586.8	5010445007422
M12	R-SPL-II-12125/33C	12	125	20	80	1920	4.5	18.1	463.9	5010445007439

R-SPL, R-SPL-BP, R-SPL-C SafetyPlus

High performance mechanical anchor

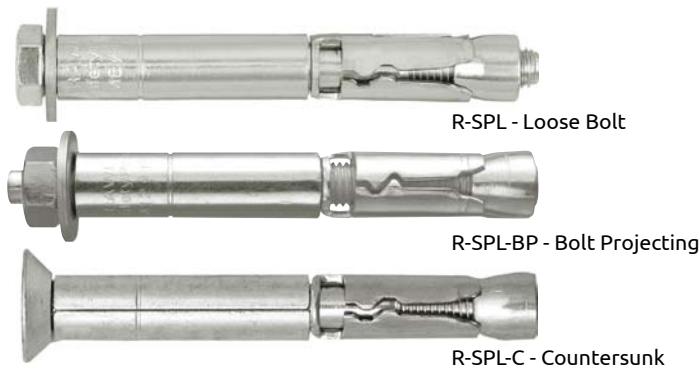

Approvals and Reports

- ETA-11/0126



Versions

- R-SPL - Loose Bolt
- R-SPL-BP - Bolt Projecting
- R-SPL-C - Countersunk

Product overview

Features and benefits

- Design of SafetyPlus allows easy through fixing
- Integral controlled collapse and anti-rotation feature ensures fixture is firmly secured
- Unique zig-zag feature provides balanced expansion
- Ensuring secure setting and maximised load-bearing capacity
- Case-hardened nut with optimum taper angle for enhanced expansion

Applications

- Structural steel
- Masonry support
- Cladding restraints
- Road Signs
- Heavy machinery
- Racking systems
- Industrial doors
- Safety barriers

Base materials

Approved for use in:

- Non-cracked concrete C20/25-C50/60
- Unreinforced concrete
- Reinforced concrete

Installation guide



All products listed in this publication are branded and distributed with RAWLPLUG® or RAWL® trademarks.

Installation guide



1. Drill a hole of required diameter and depth
2. Clear the hole of drilling dust and debris (using blow pump and brush or equivalent method)
3. Insert anchor through fixture into hole and tap until required installation depth is achieved
4. Tighten to the recommended torque

Product information

R-SPL

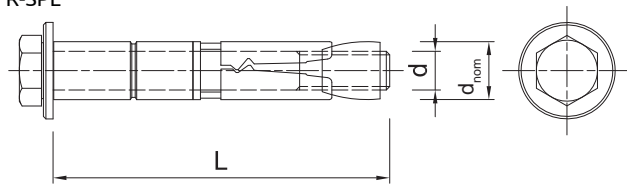

Size	Product Code	Anchor			Fixture	
		Thread size	External diameter	Length	Max. thickness	Hole diameter
		d [mm]	d _{nom} [mm]	L [mm]	t _{fix} [mm]	d _f [mm]
M8	R-SPL-08090/15	8	12	90	15	14
	R-SPL-08110/40	8	12	110	40	14
M10	R-SPL-10105/20	10	15	105	20	17
	R-SPL-10120/40	10	15	120	40	17
	R-SPL-10140/60	10	15	140	60	17
M12	R-SPL-12120/25	12	18	120	25	20
	R-SPL-12150/50	12	18	150	50	20
M16	R-SPL-16145/25	16	24	145	25	26
	R-SPL-16170/50	16	24	170	50	26
M20	R-SPL-20175/30	20	28	175	30	30

R-SPL-BP

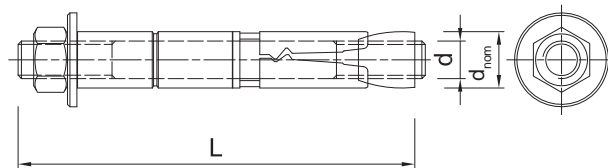

Size	Product Code	Anchor			Fixture	
		Thread size	External diameter	Length	Max. thickness	Hole diameter
		d [mm]	d _{nom} [mm]	L [mm]	t _{fix} [mm]	d _f [mm]
M10	R-SPL-BP-10110/20	10	15	110	20	17
M12	R-SPL-BP-12135/25	12	18	135	25	20
	R-SPL-BP-12160/50	12	18	160	50	20
M16	R-SPL-BP-16160/25	16	24	160	25	26
	R-SPL-BP-16185/50	16	24	185	50	26
M20	R-SPL-BP-20190/30	20	28	190	30	30

Product information (cont.)

R-SPL-C

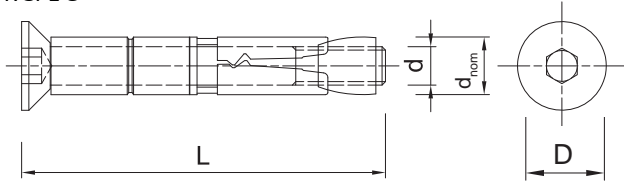

Size	Product Code	Anchor				Fixture	
		Thread size	External diameter	Head diameter	Length	Max. thickness	Hole diameter
		d [mm]	d _{nom} [mm]	D [mm]	L [mm]	t _{fix} [mm]	d _f [mm]
M8	R-SPL-C-08090/20	8	12	22	90	20	14
M10	R-SPL-C-10105/25	10	15	28	105	25	17
M12	R-SPL-C-12125/30	12	18	33	120	30	20
M16	R-SPL-C-16145/30	16	24	40	145	30	26

Installation data

R-SPL

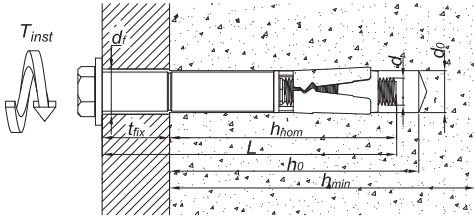

R-SPL-BP

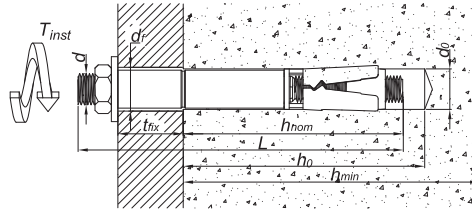

R-SPL-C

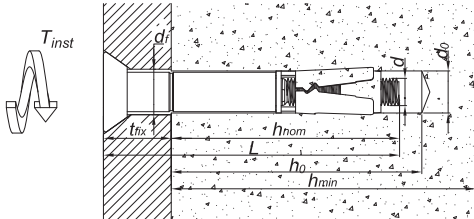

Size	M8	M10	M12	M16	M20*		
Thread diameter	d	[mm]	8	10	12	16	20
Hole diameter in substrate	d ₀	[mm]	12	15	18	24	28
Min. hole depth in substrate	h ₀	[mm]	80	90	100	125	155
Installation depth	h _{nom}	[mm]	70	80	90	110	130
Wrench size R-SPL	S _w	[mm]	13	17	19	24	30
Wrench size R-SPL	S _w	[mm]	6	8	10	12	-
Min. substrate thickness	h _{min}	[mm]	100	105	120	150	188
Min. spacing	s _{min}	[mm]	60	70	80	100	125
Min. edge distance	c _{min}	[mm]	90	105	120	150	186

*Size not offered in R-SPL-C

Mechanical properties

R-SPL, R-SPL-BP

Size	M8	M10	M12	M16	M20		
Nominal ultimate tensile strength - tension	f _{uk}	[N/mm ²]	800	800	800	800	830
Nominal yield strength - tension	f _{yk}	[N/mm ²]	640	640	640	640	640
Cross sectional area - tension	A _s	[mm ²]	36.6	58.0	84.3	157.0	245.0
Elastic section modulus	W _{el}	[mm ³]	50.3	98.2	169.7	402.1	785.4
Characteristic bending resistance	M ⁰ _{Rk,s}	[Nm]	45.04	87.97	152.01	365.97	728.54
Design bending resistance	M	[Nm]	36.03	70.38	121.61	292.78	592.83

All products listed in this publication are branded and distributed with RAWLPLUG® or RAWL® trademarks.

Mechanical properties (cont.)

R-SPL-C

Size			M8	M10	M12	M16
Nominal ultimate tensile strength - tension	F_{uk}	[N/mm ²]	800	800	800	800
Nominal yield strength - tension	f_{yk}	[N/mm ²]	640	640	640	640
Cross sectional area - tension	A_s	[mm ²]	36.6	58.0	84.3	157.0
Elastic section modulus	W_{el}	[mm ³]	50.3	98.2	169.7	402.1
Characteristic bending resistance	$M^0_{Rk,s}$	[Nm]	45.04	87.97	152.01	366.0
Design bending resistance	M	[Nm]	36.03	70.38	121.61	293.0

Basic performance data

Performance data for single anchor without influence of edge distance and spacing

Size		M8**	M10	M12	M16	M20*
Embedment depth h_{ef}	[mm]	60.0	70.0	80.0	100.0	125.0
CHARACTERISTIC LOAD						
TENSION LOAD N_{Rk}	[kN]	9.00**	12.00	16.00	35.00	40.00
SHEAR LOAD V_{Rk}	[kN]	18.00**	24.00	32.00	70.00	73.68
DESIGN LOAD						
TENSION LOAD N_{Rd}	[kN]	4.29**	5.71	7.62	16.67	19.05
SHEAR LOAD V_{Rd}	[kN]	8.57**	11.4	15.2	33.33	38.10
RECOMMENDED LOAD						
TENSION LOAD N_{rec}	[kN]	3.06**	4.08	5.44	11.90	13.61
SHEAR LOAD V_{rec}	[kN]	6.12**	8.16	10.89	23.81	27.21

*Size not offered in R-SPL-C

**Not for R-SPL-BL

Product commercial data

Size	Product Code	Anchor		Quantity [pcs]			Weight [kg]			Bar Code
		Diameter [mm]	Length [mm]	Box	Outer	Pallet	Box	Outer	Pallet	
R-SPL SafetyPlus - Loose Bolt										
M8	R-SPL-08090/15	8	90	50	50	8000	3.8	3.8	638.0	5010445500107
	R-SPL-08110/40	8	110	50	50	8000	4.6	4.6	770.8	5010445500152
M10	R-SPL-10105/20	10	105	50	50	8000	6.6	6.6	1089.2	5010445500206
	R-SPL-10120/40	10	120	50	50	6000	7.9	7.9	976.2	5010445500251
M12	R-SPL-10140/60	10	140	50	50	4000	9.0	9.0	752.0	5010445500305
	R-SPL-12120/25	12	120	25	25	4000	5.8	5.8	956.4	5010445500350
M16	R-SPL-12150/50	12	150	25	25	3000	7.0	7.0	870.6	5010445500404
	R-SPL-16145/25	16	145	10	10	1600	4.8	4.8	801.4	5010445500503
M20	R-SPL-16170/50	16	170	10	10	1200	5.6	5.6	700.3	5010445500558
M20	R-SPL-20175/30	20	175	10	10	1200	8.4	8.4	1033.4	5010445500657
R-SPL-BP SafetyPlus - Bolt Projecting										
M10	R-SPL-BP-10110/20	10	110	50	50	8000	6.4	6.4	1046.8	5010445501203
M12	R-SPL-BP-12135/25	12	135	25	25	4000	5.7	5.7	935.6	5010445501357
	R-SPL-BP-12160/50	12	160	25	25	4000	6.6	6.6	1080.4	5010445501401
M16	R-SPL-BP-16160/25	16	160	10	10	1600	4.7	4.7	780.9	5010445501500
	R-SPL-BP-16185/50	16	185	10	10	1200	5.5	5.5	687.8	5010445501555
M20	R-SPL-BP-20190/30	20	190	10	10	1200	8.0	8.0	988.6	5010445501654
R-SPL-C SafetyPlus - Countersunk										
M8	R-SPL-C-08090/20	8	90	50	50	8000	3.6	3.6	605.2	5010445502101
M10	R-SPL-C-10105/25	10	105	50	50	8000	6.6	6.6	1085.2	5010445502200
M12	R-SPL-C-12125/30	12	120	25	25	4000	5.8	5.8	949.2	5010445502354
M16	R-SPL-C-16145/30	16	145	10	10	1600	4.6	4.6	763.4	5010445502507

DROP-IN ANCHORS

- R-DCA-A4
 - Stainless Steel Drop-in Anchors
- R-DCA
 - Drop-in Anchors
- R-DCL
 - Lipped Drop-in Anchors



Easy to install by hammer action



Internally threaded to take stud or bolt



Slotted sleeve and internal wedge component facilitate easy setting

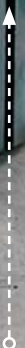

R-DCA-A4 Stainless Steel Drop-in Anchors

Internally threaded stainless steel drop-in anchors for simple hammer-set installation

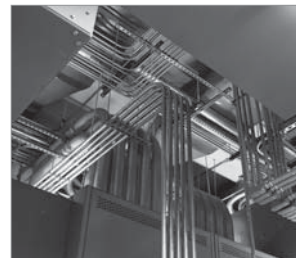

Approvals and Reports

- ETA-13/0584
- KOT-2017-0165



Product overview

Features and benefits

- High performance in cracked and non-cracked concrete confirmed by ETA
- Product recommended for applications requiring fire resistance
- Stainless steel material for high resistance to corrosion
- Easy to install by hammer action
- Slotted sleeve and internal wedge component together facilitate easy setting and expansion

Applications

- Pipelines systems
- Ventilation systems
- Sprinkler systems
- Cable conduits and wires
- Gratings

Base materials

Approved for use in:

- Cracked concrete C20/25-C50/60
- Non-cracked concrete C20/25-C50/60
- Unreinforced concrete
- Reinforced concrete

Installation guide



1. Drill a hole of required diameter and depth
2. Clear the hole of drilling dust and debris (using blow pump and brush or equivalent method)
3. Insert wedge anchor, slotted end first
4. Use the setting tool to drive the internal wedge into the anchor
5. Insert bolt or stud through fixture and tighten to the recommended torque

Product information

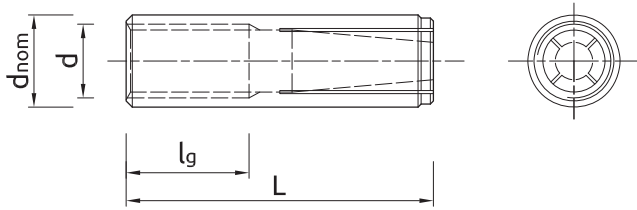

Size	Product Code	Anchor				Fixture
		Diameter	External diameter	Length	Internal thread length	Hole diameter
		d [mm]	d _{nom} [mm]	L [mm]	l _g [mm]	d _f [mm]
M6	R-DCA-06-25-A4	6	8	25	11	7
M8	R-DCA-08-30-A4	8	10	30	14	9
M10	R-DCA-10-40-A4	10	12	40	19	12
M12	R-DCA-12-50-A4	12	15	50	25	14
M16	R-DCA-16-65-A4	16	20	65	28	18

Installation data

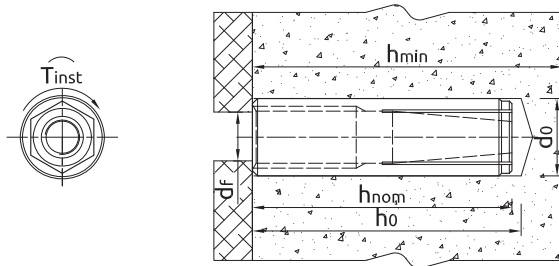

Size	M6	M8	M10	M12	M16		
Thread diameter	d	[mm]	6	8	10	12	16
Hole diameter in substrate	d ₀	[mm]	8	10	12	15	20
Installation torque	T _{inst}	[Nm]	4.5	11	22	38	98
Min. hole depth in substrate	h ₀	[mm]	30	32	42	53	70
Installation depth	h _{nom}	[mm]	25	30	40	50	65
Min. substrate thickness	h _{min}	[mm]		80		100	130
Min. spacing	s _{min}	[mm]		200			260
Min. edge distance	c _{min}	[mm]		150			195

Mechanical properties

Size	M6	M8	M10	M12	M16		
Nominal ultimate tensile strength - tension	f _{uk}	[N/mm ²]	500	500	500	500	500
Nominal yield strength - tension	f _{yk}	[N/mm ²]	210	210	210	210	210
Cross sectional area - tension	A _s	[mm ²]	20.1	36.6	58.0	84.3	157.0
Elastic section modulus	W _{el}	[mm ³]	21.21	50.27	98.17	169.65	402.12
Characteristic bending resistance	M ⁰ _{Rk,s}	[Nm]	17.81	42.22	82.47	142.5	337.78
Design bending resistance	M	[Nm]	11.88	28.15	54.98	95.0	225.19

Basic performance data

Performance data for single anchor without influence of edge distance and spacing

Size		M6	M8	M10	M12	M16
Embedment depth h_{ef}	[mm]	25	30	40	50	65
CHARACTERISTIC LOAD						
TENSION LOAD N_{Rk}	[kN]	1.00	2.01	3.20	4.59	8.27
SHEAR LOAD V_{Rk}	[kN]	1.00	2.01	3.20	4.59	8.27
DESIGN LOAD						
TENSION LOAD N_{Rd}	[kN]	0.48	0.96	1.52	2.19	3.94
SHEAR LOAD V_{Rd}	[kN]	0.48	0.96	1.52	2.19	3.94
RECOMMENDED LOAD						
TENSION LOAD N_{rec}	[kN]	0.34	0.68	1.09	1.56	2.81
SHEAR LOAD V_{rec}	[kN]	0.34	0.68	1.09	1.56	2.81

Product commercial data

Size	Product Code	Anchor		Quantity [pcs]			Weight [kg]			Bar Code
		Diameter [mm]	Length [mm]	Box	Outer	Pallet	Box	Outer	Pallet	
M6	R-DCA-06-25-A4	6	25	100	1000	100000	0.73	7.3	760.0	5010445776083
M8	R-DCA-08-30-A4	8	30	100	1000	64000	1.27	12.7	842.8	5010445776205
M10	R-DCA-10-40-A4	10	40	50	500	32000	1.18	11.8	785.2	5010445776328
M12	R-DCA-12-50-A4	12	50	50	400	16000	2.4	19.2	798.0	5010445776410
M16	R-DCA-16-65-A4	16	65	25	100	6000	2.8	11.3	706.8	5010445776502

R-DCA, R-DCL Drop-in Anchors

Internally-threaded wedge anchor for simple hammer-set installation

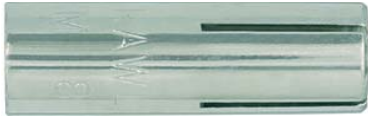

R-DCA - Drop-in Anchors



R-DCL - Lipped Drop-in Anchors

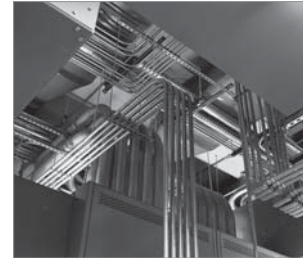

Approvals and Reports

- ETA-13/0584
- KOT-2017-0165 (R-DCA)



Versions

- R-DCA - Drop-in Anchors
- R-DCL - Lipped Drop-in Anchors



Installation movie

Product overview

Features and benefits

- High performance in cracked and non-cracked concrete confirmed by ETA and ITB technical approval
- Product recommended for applications requiring fire resistance
- Internally-threaded to be used with threaded stud or bolt
- Easy to install by hammer action
- Slotted sleeve and internal wedge component together facilitate easy setting and expansion

Applications

- Pipelines systems
- Ventilation systems
- Sprinkler systems
- Cable conduits and wires
- Gratings

Base materials

Approved for use in:

- Cracked concrete C20/25-C50/60
- Non-cracked concrete C20/25-C50/60
- Unreinforced concrete
- Reinforced concrete
- Hollow core slabs (only R-DCL)

Installation guide



1. Drill a hole of required diameter and depth
2. Clear the hole of drilling dust and debris (using blow pump and brush or equivalent method)
3. Insert wedge anchor, slotted end first
4. Use the setting tool to drive the internal wedge into the anchor
5. Insert bolt or stud through fixture and tighten to the recommended torque

All products listed in this publication are branded and distributed with RAWLPLUG® or RAWL® trademarks.

Product information

R-DCA

R-DCL

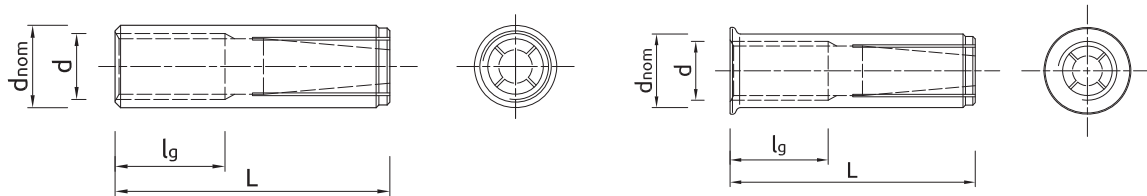

Size	Product Code	Anchor				Fixture
		Diameter	External diameter	Length	Internal thread length	Hole diameter
		d [mm]	d _{nom} [mm]	L [mm]	l _g [mm]	d _f [mm]
M6	R-DCA-06-25	6	8	25	11	7
M8	R-DCA-08-30	8	10	30	14	9
	R-DCA-08-30-100B	8	10	30	14	9
M10	R-DCA-10-40	10	12	40	19	12
	R-DCA-10-40-50B	10	12	40	19	12
M12	R-DCA-12-50	12	15	50	25	14
	R-DCA-12-50-30B	12	15	50	25	14
M16	R-DCA-16-65	16	20	65	28	18
	R-DCA-16-65-15B	16	20	65	28	18
M20	R-DCA-20-80	20	25	80	38	22

Size	Product Code	Anchor				Fixture
		Diameter	External diameter	Length	Internal thread length	Hole diameter
		d [mm]	d _{nom} [mm]	L [mm]	l _g [mm]	d _f [mm]
M6	R-DCL-06	6	8	25	11	7
M8	R-DCL-08-25	8	10	25	14	9
	R-DCL-08	8	10	30	14	9
M10	R-DCL-10-25	10	12	25	14	12
	R-DCL-10	10	12	40	19	12
M12	R-DCL-12-25	12	15	25	14	14
	R-DCL-12	12	15	50	25	14
M16	R-DCL-16	16	20	65	28	18

Installation data

R-DCA

R-DCL

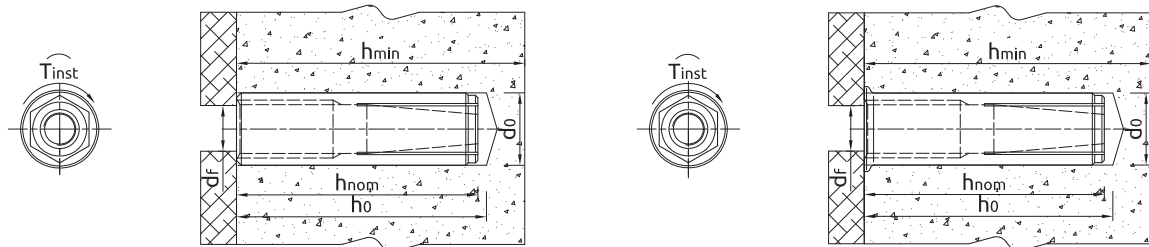

Size			M6	M8	M10	M12	M16	M20*
Thread diameter	d	[mm]	6	8	10	12	16	20
Hole diameter in substrate	d ₀	[mm]	8	10	12	15	20	25
Installation torque	T _{inst}	[Nm]	4.5	11	22	38	98	130
Min. hole depth in substrate	h ₀	[mm]	30	32	42	53	70	85
Installation depth	h _{nom}	[mm]	25	30	40	50	65	80
Min. substrate thickness	h _{min}	[mm]	80	80	80	100	130	160
Min. spacing	s _{min}	[mm]	105	105	220	220	220	225
Min. edge distance	c _{min}	[mm]	105	105	220	220	220	225

*not R-DCL

Mechanical properties

Size			M6	M8	M10	M12	M16	M20*
Nominal ultimate tensile strength - tension	f_{uk}	[N/mm ²]	450	450	450	450	450	450
Nominal yield strength - tension	f_{yk}	[N/mm ²]	360	360	360	360	360	360
Cross sectional area - tension	A_s	[mm ²]	20.1	36.6	58.0	84.3	157.0	245.0
Elastic section modulus	W_{el}	[mm ³]	21.21	50.3	98.2	169.7	402.1	785.4
Characteristic bending resistance	$M_{Rk,s}^0$	[Nm]	12.72	30.2	61.0	101.8	241.3	471.2
Design bending resistance	M	[Nm]	10.18	24.1	49.0	81.4	193.0	377.0

*not R-DCL

Basic performance data

Performance data for single anchor without influence of edge distance and spacing

Size		M6	M8	M10	M12	M16	M20*
Embedment depth h_{ef}	[mm]	25.0	30.0	40.0	50.0	65.0	80.0
CHARACTERISTIC LOAD							
TENSION LOAD N_{Rk}	[kN]	1.52	3.00	4.57	6.40	13.30	17.40
SHEAR LOAD V_{Rk}	[kN]	1.52	3.00	4.57	6.40	13.30	17.40
DESIGN LOAD							
TENSION LOAD N_{Rd}	[kN]	0.72	1.43	2.18	3.06	6.30	8.30
SHEAR LOAD V_{Rd}	[kN]	0.72	1.43	2.18	3.06	6.30	8.30
RECOMMENDED LOAD							
TENSION LOAD N_{rec}	[kN]	0.51	1.02	1.55	2.19	4.50	5.90
SHEAR LOAD V_{rec}	[kN]	0.51	1.02	1.55	2.19	4.50	5.90

*not R-DCL

Product commercial data

Size	Product Code	Anchor		Quantity [pcs]			Weight [kg]			Bar Code
		Thread size [mm]	Length [mm]	Box	Outer	Pallet	Box	Outer	Pallet	
R-DCA Wedge Anchor										
M6	R-DCA-06-25	6	25	100	1000	36000	0.67	6.7	271.2	5010445771088
M8	R-DCA-08-30	8	30	100	1000	60000	1.19	11.9	744.0	5010445771200
	R-DCA-08-30-100B	8	30	100	1700	54400	1.20	20.4	682.8	5906675439112
M10	R-DCA-10-40	10	40	50	500	37500	1.15	11.5	892.5	5906675151687
	R-DCA-10-40-50B	10	40	50	900	28800	1.15	20.7	692.4	5906675439136
M12	R-DCA-12-50	12	50	50	400	18000	2.3	18.3	854.4	5906675152004
	R-DCA-12-50-30B	12	50	30	360	11520	1.50	18.0	606.0	5906675438108
M16	R-DCA-16-65	16	65	25	100	6000	2.7	10.8	680.4	5010445771507
	R-DCA-16-65-15B	16	65	15	180	5760	1.53	18.4	617.5	5906675438115
M20	R-DCA-20-80 ¹⁾	20	80	15	90	3240	3.0	18.1	680.9	5010445002298
R-DCL Lipped Wedge Anchor										
M6	R-DCL-06	6	25	100	1000	56000	0.71	7.1	427.6	5010445779084
M8	R-DCL-08-25	8	25	100	1200	57600	1.06	12.8	640.5	5906675397320
	R-DCL-08	8	30	100	1200	57600	1.24	14.9	744.2	5010445779206
M10	R-DCL-10-25	10	25	50	600	36000	0.72	8.6	548.4	5906675397337
	R-DCL-10	10	40	50	600	36000	1.20	14.3	890.4	5010445779329
M12	R-DCL-12-25	12	25	50	200	6000	0.90	3.6	138.0	5906675418285
	R-DCL-12	12	50	50	200	6000	2.40	9.5	315.0	5010445779411
M16	R-DCL-16	16	65	25	150	6000	2.90	17.2	718.8	5010445779503

All products listed in this publication are branded and distributed with RAWLPLUG® or RAWL® trademarks.

R-DCA-ST-II/R-DCA-ST Drop-in Anchors Setting Tools

Manual setting tool for drop in anchor installation



R-DCA-ST-II

R-DCA-ST

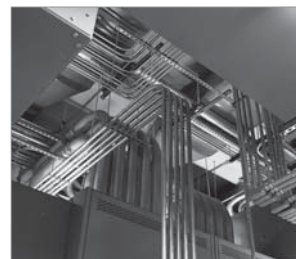

Approvals and Reports

- ETA-13/0584



Product overview

Features and benefits

- Manual installation of wedge anchors with rubber grip and hand protection

Applications

- Installation of drop in anchor

Installation guide

R-DCA-ST-II



R-DCA-ST



1. Use the manual setting tool with hammer to drive the internal wedge into the anchor

Product information

R-DCA-ST-II

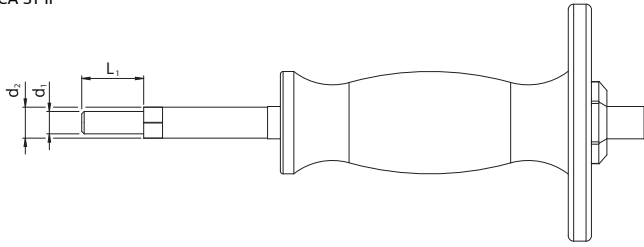

R-DCA-ST

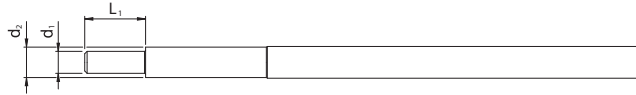

Size	Product Code	Diameter		
		Thread size	External diameter	Length
		d ₁	d ₂	L ₁
		[mm]	[mm]	[mm]
M6	R-DCA-ST-II-06 / R-DCA-ST-06	5	7.5	14.8
M8	R-DCA-ST-II-08-25	6.6	9.5	17
	R-DCA-ST-II-08 / R-DCA-ST-08	6.6	9.5	18
M10	R-DCA-ST-II-10-25	8.3	11.5	17
	R-DCA-ST-II-10 / R-DCA-ST-10	8.3	11.5	23
M12	R-DCA-ST-II-12-25	10.2	14.5	17
	R-DCA-ST-II-12 / R-DCA-ST-12	10.2	14.5	28
M16	R-DCA-ST-II-16 / R-DCA-ST-16	13.5	19.5	33
M20	R-DCA-ST-20	16.8	24.5	47

Product commercial data

Size	Product Code	Anchor		Quantity [pcs]			Weight [kg]			Bar Code
		Diameter [mm]	Length [mm]	Box	Outer	Pallet	Box	Outer	Pallet	
M6	R-DCA-ST-II-06	5	14.8	10	10	560	0.24	2.4	162.7	5906675423449
M8	R-DCA-ST-II-08-25	6.6	17	10	10	560	2.8	2.8	185.7	5906675430775
	R-DCA-ST-II-08	6.6	18	10	10	560	0.28	2.8	185.7	5906675423456
M10	R-DCA-ST-II-10-25	8.3	17	10	10	560	3.3	3.3	213.1	5906675430782
	R-DCA-ST-II-10	8.3	23	10	10	560	0.33	3.3	213.1	5906675423463
M12	R-DCA-ST-II-12-25	10.2	17	10	10	560	4.1	4.1	261.3	5906675432090
	R-DCA-ST-II-12	10.2	28	10	10	560	0.41	4.1	261.3	5906675423470
M16	R-DCA-ST-II-16	13.5	33	10	10	240	0.62	6.2	177.6	5906675423487
M6	R-DCA-ST-06	5	14.8	1	100	6000	0.08	8.0	510.0	5906675204888
M8	R-DCA-ST-08	6.6	18	1	100	6000	0.07	6.9	441.0	5906675204895
M10	R-DCA-ST-10	8.3	23	1	100	4500	0.13	13.0	615.0	5906675204901
M12	R-DCA-ST-12	10.2	28	1	50	3000	0.26	12.9	803.4	5906675204918
M16	R-DCA-ST-16	13.5	33	1	30	1350	0.54	16.3	761.3	5906675204925
M20	R-DCA-ST-20	16.8	47	1	20	900	0.39	7.8	381.0	5906675204932

Concrete screw re-usability testing gauge

Concrete screw re-usability testing gauge



Product overview

Features and benefits

- Testing Gauge allows to determine whether the product R-LX is suitable for re-use.

Applications

- Concrete screw re-usability testing gauge

Installation guide

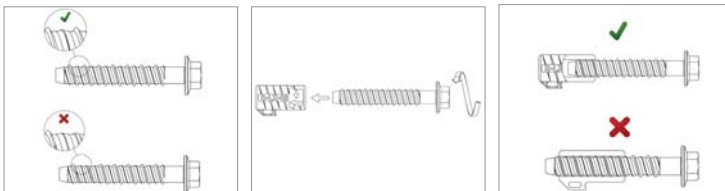

1. Visual assessment. The anchor thread shall not be damaged
2. Drive the screw counterclockwise into the no-go gauge with at least one revolution during the test. You can re-use the anchor if its tip is not visible on the other end of the no-go gauge
3. Screws which failed the test 1 or the test 2 are not recommended to use

Product information

Product Code	Description
R-S1-LX-TEST-08/2	Wear Gauge for R-LX-08
R-S1-LX-TEST-10/2	Wear Gauge for R-LX-10
R-S1-LX-TEST-14/2	Wear Gauge for R-LX-14

Product commercial data

Product Code	Description	Quantity [pcs]			Weight [kg]			Bar Code
		Box	Outer	Pallet	Box	Outer	Pallet	
R-S1-LX-TEST-08/2	Wear Gauge for R-LX-08	1	1	-	0.01	0.01	-	5906675437408
R-S1-LX-TEST-10/2	Wear Gauge for R-LX-10	1	1	-	0.02	0.02	-	5906675437545
R-S1-LX-TEST-14/2	Wear Gauge for R-LX-14	1	1	-	0.03	0.03	-	5906675439396

ACCESSORIES

- Tension Tester



Rawlplug Tension Tester Kit

Model 2000 tester kit for measurement of tensile loads on anchors



Product overview

Features and benefits

- Pull-out tester enables engineers to confirm the holding power of anchors in most construction materials

Applications

- Pull-out tester for testing fixings, fasteners and anchors

Instructions for use

1. Fit the appropriate button to the fastener to be tested
2. Slide the slot in the bolt tester adaptor over the button adaptor until the fastener axis and bolt tester axis are in alignment
3. Adjust the length of the threaded legs until the head of the bolt tester adaptor can be passed through the opening in the load spreading bridge. Check that the head of the load spreading bridge is centered in the tester and the button adaptor is square in the u shaped slot in the puller. Make final adjustments so that the bolt tester adaptor, tester and fixing are aligned
4. Position the tester so that the gauge can be easily read
5. Adjust the length of the threaded legs so that all three are in contact with the base material and the load spreading bridge is aligned and level by referring to the bubble levels on each face
6. Set the red pointer on the gauge to zero – hold the tester by the grip handle and proceed to load the fastener by turning the operating handle clockwise
7. Increase the load until the required test load is attained. Hold this load and observe any falling back of the gauge pointer which would indicate movement and possible failure of the fastener. Record the satisfactory result
8. Release the load on the fastener by turning the operating handle anti-clockwise and allowing the test jaw to return to the original position
9. Remove the tester and bolt tester adaptor

I[⊗]RAWLPLUG[®]
Trust & Innovation

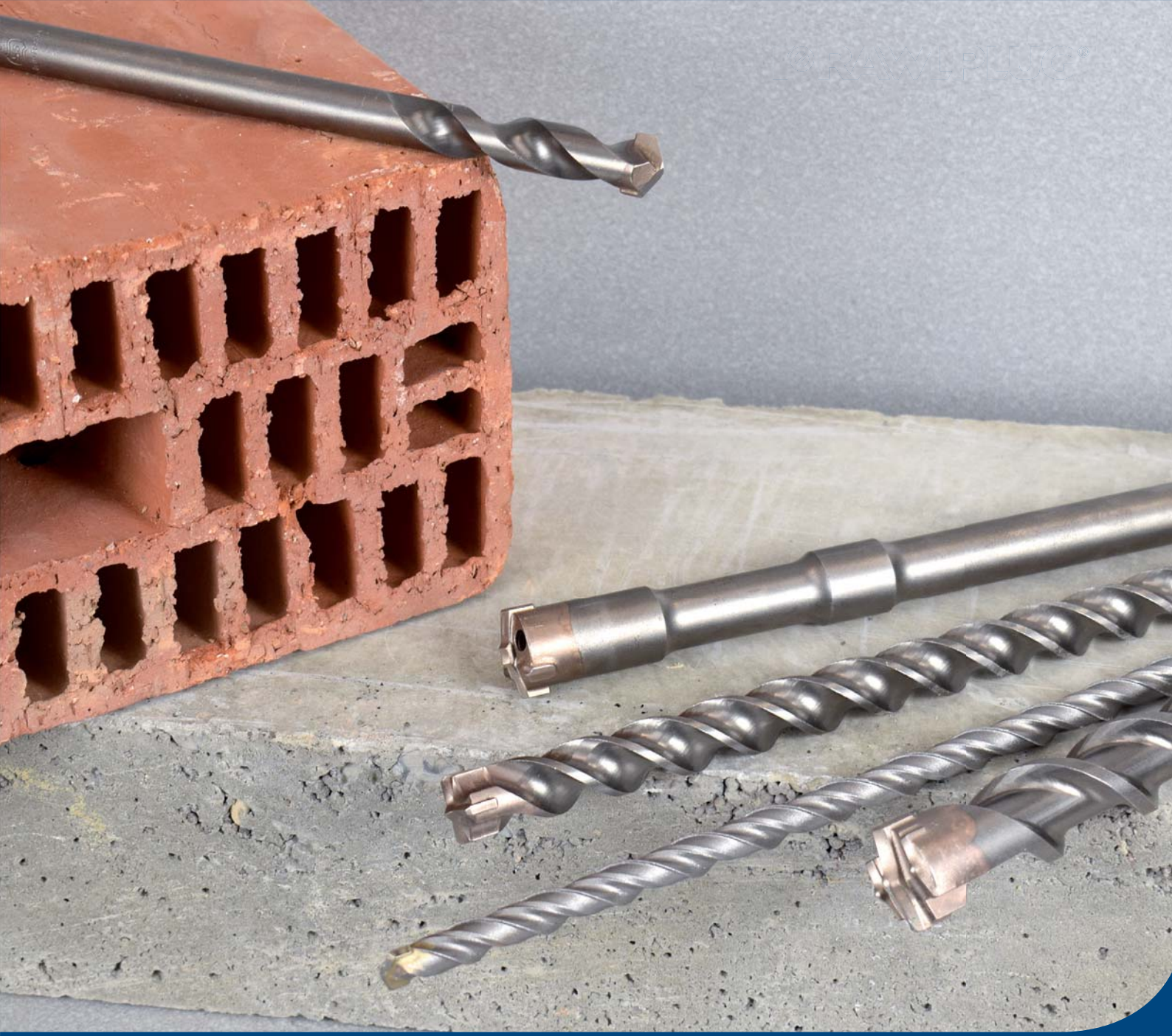

Power Tool Accessories

DRILL BITS

- RT-SDSA Aggressor SDS plus
- RT-SDSR Rebar-drill SDS plus
- RT-SDSB Brick-drill SDS plus
- RT-SDSH Dustless-drill SDS plus
- RT-MAXA Aggressor SDS max
- RT-MAXR Rebar-drill SDS max
- RT-MAXT Turbodrill SDS max
- RT-MAXH Dustless-drill SDS max



RT-SDSA Aggressor SDS plus

Drill bits for fast drilling in concrete AGGRESSOR SDS plus



Certificate



Product overview

Features and benefits

- Self-aligning drill bit tip enables quick and easy start drilling at the marked spot
- Increased angle plates to 160° results in faster drilling in concrete
- Very deep seating of carbide plate significantly increases the durability of the connection to the core drill which improves the quality of the drill
- Aggressive flutes increase dust extraction and accelerate drilling
- Steel on the specification of 34CrNiMo6 provides high resistance and durability
- Subjected to a heat treatment by which the hardness of the steel increases to 52 HRC for optimal resistance during drilling
- Drilling speed increased by 30%
- Extremely high durability confirmed by the international certificate SicherSafe

Applications

- Drilling in concrete, brick and stone
- Suitable for use with SDS plus Rotary Hammer

Base materials

For use in:

- Concrete
- Solid Brick
- Hollow Brick
- Natural Stone
- Aerated Concrete Block

Packaging

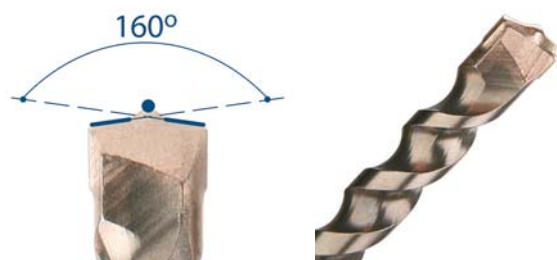

Product Commercial Data

Product Code	Description			Logistic data		Bar Code
	Diameter	Length		Quantity	Weight	
	Ø	L	L1			
[mm]						
RT-SDSA-4/110	4	110	50	1	0.0377	5906675114767
RT-SDSA-5/110	5	110	50	1	0.0395	5906675114774
RT-SDSA-5/160	5	160	100	1	0.039	5906675027944
RT-SDSA-5/160B12	5	160	100	1	0.042	5906675335247
RT-SDSA-5/210	5	210	150	1	0.036	5906675114781
RT-SDSA-5/310	5	310	250	1	0.064	5906675063461
RT-SDSA-5/310B12	5	310	250	12	0.760	5906675063478
RT-SDSA-5/460	5	460	400	1	0.077	5906675114798
RT-SDSA-55/110	5.5	110	50	1	0.036	5906675422947
RT-SDSA-55/160	5.5	160	100	1	0.041	5906675026503
RT-SDSA-55/260	5.5	260	100	1	0.06	5906675114804
RT-SDSA-55/310	5.5	310	250	1	0.06	5906675114811
RT-SDSA-55/460	5.5	460	400	1	0.09	5906675114828
RT-SDSA-6/110	6	110	50	1	0.037	5906675027920
RT-SDSA-6/160	6	160	100	1	0.045	5906675026589
RT-SDSA-6/160B12	6	160	100	12	0.57	5906675063539
RT-SDSA-6/210	6	210	150	1	0.045	5906675027982
RT-SDSA-6/210B12	6	260	200	1	0.054	5906675335605
RT-SDSA-6/260	6	260	200	1	0.100	5906675048598
RT-SDSA-6/310B12	6	310	250	12	0.884	5906675063485
RT-SDSA-6/360	6	360	300	1	0.080	5906675387093
RT-SDSA-6/460	6	460	400	1	0.090	5906675114835
RT-SDSA-65/110	6.5	110	50	1	0.038	5906675422954
RT-SDSA-65/160	6.5	160	100	1	0.046	5906675422961
RT-SDSA-65/210	6.5	210	150	1	0.0578	5906675114842
RT-SDSA-65/260	6.5	260	200	1	0.061	5906675114859
RT-SDSA-65/310	6.5	310	250	1	0.071	5906675114866
RT-SDSA-7/110	7	110	50	1	0.039	5906675026572
RT-SDSA-7/160	7	160	100	1	0.049	5906675026565
RT-SDSA-8/1000	8	1000	940	1	0.268	5906675335261
RT-SDSA-8/110	8	110	50	1	0.043	5906675026558
RT-SDSA-8/160	8	160	100	1	0.056	5906675027951
RT-SDSA-8/160B12	8	160	100	12	0.679	5906675063546
RT-SDSA-8/210	8	210	150	1	0.068	5906675027968
RT-SDSA-8/210B12	8	210	150	12	0.069	5906675335612
RT-SDSA-8/260	8	260	200	1	0.068	5906675027937
RT-SDSA-8/260B12	8	260	200	1	0.082	5906675335636
RT-SDSA-8/310	8	310	250	1	0.077	5906675027975
RT-SDSA-8/310B12	8	310	250	12	0.970	5906675063508
RT-SDSA-8/360	8	360	300	1	0.1073	5906675387109
RT-SDSA-8/410	8	410	350	1	0.300	5906675114873
RT-SDSA-8/460	8	460	400	1	0.1497	5906675114880
RT-SDSA-9/160	9	160	100	1	0.0711	5906675114897
RT-SDSA-95/410	9.5	410	350	1	0.300	5906675045993
RT-SDSA-10/110	10	110	50	1	0.051	5906675026596
RT-SDSA-10/160	10	160	100	1	0.069	5906675026602
RT-SDSA-10/160B12	10	160	100	12	1.000	5906675063553
RT-SDSA-10/210	10	210	150	1	0.09	5906675026619
RT-SDSA-10/210B12	10	210	150	12	0.087	5906675335612
RT-SDSA-10/260	10	260	200	1	0.077	5906675026626
RT-SDSA-10/260B12	10	260	200	12	1.000	5906675335636
RT-SDSA-10/310	10	310	250	1	0.077	5906675028002
RT-SDSA-10/310B12	10	310	250	12	1.000	5906675063515
RT-SDSA-10/360	10	360	300	1	0.1400	5906675387116
RT-SDSA-10/410	10	410	350	1	0.1570	5906675335285

Product Commercial Data

Product Code	Description			Logistic data		Bar Code
	Diameter	Length		Quantity	Weight	
	∅	L	L1			
	[mm]			[szt.]	[kg]	
RT-SDSA-10/460	10	460	400	1	0.1996	5906675114910
RT-SDSA-10/610	10	610	550	1	0.2614	5906675114927
RT-SDSA-10/1000	10	1000	940	1	0.4549	5906675114934
RT-SDSA-11/260	11	260	200	1	0.123	5906675086156
RT-SDSA-11/310	11	310	250	1	0.147	5906675086163
RT-SDSA-11/410	11	410	350	1	0.191	5906675086811
RT-SDSA-12/160	12	160	100	1	0.089	5906675026633
RT-SDSA-12/210	12	210	150	1	0.112	5906675026640
RT-SDSA-12/260	12	260	200	1	0.077	5906675028019
RT-SDSA-12/310	12	310	250	1	0.168	5906675026657
RT-SDSA-12/410	12	410	350	1	0.228	5906675335292
RT-SDSA-12/460	12	460	400	1	0.408	5906675086149
RT-SDSA-12/610	12	610	550	1	0.3312	5906675114958
RT-SDSA-12/1000	12	1000	940	1	0.540	5906675114965
RT-SDSA-13/210	13	210	150	1	0.138	5906675389806
RT-SDSA-13/260	13	260	200	1	0.172	5906675389813
RT-SDSA-14/160	14	160	100	1	0.1096	5906675114972
RT-SDSA-14/210	14	210	150	1	0.131	5906675026664
RT-SDSA-14/260	14	260	200	1	0.167	5906675026671
RT-SDSA-14/310	14	310	250	1	0.199	5906675026688
RT-SDSA-14/460	14	460	400	1	0.250	5906675026695
RT-SDSA-14/610	14	610	550	1	0.3804	5906675115009
RT-SDSA-14/1000	14	1000	940	1	0.624	5906675115047
RT-SDSA-15/160	15	160	100	1	0.1371	5906675115054
RT-SDSA-15/210	15	210	150	1	0.173	5906675086828
RT-SDSA-16/160	16	160	100	1	0.1379	5906675115054
RT-SDSA-16/210	16	210	150	1	0.1771	5906675115078
RT-SDSA-16/260	16	260	200	1	0.207	5906675026701
RT-SDSA-16/310	16	310	250	1	0.255	5906675026718
RT-SDSA-16/460	16	460	400	1	0.302	5906675026725
RT-SDSA-16/610	16	610	550	1	0.4996	5906675115085
RT-SDSA-16/1000	16	1000	940	1	0.880	5906675115092
RT-SDSA-18/210	18	210	150	1	0.217	5906675115108
RT-SDSA-18/260	18	260	200	1	0.2833	5906675115115
RT-SDSA-18/310	18	310	250	1	0.315	5906675026732
RT-SDSA-18/460	18	460	400	1	0.413	5906675026749
RT-SDSA-18/610	18	610	550	1	0.679	5906675115139
RT-SDSA-18/1000	18	1000	940	1	1.105	5906675115146
RT-SDSA-20/210	20	210	150	1	0.280	5906675422978
RT-SDSA-20/310	20	310	250	1	0.399	5906675026756
RT-SDSA-20/460	20	460	400	1	0.529	5906675026763
RT-SDSA-20/610	20	610	550	1	0.793	5906675115153
RT-SDSA-20/1000	20	1000	940	1	1.200	5906675423005
RT-SDSA-22/310	22	310	250	1	0.440	5906675335308
RT-SDSA-22/460	22	460	400	1	0.640	5906675026770
RT-SDSA-24/310	24	310	250	1	0.490	5906675335315
RT-SDSA-24/460	24	460	400	1	0.735	5906675026787
RT-SDSA-25/310	25	310	250	1	0.9567	5906675115238
RT-SDSA-25/460	25	460	400	1	0.9567	5906675115245
RT-SDSA-26/460	26	460	400	1	0.866	5906675026794
RT-SDSA-30/460	30	460	400	1	1.100	5906675115252

RT-SDSR Rebar drill SDS plus

High quality drill bits for reinforced concrete REBARDRILL SDS plus



Certificate



Product overview

Features and benefits

- The monolithic carbide plate greatly increases the life of the drill
- Self-aligning drill bit tip enables quick and easy start drilling at the marked spot
- 3 symmetrical points of contact of the drill bit with the substrate allows drilling perfectly straight and cylindrical holes
- Suitable Approach angle Plate 135° allows for drilling in reinforced concrete
- Very deep seating of carbide plate significantly increases the durability of the connection to the core drill which improves the quality of the drill
- 3 areas of dust extraction and special shape make it easy to remove the dust
- Steel on the specification of 34CrNiMo6 provides high resistance and durability
- Subjected to a heat treatment by which the hardness of the steel increases to 52 HRC for optimal resistance during drilling
- Drilling without damage the substrate even near edges

Applications

- Drilling in reinforced concrete and hard brick
- Suitable for use with SDS plus Rotary Hammer

Base materials

For use in:

- Reinforced concrete
- Concrete
- Natural Stone
- Solid Concrete Block
- Solid Brick

Packaging

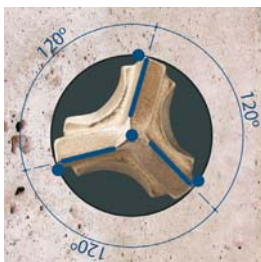

Product Commercial Data

Product Code	Description			Logistic data		Bar Code
	Diameter	Length		Quantity	Weight	
	∅	L	L1			
	[mm]			[szt.]	[kg]	
RT-SDSR-5/110	5	110	50	1	0.0395	5906675115269
RT-SDSR-5/160	5	160	100	1	0.041	5906675046006
RT-SDSR-5/160B12	5	160	100	12	0.040	5906675335322
RT-SDSR-5/210	5	210	150	1	0.047	5906675115276
RT-SDSR-5/360	5	360	300	1	0.070	5906675387123
RT-SDSR-6/110	6	110	50	1	0.042	5906675047713
RT-SDSR-6/160	6	160	100	1	0.049	5906675046013
RT-SDSR-6/160B12	6	160	100	12	0.570	5906675063560
RT-SDSR-6/210	6	210	150	1	0.056	5906675046020
RT-SDSR-6/260	6	260	200	1	0.065	5906675046037
RT-SDSR-6/310	6	310	250	1	0.063	5906675335346
RT-SDSR-6/310B12	6	310	250	12	0.884	5906675063591
RT-SDSR-6/360	6	360	300	1	0.080	5906675387130
RT-SDSR-7/160	7	160	100	1	0.051	5906675047737
RT-SDSR-8/110	8	110	50	1	0.047	5906675047720
RT-SDSR-8/160	8	160	100	1	0.059	5906675046044
RT-SDSR-8/160B12	8	160	100	12	0.679	5906675063577
RT-SDSR-8/210	8	210	150	1	0.07	5906675046051
RT-SDSR-8/260	8	260	200	1	0.082	5906675046068
RT-SDSR-8/310	8	310	250	1	0.095	5906675046075
RT-SDSR-8/310B12	8	310	250	12	11.64	5906675063607
RT-SDSR-8/360	8	360	300	1	0.1073	5906675387147
RT-SDSR-8/460	8	460	400	1	0.130	5906675046082
RT-SDSR-10/110	10	110	50	1	0.051	5906675335353
RT-SDSR-10/160	10	160	100	1	0.076	5906675046099
RT-SDSR-10/160B12	10	160	100	12	1.000	5906675063584
RT-SDSR-10/210	10	210	150	1	0.094	5906675046105
RT-SDSR-10/260	10	260	200	1	0.113	5906675046112
RT-SDSR-10/260B12	10	260	200	12	0.110	5906675335414
RT-SDSR-10/310	10	310	250	1	0.132	5906675046136
RT-SDSR-10/310B12	10	310	250	12	12.00	5906675063614
RT-SDSR-10/360	10	360	300	1	0.140	5906675387154
RT-SDSR-10/460	10	460	400	1	0.300	5906675046143
RT-SDSR-12/160	12	160	100	1	0.093	5906675046150
RT-SDSR-12/210	12	210	150	1	0.117	5906675046167
RT-SDSR-12/260	12	260	200	1	0.139	5906675046174
RT-SDSR-12/310	12	310	250	1	0.162	5906675046181
RT-SDSR-12/460	12	460	400	1	0.234	5906675046198
RT-SDSR-14/210	14	210	150	1	0.135	5906675046204
RT-SDSR-14/260	14	260	200	1	0.161	5906675046211
RT-SDSR-14/310	14	310	250	1	0.188	5906675046228
RT-SDSR-14/460	14	460	400	1	0.277	5906675046235
RT-SDSR-15/160	15	160	100	1	0.129	5906675335360
RT-SDSR-15/210	15	210	150	1	0.162	5906675335377
RT-SDSR-16/160	16	160	100	1	0.13	5906675335391
RT-SDSR-16/210	16	210	150	1	0.154	5906675046242
RT-SDSR-16/260	16	260	200	1	0.184	5906675046259
RT-SDSR-16/310	16	310	250	1	0.211	5906675046266
RT-SDSR-16/460	16	460	400	1	0.313	5906675046273
RT-SDSR-18/210	18	210	150	1	0.223	5906675335407
RT-SDSR-18/310	18	310	250	1	0.264	5906675046280
RT-SDSR-20/310	20	310	250	1	0.324	5906675046297
RT-SDSR-20/460	20	460	400	1	0.547	5906675071183

RT-SDSB Brickdrill SDS plus

Drill bits for fast drilling in ceramic materials without damage BRICKDRILL SDS plus

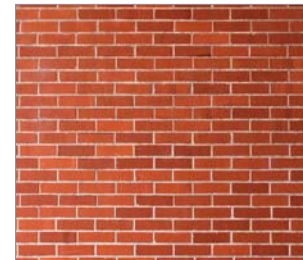

Certificate



Product overview

Features and benefits

- Tip angle 120° allows for fast drilling of holes in ceramic material without damage
- Short drill bit flute accelerates dust extraction between the slots of ceramic brick
- Drilling without hammering
- Perfect straight hole without damaging the ceramic brick
- Steel on the specification of 34CrNiMo6 provides high resistance and durability
- Subjected to a heat treatment by which the hardness of the steel increases to 52 HRC for optimal resistance during drilling
- Also suitable for aerated concrete
- Long drill bit shank allows to drill deep holes also by insulation
- Extremely high durability confirmed by the international certificate SicherSafe

Applications

- Drilling in ceramic hollow bricks
- Suitable for use with SDS plus Rotary Hammer

Base materials

For use in:

- Hollow Brick
- Aerated Concrete Block

Packaging



Product Commercial Data

Product Code	Description			Logistic data		Bar Code
	Diameter	Length		Quantity	Weight	
	∅	L	L1			
	[mm]			[szt.]	[kg]	
RT-SDSB-6/260	8	260	200	1	0.070	5906675046303
RT-SDSB-8/260	8	260	200	1	0.095	5906675046310
RT-SDSB-8/310	8	310	250	1	0.113	5906675047553
RT-SDSB-8/460	8	460	400	1	0.200	5906675048918
RT-SDSB-10/260	10	260	200	1	0.291	5906675046334
RT-SDSB-10/310	10	310	250	1	0.156	5906675047560
RT-SDSB-10/460	10	460	400	1	0.200	5906675048604
RT-SDSB-12/260	12	260	200	1	0.167	5906675046341
RT-SDSB-15/260	15	260	200	1	0.248	5906675046358
RT-SDSB-16/260	16	260	200	1	0.247	5906675046365

RT-SDSH Hollow drill bits Dustlessdrill SDS plus

Hollow drill bits SDS plus for dust-free drilling in concrete

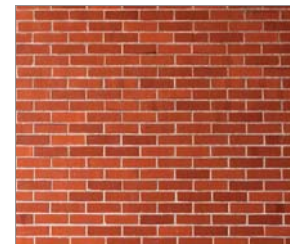

Certificate



Product overview

Features and benefits

- Two holes in the tip of the drill bit allows you to drill and extract dust simultaneously (due to the possibility of fastening a vacuum cleaner)
- Drilling, along with dust extraction, make the hole smooth and clean
- Quick removal of dust increases drilling speed and enhances drill bit durability (reduces friction)
- Drilled holes do not require cleaning before fastening, which greatly reduces assembly time
- Centring point for quick commencement of drilling without the drill slipping
- Very deep seating of carbide plate significantly improves connection with the drill core, which affects quality

Applications

- Drilling holes in reinforced concrete, concrete, stone and hard brick

Base materials

- Concrete
- Solid Brick
- Solid Concrete Block

Packaging



NEW

Commercial product data

Index	Drill diameter	Length	Working length	Quantity	Box weight	Outer weight	EAN
	[mm]	[mm]	[mm]	[pcs]	kg	kg	
RT-SDSH-8/270	8	270	150	1	0.22	1.10	5906675397184
RT-SDSH-10/270	10	270	150	1	0.25	1.25	5906675397191
RT-SDSH-12/320	12	320	200	1	0.31	1.56	5906675397207
RT-SDSH-14/370	14	370	250	1	0.39	1.95	5906675397214
RT-SDSH-15/370	15	370	250	1	0.50	2.48	5906675397221
RT-SDSH-16/370	16	370	250	1	0.43	2.17	5906675397238
RT-SDSH-18/370	18	370	250	1	0.53	2.63	5906675397245
RT-SDSH-20/370	20	370	250	1	0.62	3.11	5906675397252
RT-SDSH-24/370	24	370	250	1	1.00	5.00	5906675397269

All products listed in this publication are branded and distributed with RAWLPLUS® or RAWL® trademarks.

RT-MAXH Hollow drill bits Dustlessdrill SDS max

Hollow drill bits SDS max for dust-free drilling in reinforced concrete



Certificate



Product overview

Features and benefits

- Two holes in the tip of the drill bit allows you to drill and extract dust simultaneously (due to the possibility of fastening a vacuum cleaner)
- Drilling, along with dust extraction, make the hole smooth and clean
- Quick removal of dust increases drilling speed and enhances drill bit durability (reduces friction)
- Drilled holes do not require cleaning before fastening, which greatly reduces assembly time
- Rubber adapter, which is built-in the bit, enables you to fasten a vacuum cleaner hose and to drill holes without dust

Applications

- Drilling holes in reinforced concrete, concrete, stone and hard brick

Base materials

- Reinforced concrete
- Concrete
- Solid Brick
- Solid Concrete Block

Packaging



Commercial product data

Index	Drill diameter	Length	Working length	Quantity	Box weight	Outer weight	EAN
	[mm]	[mm]	[mm]	[pcs]	kg	kg	
RT-MAXH-14/600	14	600	400	1	0.82	4.11	5906675397085
RT-MAXH-16/600	16	600	400	1	0.92	4.59	5906675397092
RT-MAXH-18/600	18	600	400	1	0.99	4.97	5906675397108
RT-MAXH-20/600	20	600	400	1	1.13	5.64	5906675397115
RT-MAXH-22/600	22	600	400	1	1.13	5.64	5906675397122
RT-MAXH-25/600	25	600	400	1	1.12	5.62	5906675397139
RT-MAXH-28/600	28	600	400	1	1.29	6.44	5906675397146
RT-MAXH-30/600	30	600	400	1	1.44	7.18	5906675397153
RT-MAXH-32/600	32	600	400	1	1.48	7.40	5906675397160
RT-MAXH-35/600	35	600	400	1	1.59	7.93	5906675397177

RT-MAXA Aggressor SDS max

High quality AGGRESSOR SDS MAX drill bits for reinforced concrete



Certificate



Product overview

Features and benefits

- 3 deep seeting cabide plates greatly increase the life of the drill
- 6 cutting edges increase the drilling efficiency and accelerates the execution of holes
- 3 self-aligning points allow drilling in reinforced concrete even when it hits the side of the rebar
- Optimized geometry of drill bit body allows to make axial and cylindrical holes ideal for fixing
- Steel on the specification of 34CrNiMo6 provides high resistance and durability
- Subjected to a heat treatment by which the hardness of the steel increases to 52 HRC for optimal resistance during drilling
- Drill bit core subjected to special thermal treatment which increases flexibility, resistance to twisting and the possibility of breaking
- Extremely high durability confirmed by the international certificate SicherSafe

Applications

- Drilling in reinforced concrete and hard brick
- Suitable for use with SDS max Rotary Hammer

Base materials

For use in:

- Reinforced concrete
- Concrete
- Natural Stone
- Solid Brick
- Solid Concrete Block

Packaging



Product Commercial Data

Product Code	Description			Logistic data		Bar Code
	Diameter	Length		Quantity	Weight	
	Ø	L	L1			
	[mm]			[szt.]	[kg]	
RT-MAXA-12/340	12	340	200	1	0.382	5906675115283
RT-MAXA-12/540	12	540	400	1	0.477	5906675115573
RT-MAXA-14/340	14	340	200	1	0.403	5906675116228
RT-MAXA-14/540	14	540	400	1	0.593	5906675116235
RT-MAXA-15/340	15	340	200	1	0.441	5906675335438
RT-MAXA-15/540	15	540	400	1	0.593	5906675335445
RT-MAXA-16/340	16	340	200	1	0.441	5906675025933
RT-MAXA-16/540	16	540	400	1	0.593	5906675026367
RT-MAXA-18/340	16	340	200	1	0.501	5906675026374
RT-MAXA-18/540	18	540	400	1	0.718	5906675026381
RT-MAXA-20/340	20	340	200	1	0.548	5906675026398
RT-MAXA-20/540	20	540	400	1	0.819	5906675026404
RT-MAXA-20/690	20	690	550	1	1.038	5906675335476
RT-MAXA-20/920	20	920	780	1	1.113	5906675116242
RT-MAXA-22/340	22	340	200	1	0.600	5906675026411
RT-MAXA-22/540	22	540	400	1	0.934	5906675026428
RT-MAXA-22/920	22	920	780	1	1.603	5906675116341
RT-MAXA-24/340	24	340	200	1	0.669	5906675026435
RT-MAXA-24/540	24	540	400	1	1.05	5906675026442
RT-MAXA-24/690	24	690	550	1	1.312	5906675335506
RT-MAXA-24/920	24	920	780	1	1.872	5906675335513
RT-MAXA-25/340	25	340	200	1	0.735	5906675116358
RT-MAXA-25/540	25	340	400	1	1.144	5906675026459
RT-MAXA-25/690	25	690	550	1	1.495	5906675335537
RT-MAXA-25/920	25	920	780	1	1.786	5906675116365
RT-MAXA-26/340	26	340	200	1	0.735	5906675116372
RT-MAXA-26/540	26	540	400	1	1.176	5906675116389
RT-MAXA-26/690	26	690	550	1	1.333	5906675335544
RT-MAXA-26/920	26	920	780	1	2.205	5906675335551
RT-MAXA-28/340	28	340	200	1	0.829	5906675116396
RT-MAXA-28/540	28	540	400	1	1.334	5906675026466
RT-MAXA-28/690	28	690	550	1	1.692	5906675116402
RT-MAXA-28/920	28	920	780	1	2.436	5906675335568
RT-MAXA-30/340	30	340	200	1	0.873	5906675116419
RT-MAXA-30/540	30	540	400	1	1.472	5906675026473
RT-MAXA-30/690	30	690	550	1	1.890	5906675335575
RT-MAXA-30/920	30	920	780	1	2.616	5906675116457
RT-MAXA-32/340	32	340	200	1	0.880	5906675116440
RT-MAXA-32/540	32	540	400	1	1.480	5906675026480
RT-MAXA-32/920	32	920	780	1	2.768	5906675116457
RT-MAXA-35/340	35	340	200	1	0.965	5906675116501
RT-MAXA-35/540	35	540	400	1	1.550	5906675071190
RT-MAXA-35/690	35	690	550	1	2.100	5906675116518
RT-MAXA-36/540	36	540	400	1	1.945	5906675116525
RT-MAXA-38/340	38	340	200	1	1.100	5906675116532
RT-MAXA-38/540	38	540	400	1	1.742	5906675116549
RT-MAXA-38/690	38	690	550	1	2.330	5906675116563
RT-MAXA-40/540	40	540	400	1	2.008	5906675071206
RT-MAXA-40/920	40	920	780	1	3.806	5906675116624
RT-MAXA-42/540	42	540	400	1	2.018	5906675071213
RT-MAXA-45/540	45	540	400	1	2.284	5906675116648

RT-MAXR Rebar drill SDS max

NEW

System of extensions and connector SDS max allows drilling deep holes

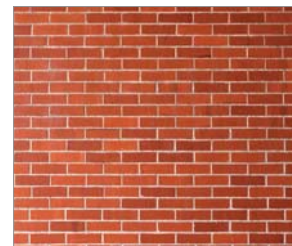

Certificate



Product overview

Features and benefits

- Monolithic carbide tip increases the life of the drill bit
- Centring point for quick commencement of drilling without the drill slipping
- 3 symmetrically arranged cutting edges allow for perfectly straight and axial drilling
- Angle tip 135° allows drilling in reinforced concrete
- Very deep seating of carbide plate significantly improves connection with the drill core, which affects quality
- 3 material extraction surfaces and special shape of the drill facilitate the removal of dust
- Steel with specification 34CrNiMo6 provides high strength and durability
- Heat treated, which increases the hardness of the steel to 52 HRC for optimal resistance during operation
- Extremely high quality, cylindricity and axial alignment of drilled holes, confirmed by international Sicher Safe certificate

Applications

- Drilling holes in reinforced concrete, concrete, stone and hard brick
- Suitable for operation with SDS plus hammer drill

Base materials

- Reinforced concrete
- Concrete
- Natural Stone
- Solid Concrete Block
- Solid Brick

Packaging



Product Commercial Data

Product Code	Drill diameter	Length	Working length	Quantity	Box weight	Outer weight	Bar Code
	[mm]			[pcs]	[kg]	[kg]	
RT-MAXR-12/340	12	340	200	1	0.38	19.10	5906675416762
RT-MAXR-12/540	12	540	400	1	0.48	19.08	5906675416779
RT-MAXR-14/540	14	540	400	1	0.40	20.15	5906675416793
RT-MAXR-15/340	15	340	200	1	0.44	22.05	5906675416809
RT-MAXR-15/540	15	540	400	1	0.59	17.79	5906675416816
RT-MAXR-16/340	16	340	200	1	0.44	22.05	5906675416823
RT-MAXR-16/540	16	540	400	1	0.59	17.79	5906675416830
RT-MAXR-18/340	18	340	200	1	0.50	20.04	5906675416847
RT-MAXR-18/540	18	540	400	1	0.72	21.54	5906675416854
RT-MAXR-20/340	12	340	200	1	0.55	21.92	5906675416861
RT-MAXR-20/540	20	540	400	1	0.82	20.48	5906675416878

RT-MAXT Turbodrill SDS max

NEW

SDS max drill for drilling deep holes in reinforced concrete, concrete, stone and hard brick

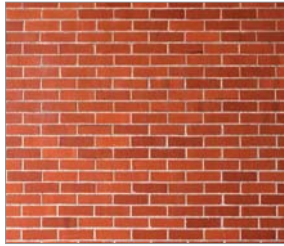

Certificate



Product overview

Features and benefits

- 3 deep-set carbide plates significantly increase the service life and efficiency of the drill
- Steel with specification 34CrNiMo6 provides high strength and durability
- Extremely high quality, cylindricity and axial alignment of drilled holes, confirmed by international SicherSafe certificate
- Optimized drill geometry allows making axial and cylindrical holes, perfect for mounting
- Heat treated, which increases the hardness of the steel to 52 HRC for optimal resistance during operation
- The drill core is subjected to special heat treatment, which increases its flexibility, resistance to twisting and prevents breaking

Applications

- Drilling holes in reinforced concrete, concrete, stone and hard brick

Base materials

- Reinforced concrete
- Concrete
- Natural Stone
- Solid Concrete Block
- Solid Brick

Packaging



All products listed in this publication are branded and distributed with RAWLPLUG® or RAWL® trademarks.

Product Commercial Data

Product Code	Drill diameter	Length	Working length	Quantity	Box weight	Outer weight	Bar Code
		[mm]		[pcs]	[kg]	[kg]	
RT-MAXT-12/340	12	340	200	1	0.38	19.10	5906675416168
RT-MAXT-12/540	12	540	400	1	0.48	19.08	5906675416175
RT-MAXT-14/340	14	340	200	1	0.40	12.09	5906675416182
RT-MAXT-14/540	14	540	400	1	0.59	29.65	5906675416199
RT-MAXT-15/340	15	340	200	1	0.44	17.64	5906675416205
RT-MAXT-15/540	15	540	400	1	0.59	17.79	5906675416212
RT-MAXT-16/340	16	340	200	1	0.44	13.23	5906675416229
RT-MAXT-16/540	16	540	400	1	0.59	29.65	5906675416236
RT-MAXT-16/690	16	690	550	1	0.70	21.03	5906675416243
RT-MAXT-18/340	18	340	200	1	0.50	10.04	5906675416250
RT-MAXT-18/540	8	540	400	1	0.72	28.72	5906675416267
RT-MAXT-18/690	18	690	550	1	0.89	26.58	5906675416274
RT-MAXT-20/340	20	340	200	1	0.55	21.92	5906675416298
RT-MAXT-20/540	20	540	400	1	0.82	20.48	5906675416304
RT-MAXT-20/690	20	690	550	1	1.04	31.14	5906675416311
RT-MAXT-22/540	22	540	400	1	0.93	23.35	5906675416359
RT-MAXT-22/690	22	690	550	1	1.17	23.40	5906675416366
RT-MAXT-24/340	24	340	200	1	0.67	20.10	5906675416380
RT-MAXT-24/540	24	540	400	1	1.05	21.00	5906675416397
RT-MAXT-24/690	24	690	550	1	1.31	26.24	5906675416403
RT-MAXT-25/340	25	340	200	1	0.74	22.05	5906675416434
RT-MAXT-25/540	25	540	400	1	1.14	22.88	5906675416441
RT-MAXT-25/690	25	690	550	1	1.50	29.90	5906675416458
RT-MAXT-26/340	26	340	200	1	0.74	22.05	5906675416472
RT-MAXT-26/540	26	540	400	1	1.18	23.52	5906675416489
RT-MAXT-26/690	26	690	550	1	1.33	13.33	5906675416496
RT-MAXT-28/340	28	340	200	1	0.83	20.73	5906675416519
RT-MAXT-28/540	28	540	400	1	1.20	17.93	5906675416533
RT-MAXT-28/690	28	690	550	1	1.69	16.92	5906675416540
RT-MAXT-30/340	30	340	200	1	0.87	21.83	5906675416564
RT-MAXT-30/540	30	540	400	1	1.34	20.03	5906675416571
RT-MAXT-30/690	30	690	550	1	1.89	18.90	5906675416588
RT-MAXT-32/340	32	340	200	1	0.88	22.00	5906675416601
RT-MAXT-32/540	32	540	400	1	1.47	21.98	5906675416618
RT-MAXT-35/340	35	340	200	1	0.97	19.30	5906675416649
RT-MAXT-35/540	35	540	400	1	1.96	29.34	5906675416656
RT-MAXT-35/690	35	690	550	1	2.10	21.00	5906675416663
RT-MAXT-36/540	36	540	400	1	1.95	19.45	5906675416670
RT-MAXT-38/340	38	340	200	1	1.10	22.00	5906675416687
RT-MAXT-38/540	38	540	400	1	1.74	17.42	5906675416694
RT-MAXT-38/690	38	690	550	1	2.33	23.30	5906675416700
RT-MAXT-40/540	40	540	400	1	2.00	11.97	5906675416731
RT-MAXT-42/540	42	540	400	1	2.28	22.83	5906675416755
RT-MAXT-45/540	45	540	400	1	2.28	22.84	5906675424613

RT-BIT-PH Phillips screwdriver bits

Phillips screwdriver bits with precision milled head



Product overview

Features and benefits

- Special steel S2 affects the life of the product
- Specially heat treated in the hardening process to increase the hardness of the tip to 60 HRC
- Precision milled head tip allows for precise fitting into the screw socket
- The special shape of the tip increases its resistance to twisting under the so-called torsion effect
- Anticorrosion coating, blue colour, prevents rust

Applications

- Screwdriving of Phillips screws for wood and drywall

Packaging



Commercial product data

Index	Size	Length	Quantity	Box weight	Outer weight	Bar Code
		[mm]	[pcs]	kg	kg	
RT-BIT-PH1/25	PH1	25	20	0.30	3.00	5906675034942
RT-BIT-PH2/25	PH2	25	20	0.30	3.00	5906675034959
RT-BIT-PH2/50	PH2	50	10	0.30	3.00	5906675035031
RT-BIT-PH3/25	PH3	25	20	0.30	3.00	5906675034966
RT-BIT-PH1X3	PH1	25	3	0.024	0.24	5906675072289
RT-BIT-PH2X3	PH2	25	3	0.024	0.24	5906675072296
RT-BIT-PH3X3	PH3	25	3	0.024	0.24	5906675072302
RT-BIT-PH123	PH1 PH2 PH3	25	3	0.024	0.24	5906675072395

All products listed in this publication are branded and distributed with RAWLPLUG® or RAWL® trademarks.

RT-BIT-PZ Pozidriv screwdriver bits

Pozidriv screwdriver bits with precision milled head

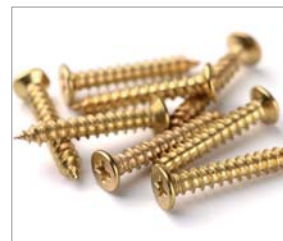

Product overview

Features and benefits

- Special steel S2 affects the life of the product
- Specially heat treated in the hardening process to increase the hardness of the tip to 60 HRC
- Precision milled head tip allows for precise fitting into the screw socket
- The special shape of the tip increases its resistance to twisting under the so-called torsion effect
- Anticorrosion coating, blue colour, prevents rust

Applications

- Screwdriving of Pozidriv screws, a wide range of applications in wood and light mountings

Packaging



Commercial product data

Index	Size	Length	Quantity	Box weight	Outer weight	Bar Code
		[mm]	[pcs]	kg	kg	
RT-BIT-PZ1/25	PZ1	25	20	0.30	3.00	5906675034973
RT-BIT-PZ2/25	PZ2	25	20	0.30	3.00	5906675034980
RT-BIT-PZ2/50	PZ2	50	10	0.30	3.00	5906675035048
RT-BIT-PZ3/25	PZ3	25	20	0.30	3.00	5906675038018
RT-BIT-PZ1X3	PZ1	25	3	0.024	0.24	5906675072319
RT-BIT-PZ2X3	PZ2	25	3	0.024	0.24	5906675072333
RT-BIT-PZ3X3	PH3	25	3	0.024	0.24	5906675072340
RT-BIT-PZ123	PZ1 PZ2 PZ3	25	3	0.024	0.24	5906675072401

RT-BIT-TORX T type screwdriver bits

T type screwdriver bits with precision milled head



Product overview

Features and benefits

- Special steel S2 affects the life of the product
- Specially heat treated in the hardening process to increase the hardness of the tip to 60 HRC
- Precision milled head tip allows for precise fitting into the screw socket
- The special shape of the tip increases its resistance to twisting under the so-called torsion effect
- Anticorrosion coating, blue colour, prevents rust

Applications

- Screwdriving of T type screws for wood, metal and concrete

Packaging



Commercial product data

Index	Size	Length	Quantity	Box weight	Outer weight	Bar Code
		[mm]	[pcs]	kg	kg	
RT-BIT-TORX10/25	T10	25	20	0.3	3.00	5906675335858
RT-BIT-TORX10X3	T10	25	3	0.24	0.24	5906675406176
RT-BIT-TORX15/25	T15	25	20	0.3	3.00	5906675335865
RT-BIT-TORX15X3	T15	25	3	0.024	0.24	5906675406183
RT-BIT-TORX20/25	T20	25	20	0.3	3.00	5906675335872
RT-BIT-TORX20X3	T20	25	3	0.024	0.24	5906675406190
RT-BIT-TORX25/25	T25	25	20	0.30	3.00	5906675035000
RT-BIT-TORX25X3	T25	25	3	0.024	0.24	5906675072357
RT-BIT-TORX30/25	T30	25	20	0.30	3.00	5906675035017
RT-BIT-TORX30X3	T30	25	3	0.024	0.24	5906675072364
RT-BIT-TORX40/25	T40	25	20	0.30	3.00	5906675035024
RT-BIT-TORX40X3	T40	25	3	0.024	0.24	5906675072371
RT-BIT-TORX50/25	T50	25	20	0.30	3.00	5906675335889
RT-BIT-TORX50X3	T50	25	3	0.024	0.24	5906675406206
RT-BIT-T253040	T25 T30 T40	25	3	0.30	3.00	5906675072418

All products listed in this publication are branded and distributed with RAWLPLUG® or RAWL® trademarks.

RT-TBIT-PH2 Screwdriver bits Phillips 2 with thread M6

NEW

Screwdriver bits Phillips 2 with thread, designed for roof fixings applications.



Product overview

Features and benefits

- Special steel S2 affects the life of the product
- Head tip subjected to additional heat treatment, increasing hardness to 63 HRC
- Precision milled head tip allows for precise fitting into the screw socket
- Anticorrosion coating with a satin finish enhances resistance to rust

Applications

- Installations of flat roof fixings

Packaging



Commercial product data

Index	Size	Length	Working length	Quantity	Box weight	Outer weight	Bar Code
		[mm]	[mm]	[pcs]	kg	kg	
RT-TBIT-PH2/M6	PH2	45	35	10	0.12	1.17	5906675057767

RT-TBIT-TORX25 T25 screwdriver bits with thread M6

NEW



Product overview

Features and benefits

- Special steel S2 affects the life of the product
- Head tip subjected to additional heat treatment, increasing hardness to 63 HRC
- Precision milled head tip allows for precise fitting into the screw socket
- Anticorrosion coating with a satin finish enhances resistance to rust

Applications

- Installations of flat roof fixings

Packaging



Commercial product data

Index	Size	Length	Working length	Quantity	Box weight	Outer weight	Bar Code
		[mm]	[mm]	[pcs]	kg	kg	
RT-TBIT-T25/M6	T25	45	35	10	0.12	1.17	5906675423531

All products listed in this publication are branded and distributed with RAWLPLUG® or RAWL® trademarks.

RT-TBIT-ADAP Adapters with M6 thread

Holder for bits with thread M6



Product overview

Features and benefits

- Stainless steel adapter for increased fault tolerance
- 1/4" (6.35mm) grip allows using most screwdrivers and cordless drills on the market

Applications

- Designed for use with bits for screwing screws and other fastening applications

Packaging



Commercial product data

Index	Length	Quantity	Box weight	Outer weight	Bar Code
	[mm]	[pcs]	kg	kg	
RT-TBIT-ADAP-250	250	1	0.14	2.70	5906675421773
RT-TBIT-ADAP-350	350	1	0.20	3.92	5906675421766
RT-TBIT-ADAP-450	450	1	0.26	5.24	5906675421759
RT-TBIT-ADAP-650	650	1	0.38	7.68	5906675421742
RT-TBIT-ADAP-750	750	1	0.45	9.06	5906675421735

RT-IS Long impact sockets 1/2"

NEW

Impact sockets designed to overcome the high torsional forces



Product overview

Features and benefits

- Special steel S2 with specification 65SiMoCr4 and high hardness extends the life of the product
- Ideally milled slot allows good lateral hold of screws and bolts when screwdriving
- Longer socket enables you to screw in fastenings in hard-to-reach places
- An additional black manganese-phosphorus coating protects the product against corrosion
- 1/2" socket allows you to work with most impact wrenches available on the market

Applications

- Screwdriving in concrete, connecting screws, threaded rods and roof fasteners
- Designed to work with impact wrenches 1/2"

Packaging



Product Commercial Data

Index	Dimensions	External diameter	Length	Quantity	Box weight	Outer weight	Bar Code
	[mm]	[mm]	[mm]	[pcs]	kg	kg	
RT-IS-10-1/2L	10	30	78	1	1.68	10.08	5906675403045
RT-IS-12-1/2L	12	30	78	1	1.94	11.66	5906675403052
RT-IS-13-1/2L	13	30	78	1	1.99	11.95	5906675403069
RT-IS-15-1/2L	15	30	78	1	2.82	16.92	5906675403076
RT-IS-17-1/2L	17	30	78	1	3.10	18.58	5906675403083
RT-IS-19-1/2L	19	30	78	1	3.11	18.65	5906675403090
RT-IS-22-1/2L	22	30	78	1	3.83	22.97	5906675403106



Packaging System

Packaging & labelling

Packaging

Our new packaging systems have been developed in accordance with the latest trends and with a strong focus on eco-friendly design. Boxes are made from high-cellulose content corrugated cardboard, with a water-based varnish used on selected sections. The design incorporates the Rawlplug identity and brand colours within a clean and modern design.

Our new packaging system for resin cartridges can also double up as a product display box, as in the case of our new R-KEM II resin seen here.



Clear communication

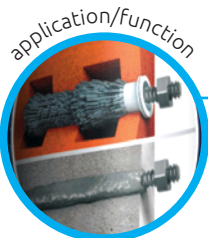

All products listed in this publication are branded and distributed with RAWLPLUG® or RAWL® trademarks.

Packaging & labelling

Innovations

Installation guides

Instructional movie with installation steps, accessed simply by scanning the QR code



Selective varnish
enhanced graphics, reduced absorption of dust and moisture, protection of printing.

One colour print
directly on cardboard

Kraft board type
a high content of cellulose (lower moisture absorption, higher stiffness and durability of cardboard, greater resistance to crushing and deformation)

QR Code
easy scanning thanks to 30% improvement in error correction

Recycling
Information about waste disposal and recycling



Interactive box with QR codes

A QR code (quick response code) is a type of 2D, matrix bar code that is often used to provide access to information through mobile devices.

New colour coded labelling system

Our labels include all technical data necessary for installation. Our mechanical anchors have various material and finish/coating types and these characteristics are denoted by specific label colours (e.g. green for stainless steel).

Each resin type used in our bonded anchor range also has its own colour coded label for resin types (e.g. grey for vinylester resin).

TEMPERATURE	CURING TIME
40°C	18 min
30°C	20 min
20°C	45 min
15°C	1.5 h
10°C	3 h
5°C	4 h
0°C	14 h
-5°C	24 h

Barcode: 5 906673 379920

R-HPTIIA4-10095/15 x50

- Throughbolt
- Bolzenanker
- Coqpen d'ancrage
- Kotva opalozna
- Konkretne parnogruvni anker
- Anker za betony
- Kotva Throughbolt
- Kotva Throughbolt
- Inkarnas kognis
- Alapcsavar
- Anker à vis bridgèr
- Concretes anker
- Expander
- Andaje macho
- Tassello passante
- Sidreni vijak
- Sidreni vijak
- Killa

d1 = 10.0 mm L1 = 95 mm

Barcode: 5 906673 046495



Packaging & labelling

Environmentally friendly philosophy

In our efforts at Rawlplug to care for the environment, we created a packaging system inspired by the latest pro-environmental trends. Paying close attention to the details, a system was developed to minimise waste whilst also

allowing re-use of raw materials. The eco-friendly qualities of our packaging are highlighted by the special logo used on packaging to express our philosophy.

A functional and consistent system

Mechanical Anchors packaging:

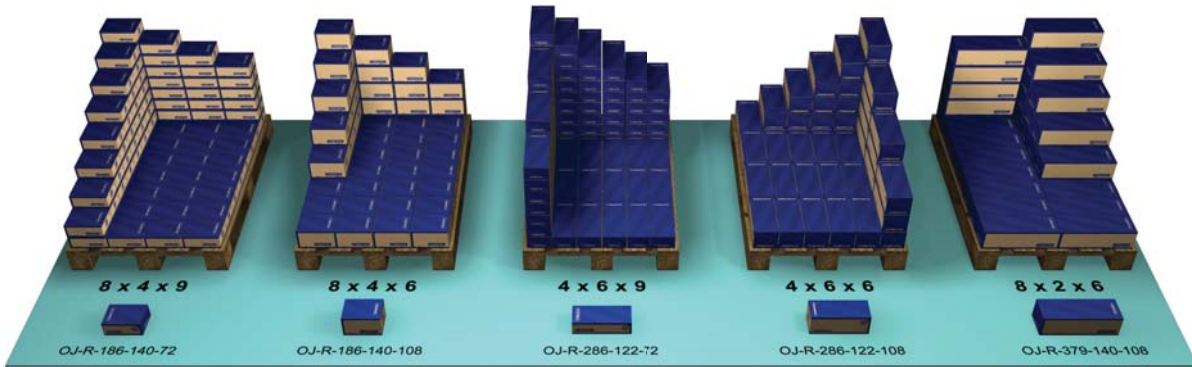

Bonded Anchors packaging:

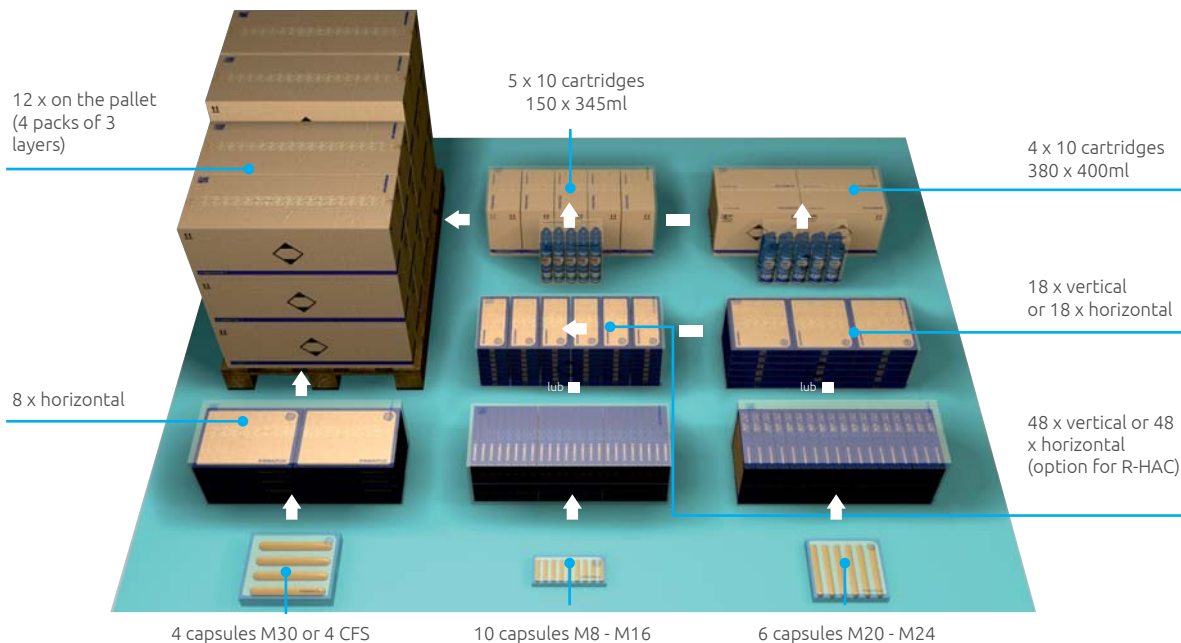



More from Rawlplug

Efficacy in the hardest conditions

We are proud to present innovative fixing from the **Bonded Anchors and Mechanical Anchors** group designed for the heavy loads demanded by industrial construction. Among our products you will find unique solutions to enable you to achieve maximal amounts with any kind of substrate. Knowledge backed-up with experience guarantees the effectiveness of our fixings and the success of your investment.

Durability and versatility

Our wide range of expansion plugs made of synthetic materials and metal, for low and medium loads, have been used for years for both industrial and residential construction. Incredibly durable FF1 from frame fixings group, universal in use 4ALL and UNO Plug, no. 1 on the UK market, are leading products of RAWLPLUG®'s offer in the field of **Lightweight Fixings**, designed with every substrate in mind.

Innovations in Energy Saving construction

As a leading producer of façade insulation fixings we would like to present to you our wide array of products used in energy saving constructions. The Reliability and simplicity of our solutions combined with their ease of installation make them the most popular and desired by professionals. We invite you to familiarize yourselves with our offer for **Façade Insulations Fixings**.

Excellent resistance for high loads

Thanks to our close cooperation with roof covering product producers, and our insight into the needs of investment contractors, our **Roofing Insulations Fixings** are one of the most popular among European roof fixing system producers. We invite cooperation from engineers, architects, and roof works contractors. And encourage you to try out our calculation software "ROOFIX" today.

Safety Certificate

Stepping towards the needs of customers, and increasing the general level of safety in closed spaces, we have created a protection system event of which in the combustion prevents fire and smoke from spreading. We invite you to acquaint with our offer for **Passive Fire Protection Systems**, which hold the European Conformity Assessment.

Guarantee of lasting quality

Thanks to our constant monitoring of the production of assortments from our **Foams, Sealants and Adhesives** range we guarantee the constant and repeatable quality of our products. Their wide range of application possibilities and high efficiency has enabled us to rank among the top 5 of companies in the construction chemistry industry for years.

Maximal weather resistance

Rawlplug® **Fasteners** guarantee reliability of connections and maximal weather resistance. Our products, thanks to the use of appropriate materials and adoption of modern anticorrosion coating, pass even the hardest tests, matching the expectations of the most demanding clients. In our rich offer of screws characterized by extraordinary ease of installation, one may find perfect kind of connection for any kind of material and substrate.

Save time and minimize costs

In our offer of **Direct Fastening Systems** you may find, among others, highly effective pneumatically and gas powered nailers with accessories, compressors and an innovative and ergonomic rebar tier. We invite you to familiarize yourselves with the capabilities of Rawlplug® tools, which can significantly increase the comfort and effectiveness of work at any construction site.

Maximal effect of optimal offer

In order to ease the application and proper use and installation of our products, we supplement the our assortment of fixings with a precisely composed offer of **Power Tool Accessories**. They include, among others, European-made drills of the highest quality, as confirmed with a Sickersafe certificate. We invite you to familiarize yourselves with our offer of accessories for professional installation techniques of the Rawlplug® brand.

Ergonomics for construction and at home

We offer high-quality **Stapling, Tacking and Gluing** tools that are recommended for both professionals and home DIY. Rawlplug's stapling tools are especially intended for construction, finishing works and repairs while our hot-melt adhesive system includes a new line of glue guns and glues for a wide range of applications - all of which are exceptionally easy to use and provide maximum efficiency and a high degree of flexibility for routine work

Unique and exclusive exposition

Rawlplug **POS Essential Offer** it is a unique and complete solution designed for product exposition in building wholesale and retail stores. The POS system is based on easily configurable rack components enhanced with expansive information elements and additional decorations, as well as a combination of individual packages in form of innovative Rawlplug Bag and cutting-edge cardboard boxes.

RAWLPLUG®

Trust & Innovation. Since 1919.



UNITED KINGDOM

Rawlplug Ltd

Skibo Drive
Thornliebank Industrial Estate
Glasgow G46 8JR

Tel: + 44 (0) 141 6387 961

Fax: + 44 (0) 141 6387 397

Email: rawltech@rawlplug.co.uk

Web: www.rawlplug.com

CHINA

Rawlplug Shanghai Trading Co., Ltd.

Unit 801, 233, Rushan Road Shanghai,
P.R. China
Tel: +86 189 1882 8527
Email: henry.yang@rawlplug.com
www.rawlplug.com

CZECH REPUBLIC

Koelner CZ s.r.o

Palackého 1154/76A
702 00 Ostrava-Přivoz
Tel: + 420 596 636A 397
Email: objednavky@rawlplug.cz
Web: www.koelner.cz
Web: www.rawlplug.cz

FRANCE

RAWL France SAS

12-14 Rue Marc Seguin
77290 Mitry-Mory
Tel: + 33 (0) 1 6021 5020
Email: rawl@rawl.fr
Web: www.rawlplug.fr

GERMANY

Koelner Deutschland GmbH

Gmünder Str. 65
73614 Schorndorf
Tel: +49 (0) 7181 977 72-0
Email: info@koelner-befestigung.de
Web: www.rawlplug.com

HUNGARY

Koelner Hungária Kft

Jedlik Ányos út. 34
2330 Dunaharaszti
Tel: + 36 (24) 520 400
Email: info@koelner.hu
Web: www.koelner.hu

INDIA

Rawl India Services Private Limited

Prestige Meridian-1, M.G Road,
Sector -29, Bangalore, Karnataka India,
560001
Tel: +91 9650495828
Email: info@rawlplugindia.com
Web: www.rawlplug.com

IRELAND

Rawlplug Ireland Ltd

Unit 10 Donore Business Park
Donore Road Drogheda
Co Louth A92 C522
Tel: + 353 (0) 41 9844 338
Email: sales@rawlplug.ie
Web: www.rawlplug.ie

LITHUANIA

UAB Koelner Vilnius

Žarijų g. 2
LT-02300, Vilnius
Tel: + 370 (5) 2324 862
Email: koelner@koelner.lt
Web: www.koelner.lt

POLAND

Rawlplug S.A.

ul. Kwidzyńska 6C, 51-416 Wrocław
Tel: +48 (71) 3260 100
Tel: +48 (71) 37 26 111
Email: info@koelnerpolska.pl
Web: www.rawlplug.com

RUSSIA

Koelner Trading KLD LLC

ul. Dzerzhinskogo 219
236034 Kaliningrad
Tel: + 7 (4012) 65 85 75
Email: info@koelner-trading.ru
Web: www.koelner-trading.ru

SINGAPORE

Rawlplug Singapore Pte. Ltd.

Blk 302, #04-11, 25B Loyang Crescent
Loyang Offshore Supply Base
Singapore 506817
Tel: + 65 9078 5220
Email: jacek.nowicki@rawlplug.com.sg
Web: www.rawlplug.com

SLOVAKIA

Koelner Slovakia s.r.o.

Dlhá 95
010 09 Žilina
Tel: + 421 415 003 900
Email: objednavky@rawlplug.sk
Web: www.koelner.sk
Web: www.rawlplug.sk

SWEDEN

Rawl Scandinavia AB

Baumangatan 4
593 32 Västervik
Tel: + 46 (0) 4903 0660
Email: info@rawlplug.se
Web: www.rawlplug.se

UKRAINE

Koelner Ukraine LLC

Lvivska Bichna, 6
Sokilnyky
Pustomyty Dstr., Lviv Reg. 81130
Tel: + 380 (82) 2440 744
Email: koelner@koelner.ua
Web: www.koelner.ua

UNITED ARAB EMIRATES

Rawlplug Middle East FZE

P.O. Box 261024 Dubai, UAE
Warehouse No. RA08BC01
Tel: + 971 (4) 8839 501
Email: dubai@rawlplug.co.uk
Web: www.rawl.ae

UNITED STATES OF AMERICA

Rawlplug Inc.

Corporation Trust Center
1209 Orange St Wilmington,
New Castle, DE 19801,
Tel: + 1 302 658 7581
www.rawlplug.us

